

USE AND MAINTENANCE MANUAL



Ed. 05/2024 - ver. 006

PLANETARY MIXER 7 It

FOREWORD

- *This manual is meant to provide **Customers** with information about this mixer and its specifications and the necessary operating and maintenance instructions in order to ensure mixer performance and longevity.*
- *This manual is to be used by qualified and skilled operators with thorough knowledge of mixer use and maintenance*

CONTENTS

CHAP. 1 - INFORMATION ON THE MIXER	pg. 4
1.1 - GENERAL WARNINGS	
1.2 - SAFETY DEVICES INSTALLED ON THE MIXER	
1.2.1 - mechanical safety protections	
1.2.2 - electrical safety protections	
1.3 - DESCRIPTION OF THE MIXER	
1.3.1 - General description	
1.3.2 - Manufacturing features	
1.3.3 - Mixer components	
CHAP. 2 - TECHNICAL SPECIFICATIONS	pg. 6
2.1 - OVERALL DIMENSIONS, WEIGHT, FEATURES...	
CHAP. 3 - RECEIVING THE MIXER	pg. 7
3.1 - DESPATCH OF THE MIXER	
3.2 - PACKAGE CHECK UPON RECEIPT	
3.3 - DISPOSING OF PACKAGING	
CHAP. 4 - INSTALLATION	pg. 8
4.1 - MIXER SET-UP	
4.2 - ELECTRICAL CONNECTION SINGLE-PHASE	
4.3 - WIRING DIAGRAM	
4.3.1 - mixer wiring diagram	
4.4 - FUNCTIONAL CHECK	
CHAP. 5 - USE OF THE MIXER	pg. 9
5.1 - CONTROLS	
5.2 - LOADING THE PRODUCT	
CHAP. 6 - REGULAR CLEANING	pg. 10
6.1 - GENERAL GUIDELINES	
6.2 - HOW TO CLEAN THE MIXER	
6.2.1 - cleaning utensils and bowl	
6.2.2 - regular cleaning	
CHAP. 7 - MAINTENANCE	pg. 11
7.1 - GENERAL GUIDELINES	
7.2 - POWER SUPPLY CABLE	
7.3 - UTENSILS	
CHAP. 8 - SCRAPPING	pg. 12
8.1 - PUTTING THE MIXER OUT OF SERVICE	
8.2 - SCRAPPING	
8.3 - WEEE Waste of Electric and Electronic Equipment	

CHAP. 1 - INFORMATION ON THE MIXER

1.1 - GENERAL WARNINGS

- The machine must be operated only by highly qualified personnel who are fully aware of and familiar with the safety measures described in this manual.
- In the event of personnel turnover, training is to be provided in advance.
- Before starting cleaning and maintenance operations, disconnect the plug from the power supply socket.
- To perform cleaning and maintenance, assess the residual risks carefully (as safety protections are removed).
- Always remain concentrated when cleaning and servicing the machine.
- Check the power supply cable regularly. A damaged or worn cable is an electrical hazard.
- If the machine malfunctions, it is recommended not to use it and do not try to repair it; please call the "Service Centre", contact details are provided at the back of this manual.
- Do not use the machine for processing frozen products, bones or non food products.
- Do not introduce hands or objects into the bowl with the mixer working .
- The manufacturer shall not be liable for damage to things or injury to persons in the event:
 - ⇒ The machine or the safety devices and protections have been tampered with by unauthorised personnel;
 - ⇒ Non original spare parts are installed;
 - ⇒ The instructions provided in this manual **are not followed scrupulously**;
 - ⇒ The machine surface is cleaned with unsuitable cleaning products

1.2 - SAFETY DEVICES AND PROTECTIONS INSTALLED ON THE MACHINE

1.2.1 - mechanical safety protections

Regarding mechanical safety protections the machine has been manufactured in compliance with the EU directive **EEC 98/37**.

1.2.2 - electrical safety protections

Regarding electrical safety protections the machine has been manufactured in compliance with the EU directives **EEC 73/23, 89/336**.

The mixer is fitted with a safety microswitch which automatically stops the machine when the tilt-head is raised (*refer to FIG. n°1*);

Although the machine is fitted with both electrical and mechanical protections complying to legislation, there are however other hazards considered **RESIDUAL RISKS (EEC 89/392 clause 1.7.2)** which cannot be eliminated completely. These hazards are listed in this manual under **WARNINGS**. These hazards refer to possible injury when cleaning the mixer and utensils.

1.3 - DESCRIPTION OF THE MACHINE

1.3.1 - General description

This planetary mixer has been designed and developed by our company for the purpose of mixing, blending, whipping, beating food products such as eggs, flour, cream and food products that are neither hard nor very thick and ensures:

- the highest degree of safety during use, cleaning and maintenance;

- the highest standard of hygiene due to a careful selection of materials which come into contact with food products, elimination of sharp edges in the machine structure that come into contact with the food product, facilitating and ensuring perfect cleaning, as well as facilitating machine disassembly and part removal;
- maximum performance and efficiency;
- robust and stable components;
- reduced noise emission;
- practical and easy to move .

1.3.2 - Manufacturing features

The planetary mixer is manufactured in:

- Main mixer block - paint finish aluminium;
- Easy to remove stainless bowl;
- Stainless steel and aluminium utensils;
- Chrome plated steel protection grille.

1.3.3 - mixer components

FIG. n.1 - Main mixer parts



Mod. Plus

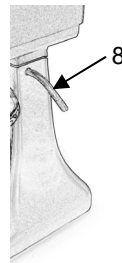

LEGEND:

- 1 Tilt-head
- 2 Protection bowl
- 3 Beater
- 4 Bowl
- 5 Base
- 6 Flat beater
- 7 Dough hook
- 8 Tilt-head lock
- 9 ON / OFF pushbuttons 0/I
- 10 Speed change

CHAP. 2 - TECHNICAL SPECIFICATIONS

2.1 - OVERALL DIMENSIONS, WEIGHT, FEATURES ...

FIG. n.2 - Overall dimensions

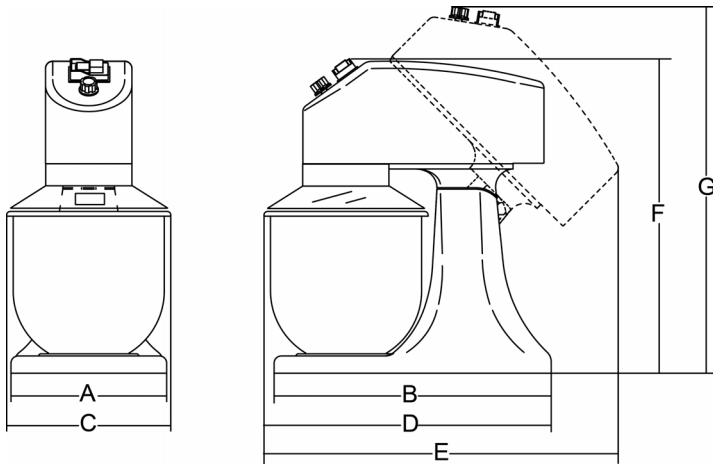

Model	u.m.	7 lt.	7 lt. Plus
A x B	mm	220x285	220x285
C x D x F	mm	240x410x437	240x410x437
C x E x G	mm	240x450x510	240x450x510
Bowl capacity	l.	7	7
Small soft doughs Max flour quantity	kg	1	1
Whip revolutions	g/1'	75 - 660	75 - 660
Motor	W	280	350
Power supply		230V/50Hz	230V/50Hz
Net weight	kg	14,7	15
Noise level	dB	≤ 70	≤ 70

WARNING: Machine electrical specifications are indicated on the rating plate affixed to the rear of the mixer; before connecting to power supply, please read § 4.2 wiring.

CHAP. 3 - RECEIVING THE MIXER

3.1 - DESPATCH OF THE MIXER (see FIG. n. 3)

The mixer is accurately packed and then despatched from our warehouse. Packaging includes:

- a) a solid cardboard box;
- b) the mixer;
- c) this manual;
- d) CE certificate of conformity.

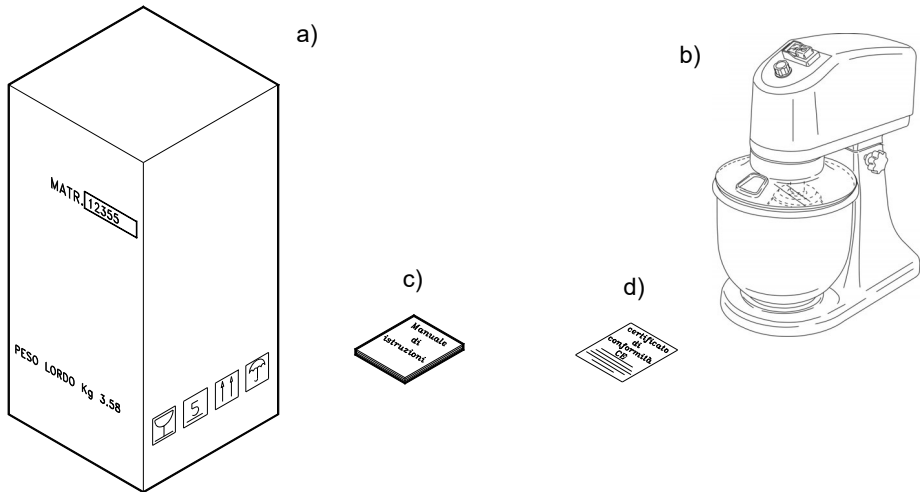

FIG. n. 3 - Description of packaging

3.2 - PACKAGE CHECK UPON RECEIPT

If the package shows signs of damage caused during transport, the carrier must be informed immediately; moreover a detailed report on the extent of the damage caused to the machine must be notified to the carrier within three days from the delivery date on the shipping documents. Do not overturn the package!! When the package is transported, make sure it is lifted by the 4 corners (parallel to the ground).

3.3 - DISPOSING OF PACKAGING

The components of the packaging (cardboard, plastic straps) are urban solid waste which can be easily disposed of.

If the mixer is to be installed in countries where specific regulations are in force, packaging must be disposed of in compliance with such regulations.

CHAP. 4 - INSTALLATION

4.1 - MIXER SET-UP

The mixer must be installed on a suitable and adequate size countertop refer to specifications (*refer to Chap. 2*) and which must be perfectly level, dry, smooth, robust and stable. Moreover, the mixer must be installed in a room with max. 75% no saline humidity at a temperature between +5°C and +35°C; and however in a location and workplace that does not provoke malfunctions or faults in the mixer.

4.2 - ELECTRICAL CONNECTION SINGLE-PHASE

The mixer is supplied with a power supply cable having a 3x1.5 mm² section; 1.5 m length and a “SHUKO” plug.

Connect the machine to the 230 Volt 50 Hz mains power supply by interposing a 10A, $\Delta I = 0.03A$ differential thermomagnetic switch. Check correct machine earthing.

Now check that the specifications on the rating plate-serial number (*FIG. n. 4*) correspond to the specifications provided in the consignment and delivery note.

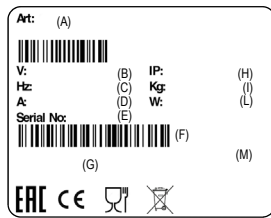

LEGEND

- (A) = Product code and name
- (B) = Power supply
- (C) = Motor frequency
- (D) = Amperage
- (E) = Serial number
- (F) = Barcode
- (G) = Manufacturer
- (H) = International Protection
- (I) = Weight
- (L) = Power
- (M) = Origin

FIG. n. 4 - Rating plate—serial number

4.3 - WIRING DIAGRAM

4.3.1 - Mixer wiring diagram

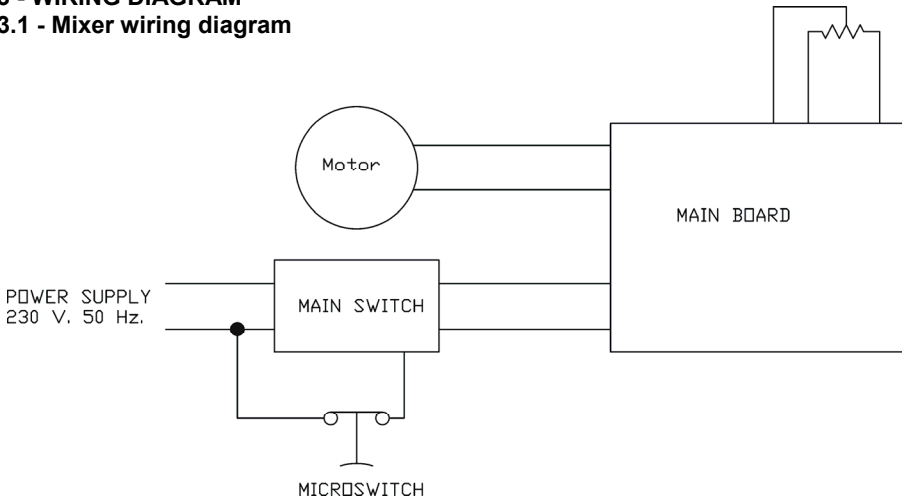

FIG. n. 5 - Wiring diagram

4.4 - FUNCTIONAL CHECK (FIG. n. 1)

Before using the mixer check that:

- The mixing bowl (FIG. n.1 - ref. 4) is correctly positioned;
- The mixing utensil (FIG. n.1 - ref. 3) is correctly fitted;
- There are no other accessories or utensils in the mixing bowl (FIG. n.1 - ref. 4);
- The protection grille (FIG. n.1 - ref. 2) offers adequate protection in the workplace

Proceed as follows:

1. Start the mixer by pressing pushbutton "1", and then press pushbutton "0" to stop the mixer;
2. Check utensil rotation and change speed utilising the speed change (FIG. n. 6 - ref. 1);
3. Test the safety microswitch on the tilt-head, raising the tilt-head (FIG. n.1 - ref. 1) the mixer should stop automatically.

CHAP. 5 - USE OF THE MIXER

5.1 - CONTROLS

Mixer controls are located in the position illustrated in the following figure.

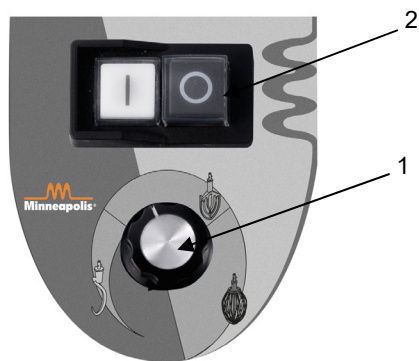

1 - speed change
2 - pushbuttons 0/1

FIG. n°6 - Controls

5.2 - LOADING THE FOOD PRODUCT

The food product must be loaded into the bowl with the machine off. When loading take care with the utensil to avoid injury to hands or damage.

N.B.: Do not load with solids!

Before adding products to the mixture when processing food products, always **TURN THE MACHINE OFF.**

Proceed as follows:

1. Raise the tilt-head;
2. (**WARNING**) when loading the bowl with the food product take care not to injure hands with the utensil;
3. Make sure the bowl is correctly positioned;
4. Lower the tilt-head;
5. To prevent accidents, position yourself correctly; your body must be perpendicular to the countertop (refer to FIG. n. 7): do not force any of the machine components with

your hands or block or touch moving utensils. **Do lean against the mixer to prevent your body from coming into direct contact with it;**

6. To start the mixer press pushbutton “1” and if required increase speed by turning the speed control knob.
7. Once terminated mixing turn the speed control knob to “0” and stop the mixer by pushing the stop pushbutton marked “0”;
8. Raise the tilt-head and remove the bowl with care.

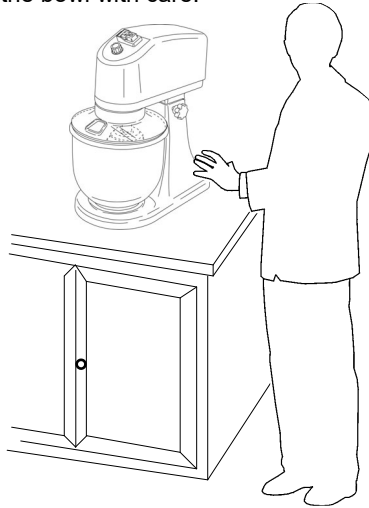

FIG. N. 7 - Correct posture

CHAP. 6 - REGULAR CLEANING

6.1 - GENERAL GUIDELINES

- The machine must be cleaned at least once a day. If necessary, clean when required during the day.
- All the machine parts that come into contact directly or indirectly with the food product must be cleaned thoroughly.
- Never clean the machine with pressurised water, water jets but with plain water and neutral food grade detergents; do not use brushes or other tools or anything that could damage the mixer surface.

Before cleaning the mixer always:

- a) Remove mixer plug from power socket in this way the mixer is isolated from the mains power supply;
- b) Turn the speed control knob to “0”.

6.2 - HOW TO CLEAN THE MACHINE

6.2.1 - cleaning utensils and bowl

To clean the utensil hub proceed as follows:

- a) Remove mixing bowl from mixer;
- b) Remove tool **ALWAYS TAKE CARE** when handling mixing tools to avoid injury.

Once the tools have been removed, to clean use warm water and a neutral food grade detergent. If the bowl and tool hub remain unused for more than two hours wash these parts with hot water and neutral food grade detergents. These parts however should be

washed at least once a day.

WARNING! Never wash any of the mixer components or utensils in the dishwasher.



FIG. n. 8 - Mixer parts and components

6.2.2 - regular cleaning

NB.: Remove mixer plug from power socket

Use a damp cloth and neutral food grade detergent to clean mixer block, remember to rinse the cloth with warm frequently when cleaning .

After cleaning dry thoroughly.

CHAP. 7 - MAINTENANCE

7.1 - GENERAL GUIDELINES

Before performing any maintenance operation, **remove the plug from the power socket to isolate it from the mains power supply.**

7.2 - POWER SUPPLY CABLE

Periodically check for wear in the power supply cable. If the power supply cable shows signs of wear or damage contact the “SERVICE CENTRE” for a replacement.

7.3 - UTENSILS

If the utensils are faulty contact the “SERVICE CENTRE” for assistance.

CHAP. 8 - SCRAPPING

8.1 - PUTTING THE MACHINE OUT OF SERVICE

If for some reason, you decide to put the machine out of service, make sure nobody can use it: disconnect it from the mains and eliminate electrical connections.

8.2 - SCRAPPING

When the machine is out of service, it can be disposed of. To scrap the machine contact your local Specialised Waste Treatment Centre, separate mixer components (**refer to chap. 1 par. 3.2**).

8.3 - WEEE Waste of Electric and Electronic Equipment



This symbol, crossed out wheelie bin, on the product or on its packaging indicates that this product must not be disposed of with your other household waste.

Separate waste collection of this appliance is organised and managed by the manufacturer. It is the user's responsibility to contact the manufacturer and follow the waste treatment system the manufacturer has adopted for separate waste collection.

The separate collection and recycling of your waste equipment at the time of disposal will help to conserve natural resources and ensure that it is recycled in a manner that protects human health and the environment.

**SERVICE CENTRE
AUTHORISED DEALER**