

600L Refrigerators and Freezers

HW600

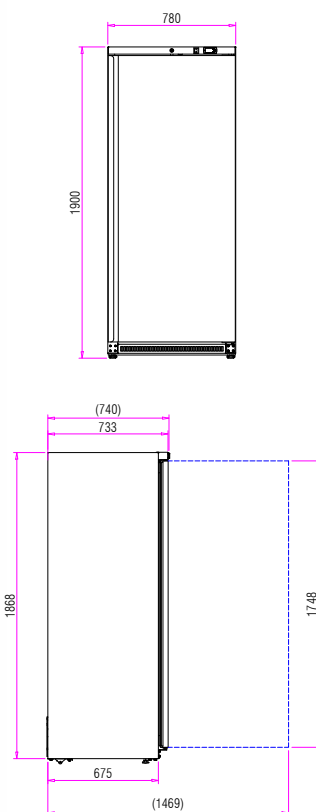

LS600



FEATURES

White laminated (W) or stainless steel exterior (S)

White aluminium interior

Reversible door

Lock fitted as standard

Refrigerator - 4 adjustable shelves
Freezer - 5 fixed shelves

Rollers to rear, adjustable feet to the front

Replaceable door gasket

TECHNICAL SPECIFICATIONS

	Refrigerator	Freezer
Controller:	Dixell controller	
Cooling:	Ventilated	Static
Defrost:	Automatic	Manual
Refrigerant:	R290	R290
Climate Class:	4	4
Temperature Range:	+2°C ~ +8°C	-18°C ~ -22°C
Power Supply:	13amp	13amp

MODEL	TEMPERATURE RANGE	GROSS CAPACITY	EXT. DIMENSIONS (H x W x D mm)	ENERGY RATING	POWER CONSUMPTION	KWH /ANNUM	DECIBELS	WEIGHT (kg)	RRP
HW600	+2°C ~ +8°C	600L	1900 x 780 x 740	D	267W	974	48dBA	110	
HS600	+2°C ~ +8°C	600L	1900 x 780 x 740	D	267W	974	48dBA	110	
LW600	-18°C ~ -22°C	600L	1900 x 780 x 740	-	350W	-	48dBA	120	
LS600	-18°C ~ -22°C	600L	1900 x 780 x 740	-	350W	-	48dBA	120	

