



VEGETABLE PREPARATION MACHINE CA-601

Commercial Vegetable Processor with an hourly output of up to 1000 Kg. with automatic hopper.



FEATURES AND BENEFITS

- ✓ Stainless steel construction and high quality material, all suitable for contact with food.
- ✓ New production technology that gives a uniform, high-quality cutting result.
- ✓ The large range of high quality discs and grids allows the operator to obtain over 70 different styles of product.
- ✓ Ergonomic design that allows to cut the product in just one movement.
- ✓ Lateral product ejection, reducing the amount of counter space required, whilst also minimising product splashing.
- ✓ This directs the product avoiding splashing.
- ✓ Electronic, user-friendly control board.
- ✓ Easily removable lever and lid for cleaning purposes.
- ✓ NSF-International certified appliance (complying with Hygiene, Cleaning and Food Material regulations).

INCLUDES

- ✓ 2 speed motor block.
- ✓ Automatic hopper.

SALES DESCRIPTION

2 speed motor block and large production automatic hopper.

- ✓ New production technology that gives a uniform, high-quality cutting result.
- ✓ Ergonomic design.
- ✓ Lateral product eject requires less space on the worktop and directs the product avoiding splashing.
- ✓ Easily removable hopper and lid for cleaning purpose.
- ✓ NSF listed: guaranteed hygiene and safety.
- ✓ 3-phase only.
- ✓ Discs are not included*.



www.sammic.co.uk

Food Service Equipment Manufacturer

Unit 2, Trevanah Road
Troon Industrial Park
LE4 9LS - Leicester

uksales@sammic.com
Tel.: +44 0116 246 1900



Project

Date

Item

Qty

Approved

DYNAMIC PREPARATION
COMMERCIAL VEGETABLE PREPARATION MACHINES

product sheet
updated 06/03/2018



VEGETABLE PREPARATION MACHINE CA-601

Commercial Vegetable Processor with an hourly output of up to 1000 Kg. with automatic hopper.



SPECIFICATIONS

- Hourly production: 500 Kg - 1000 Kg
- Inlet opening: 273 cm²
- Disc diameter: 205 mm
- Total loading: 750 W
- Motor speed: 365 rpm / 730 rpm
- External dimensions (WxDxH)
- Width: 431 mm
- Depth: 418 mm
- Height: 767 mm
- Net weight: 26 Kg
- Noise level (1m.): <70 dB(A)
- Background noise: 32 dB(A)

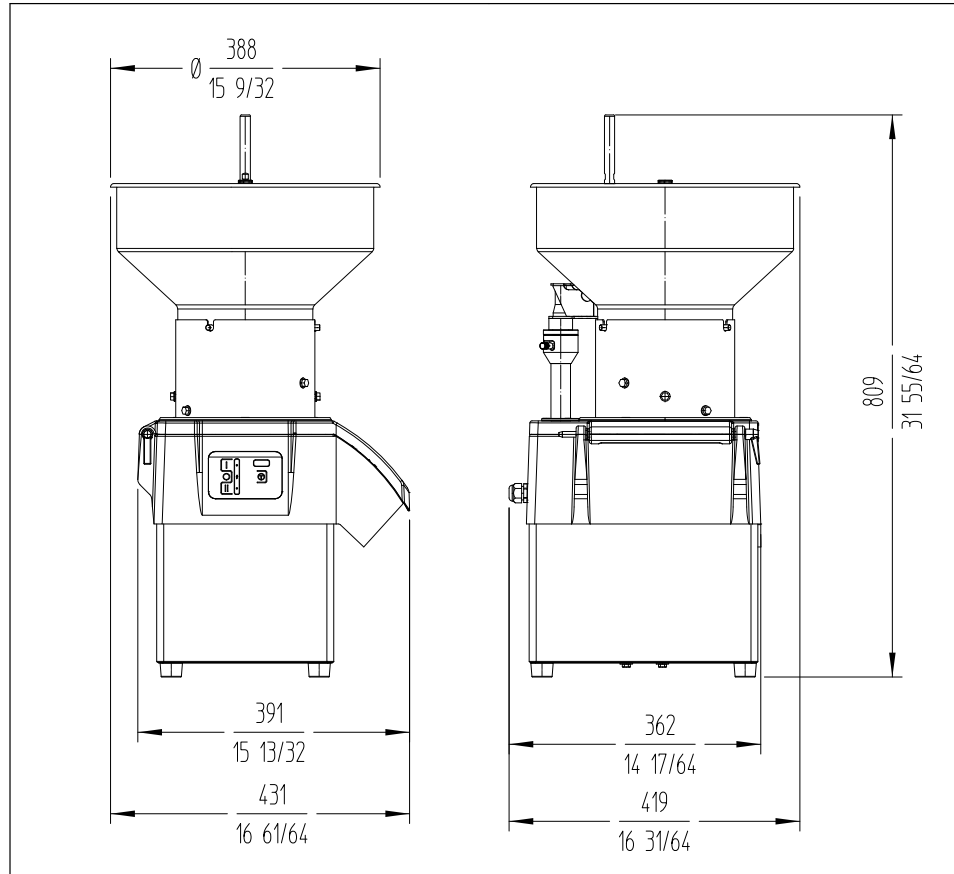

AVAILABLE MODELS

1050062 Vegetable preparation machine CA-601 2V 400/50/3N

* Ask for special versions availability

ACCESSORIES

- FC Slicing Disc
- FCC Curved Slicing Discs
- FCO Rippled Slicing Discs
- FFC Chipping Grids
- FMC Dicing Grids
- FCE Julienne Discs
- FR Shredding & Grating Discs
- Long vegetable attachment
- Universal hopper
- Disc and Grid Holder Device
- Grid Cleaning Kit

DYNAMIC PREPARATION
COMMERCIAL VEGETABLE PREPARATION MACHINES



www.sammic.co.uk

Food Service Equipment Manufacturer

Unit 2, Trevanah Road
Troon Industrial Park
LE4 9LS - Leicester

uksales@sammic.com
Tel.: +44 0116 246 1900



Project

Date

Item

Qty

Approved

product sheet
updated 06/03/2018