



GLASSWASHER X-41BD 230/50/1 DD (BUILT-IN WATER SOFTENER AND DRAIN PUMP)

400x400mm racks. Max. loading height: 280mm

P/N 1302034



FEATURES AND BENEFITS

- ✓ For washing glasses, cups, cutlery and small plates.
- ✓ 3 wash cycles with final cold rinse.
- ✓ Manufactured from catering grade AISI 304 2B stainless steel and incorporating top quality components.
- ✓ Double skinned door with high efficiency seal, ensuring thermal and acoustic insulation. Magnetic door micro-switch.
- ✓ Removable stainless steel rack holders ensure even distribution of wash water without dead zones. Precision positioned water jets guarantee optimum washing result for even the most stubbornly stained glasses. Easy to assemble, boltless rinse spray arms.
- ✓ Rinsing dispensers without screws, easy assembly and simple and clean look.
- ✓ A double filter system provides effective wash pump protection that is easily removed (for maintenance and cleaning) and replaced, without tools.
- ✓ Completely rounded, stainless steel wire rack support and guide.
- ✓ Automatic detergent and rinse aid dosing equipment.
- ✓ Electronic control panel with anti-moisture seal.
- ✓ Adjustable washing tank and boiler temperature and security in the boiler.
- ✓ Rinse boiler temperature adjustment and a thermal cycle delay option, guaranteeing a minimum final rinse temperature of 85°C for each and every rinse cycle.
- ✓ Sammic ware washers are designed for easy and fast on-site maintenance.

SALES DESCRIPTION

Top + bottom wash arms. 3 wash cycles. Cold rinse facility. Option of built-in water softener.

- ✓ Best performance.
- ✓ Optimal washing results.
- ✓ Sturdy and reliable.
- ✓ Stainless steel, sturdy and resistant washing arms. Don't get damaged because of chemical corrosion.
- ✓ 2.5 kW boiler: optimal recovery time.
- ✓ Full optional list.

INCLUDES

- ✓ Built-in water softener. equipment.
- ✓ Drain pump and non-return valve. ✓ 1 open basket.
- ✓ Rinse aid doser. ✓ 1 mixed basket.
- ✓ Variable detergent dosing ✓ 1 small cutlery basket.



www.sammic.co.uk

Food Service Equipment Manufacturer

Unit 2, Trevanth Road
Troon Industrial Park
LE4 9LS - Leicester

uksales@sammic.com
Tel.: +44 0116 246 1900



Project

Date

Item

Qty

Approved

WARE WASHING
COMMERCIAL GLASSWASHERS

product sheet
updated 07/05/2018



GLASSWASHER X-41BD 230/50/1 DD (BUILT-IN WATER SOFTENER AND DRAIN PUMP)

400x400mm racks. Max. loading height: 280mm

P/N 1302034

SPECIFICATIONS

- Basket dimensions: 400 mm x 400 mm
- Maximum glass height: 280 mm
- Cycle duration: 90 " / 120 " / 210 "
- Production baskets/hour: 40 / 30 / 17
- Boiler capacity: 4.5 l
- Wash tank capacity: 16 l
- Water consumption/cycle: 2.2 l
- Electrical supply: 230 V / 50 Hz / 1 ~ (12.5 A)
- Plug: -

Loading

- ✓ __ Pump: 240 W / 0.33 Hp
- ✓ Tank: 1500 W
- ✓ Boiler: 2500 W
- ✓ Total loading: 2740 W
- ✓

External dimensions (WxDxH)

- ✓ Width: 470 mm
 - ✓ Depth: 535 mm
 - ✓ Height: 710 mm
- Net weight: 42.2 Kg

Crated dimensions

- 525 x 615 x 820 mm
Gross weight: 47.4 Kg.

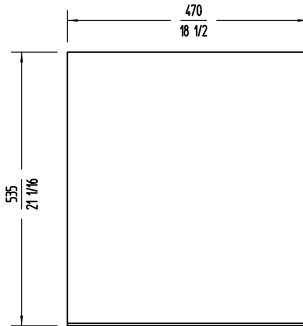
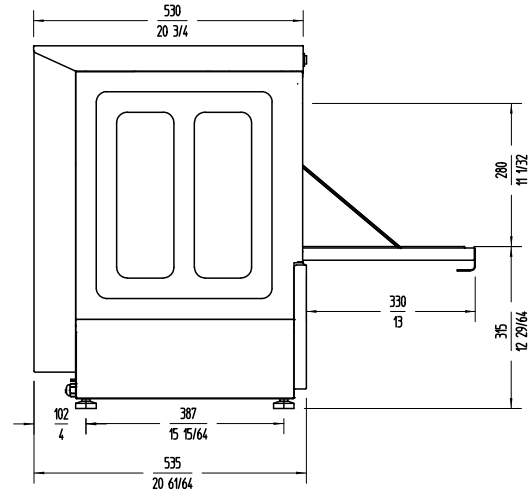
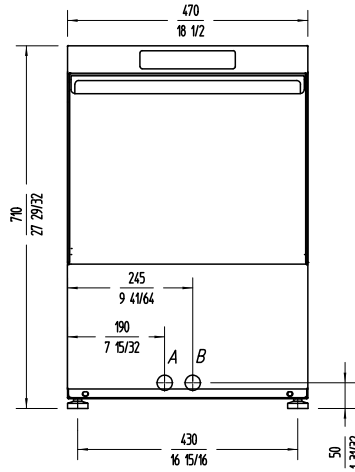

ACCESSORIES

- Stands for glass- and dishwashers
- Dosing equipments
- Manual water softeners
- Automatic water softeners
- 400X400 mm. baskets
- Inserts, supplements & similar
- High Feet Kit



WARE WASHING
COMMERCIAL GLASSWASHERS



www.sammic.co.uk

Food Service Equipment Manufacturer

Unit 2, Trevanah Road
Troon Industrial Park
LE4 9LS - Leicester

uksales@sammic.com
Tel.: +44 0116 246 1900



Project

Date

Item

Qty

Approved

product sheet
updated 07/05/2018