



MODEL:

WS2-KVS

BASIX

manufactured by **MECHLINE**

BaSix WS2 Hand Wash Station. Knee-operated, Hands-Free mechanical operation. Includes knee-valve, fixed spout, M-MX91 manual mixer, water hose & tap hole stopper

Dimensions: O/D: 305 x 270 x 140 Bowl: 240 x 135 deep

Manufacturer: Mechline Developments Limited.

Brand: BaSix.

Model Range: WS2

Controls: Hands-Free.

Tap Type: Knee-operated.

FEATURES & BENEFITS

- Range of hygienic hand washing solutions.
- Helps operations meet their requirement to provide hand-washing stations on site.
- Good and safe habits are more easily followed and enforced.

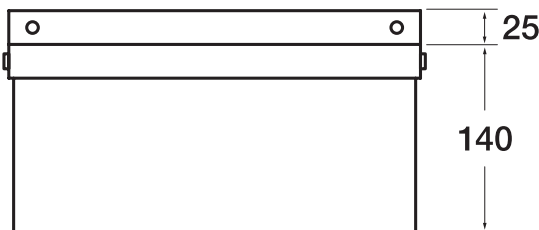
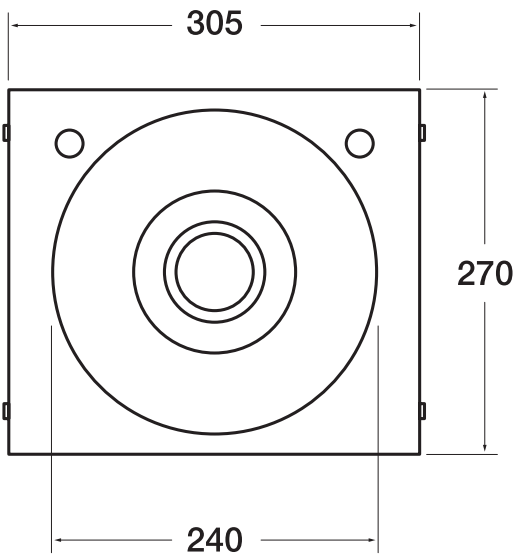

MAINTENANCE & CLEANING

Cleaning chrome: Do not use abrasive, chlorine or acid-based cleaning products. Avoid contact with concentrated bleach.

Clean with soapy water using a cloth or sponge.

Dimensions are in millimeters. If a CAD file is required please visit www.mechline.com.



MECHLINE

MECHLINE DEVELOPMENTS LIMITED

Tel: +44 (0)1908 261511 | Email: info@mechline.com | Web: www.mechline.com