

DOMINATOR STOCKPOT STOVE

G1478



DESCRIPTION

Stockpot stove with powerful double ring concentric gas burner operated by front mounted control knob.

Vitreous enamelled cast iron hob with removable cast iron pan support.

Stainless steel panelling and robust heavy gauge tubular legs with adjustable feet.

FEATURES and BENEFITS

- Vitreous enamelled cast iron hob
 - Robust and hard wearing
- Removable cast iron pan support
 - Easy to remove and clean
- Powerful double ring concentric burner
 - Flexible control from fast boil to gentle simmer
- Heavy gauge tubular legs
 - Supports up to 40kg of weight
- Single control knob operation
 - Simple to use

OPTIONAL ACCESSORIES

VENTILATION

Adequate ventilation, whether natural or mechanical, must be provided to supply sufficient fresh air for combustion and to allow easy removal of such products that may present risk to health. Recommendations for ventilation of appliances are given in BS5440:2 and HVCA specification DW/172. For multiple installations, requirements for individual appliances should be added together. Installation of any such system must be completed in accordance with local and/or national regulations that apply at time of commissioning.

SITING

Install stockpot stove on a level, fireproof surface in a well lit, draught free position. If floor is made of a combustible material, local fire requirements must be checked to ensure compliance. A clearance of 150mm should be observed between appliance rear and any combustible wall. Minimum vertical clearance of 1200mm should be maintained above top edge of the stockpot stove. No direct connection of flue should be made to any mechanical extraction system or to the outside air.





DOMINATOR STOCKPOT STOVE

G1478

MODEL DIMENSIONS (in mm)

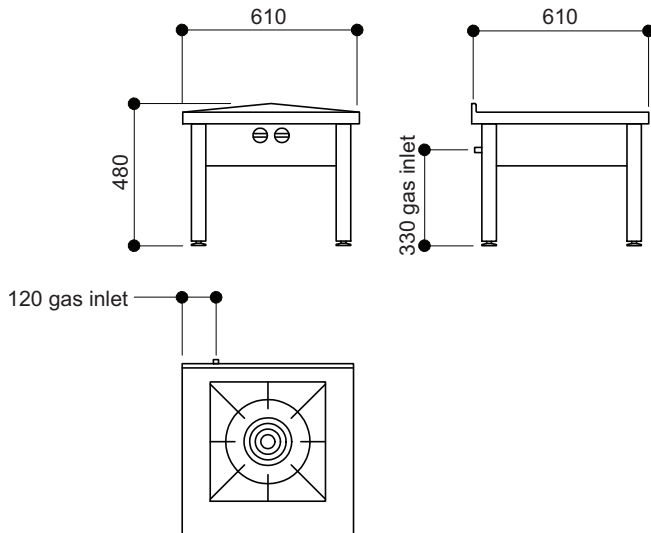

SPECIFICATION DETAILS

* ratings are gross values

G1478

Total rating - Nat (kW - btu/hr)	16.1 / 55,000
Total rating - Prop (kW - btu/hr)	16.1 / 55,000
Inlet pressure (nat/prop. mbar)	20 / 37
Flow rate - Nat. (m ³ /hr)	1.55
Flow rate - Prop. (kg/hr)	1.14
Operating pressure (nat/prop. mbar)	15 / 37
Gas inlet (nat/prop.)	1/2" BSP
Weight (kg)	40
Packed weight (kg)	45

