

FEATURE		TECHNICAL DATA	MACHINE DESCRIPTION
Model	3FT Ecochill Bottle Cooler (RV)		<p>Fully adjustable shelving</p> <p>LED illuminated maximised display area</p> <p>Lighting can be switched off independently</p> <p>Adjustable front feet</p> <p>Swing hinged door or sliding doors</p> <p>Low energy 12V DC evaporator fan</p> <p>Doors and cabinet both available in brushed stainless steel</p> <p>Convert the cabinet to a wine fridge using wine racks available as spares</p> <p>Adjustable digital thermostat to allow accurate and efficient temperature control</p> <p>Automatic Defrost</p>
Packed size Width	1160mm		
Packed size Depth	620mm		
Packed size Height	1040mm		
Capacity	207 Litres		
Width	910mm		
Depth	500mm Swing(excl hndl)/520mm Slide		
Height	900mm		
Installation Space Required	915mmW x 545mmD x 925mmH		
Weight (Packed)	82kg		
Weight (Unpacked without product)	69kg		
Temperature Range	+2°C to +10°C		
Power Rating	140 Watts		
Rated Energy Consumption (Swing)	1.3 kWh / 24 hours		
Rated Energy Consumption (Slide)	1.56 kWh / 24 hours		
Power supply	230V / 50Hz		
Fuse	13 Amps		
Cooling system	Fan assisted		
Refrigerant type	R600a		
Refrigerant charge weight	63 grammes		
Door illumination	LED		
Door Lock	Optional		
Clearance to underside of work surface	25mm		
Climate Class	N		
Operating Pressure - High	0.5 Mpa		
Operating Pressure - Low	0.0 Mpa		
Bottle Capacity (330ml)	174		
Can Capacity (330ml)	270		
ACCESSORIES			
Wine Shelf kit (RV005133)			
Swing Door Lock (01002982)			

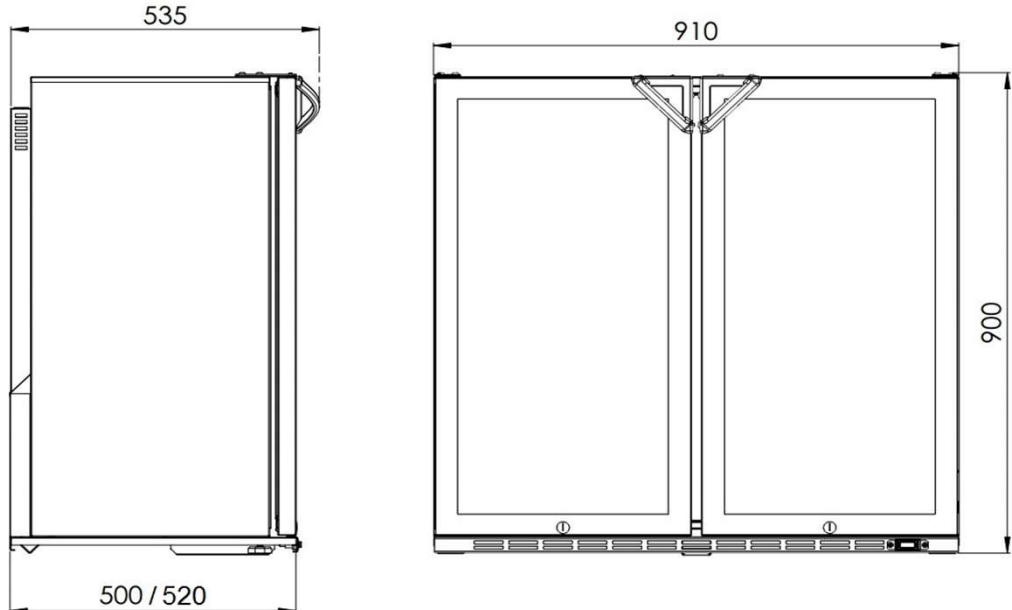

This information is intended as a guide only and reflects the current specification at the time of print. For additional information on this product please contact the Autonumis Sales Department on 01666 502641 or email: info@autonumis.co.uk