



PS-12 MEAT MINCER

Hourly output: up to 100 Kg.



DYNAMIC PREPARATION
COMMERCIAL MEAT MINCERS



FEATURES AND BENEFITS

Ideal for foodservice, communities and food retailers.

- ✓ Body and hopper in stainless steel.
- ✓ Mincing head blockage that ensures a perfect cut.
- ✓ Sturdy and ventilated motor.

INCLUDES

- ✓ Enterprise system, aluminium cutting unit.
- ✓ Ø 6mm. mesh plate.

SALES DESCRIPTION

Motor unit and cutting unit in aluminium.

System: Enterprise.

1 knife and a Ø 6 mm. mesh plate included.



www.sammic.co.uk

Food Service Equipment Manufacturer

Unit 2, Trevanth Road
Troon Industrial Park
LE4 9LS - Leicester

uksales@sammic.com
Tel.: +44 0116 246 1900



Project	Date
Item	Qty
Approved	

product sheet
updated 06/03/2018



PS-12 MEAT MINCER

Hourly output: up to 100 Kg.



SPECIFICATIONS

Production /hour (max): 100 Kg
Plate diameter: 70 mm
Inlet mouth diameter (1) : 45 mm
Electrical supply: 230 V / 1 ~
Total loading: 440 W

External dimensions (WxDxH)

✓ Width: 227 mm
✓ Depth: 470 mm
✓ Height: 410 mm
Net weight: 17.3 Kg
Noise level (1m.): <70 dB(A)
Background noise: 32 dB(A)
IP Protection grade:21

Crated dimensions

340 x 480 x 340 mm
Gross weight: 18.9 Kg.

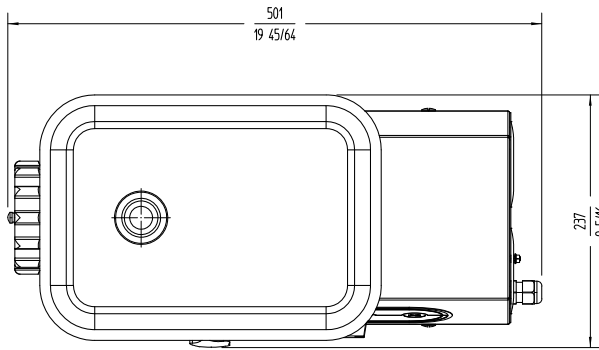
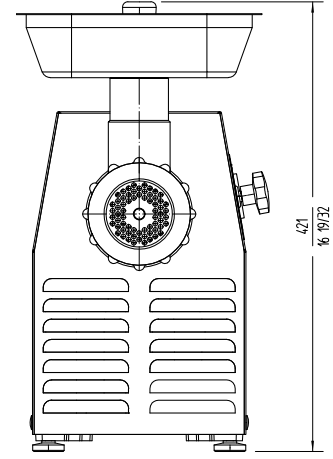
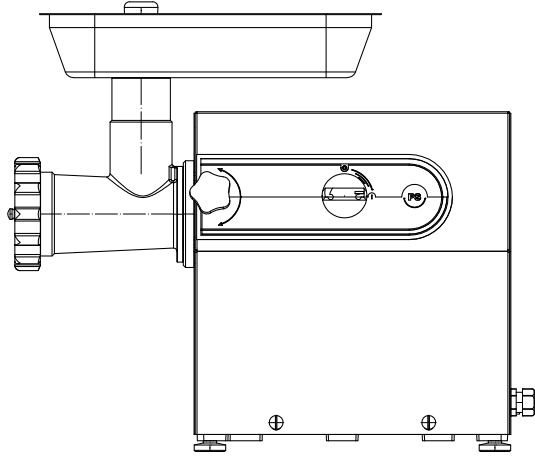

AVAILABLE MODELS

1050110 Meat mincer PS-12 230/50/1

* Ask for special versions availability

ACCESSORIES

Mesh plates

DYNAMIC PREPARATION
COMMERCIAL MEAT MINCERS



www.sammic.co.uk

Food Service Equipment Manufacturer

Unit 2, Trevanth Road
Troon Industrial Park
LE4 9LS - Leicester

uksales@sammic.com
Tel.: +44 0116 246 1900



Project	Date
Item	Qty
Approved	

product sheet
updated 06/03/2018