

robot *coupe*®



- **CMP 250 V.V.**
- **CMP 300 V.V.**
- **CMP 350 V.V.**
- **CMP 400 V.V.**
- **CMP 250 Combi**
- **CMP 300 Combi**

SUMMARY

■ WARRANTY

■ IMPORTANT WARNING

■ INTRODUCTION TO YOUR NEW POWER MIXER

■ SWITCHING ON THE APPLIANCE

- Advice on electrical connections

■ OPERATING THE APPLIANCE

- Starting and stopping the power mixer
- Continuous operation
- Variable-speed operation

■ WORKING POSITION

- Blade function
- Whisk function

■ ASSEMBLING & DISMANTLING

- Blade function
- Whisk function

■ USES & EXAMPLES

■ HYGIENE

■ CLEANING

- Motor unit
- Foot and bell
- Blades
- Whisk holder
- Whisks

■ MAINTENANCE

- Blades
- Whisks
- Foot seal
- Seal ring

■ TECHNICAL SPECIFICATIONS

- Weight
- Dimensions
- Working height
- Noise level
- Electrical data

■ SAFETY

■ PROBLEMS

■ STANDARDS

■ TECHNICAL DATA

- Electrical and wiring diagrams
- Exploded views

ROBOT-COUCPE S.N.C., LIMITED WARRANTY

Your new ROBOT-COUCPE appliance is warranted to the original buyer for a period of one year from the date of sale if you bought it from ROBOT-COUCPE S.N.C.

If you bought your ROBOT-COUCPE product from a distributor your product is covered by your distributor's warranty (Please check with your distributor terms and conditions of the warranty).

The ROBOT-COUCPE S.N.C. limited warranty is against defects in material and/or workmanship.

THE FOLLOWING ARE NOT COVERED BY THE ROBOT-COUCPE S.N.C. WARRANTY:

1 - Damage caused by abuse, misuse, dropping, or other similar damage caused by or resulting from failure to follow assembly, operating, cleaning, user maintenance or storage instructions.

2 - Labour to sharpen and/ or replacements for blades which have become blunt, chipped or worn after a normal or excessive period of use.

3 - Materials or labour to replace or repair scratched, stained, chipped, pitted, dented or discoloured surfaces, blades, knives, attachments or accessories.

4 - Any alteration, addition or repair that has not been carried out by the company or an approved service agency.

5 - Transportation of the appliance to or from an approved service agency.

6 - Labour charges to install or test new attachments or accessories (i.e., bowls, discs, blades, attachments) which have been arbitrarily replaced.

7 - The cost of changing direction-of-rotation of electric motors (Installer is responsible).

8 - SHIPPING DAMAGES. Visible and latent defects are the responsibility of the freight carrier. The consignee must inform the carrier and consignor immediately, or upon discovery in the case of latent defects.

KEEP ALL ORIGINAL CONTAINERS AND PACKING MATERIALS FOR CARRIER INSPECTION.

Neither ROBOT-COUCPE S.N.C. nor its affiliated companies or any of its distributors, directors, agents, employees, or insurers will be liable for indirect damage, losses, or expenses linked to the appliance or the inability to use it.

The ROBOT-COUCPE S.N.C. warranty is given expressly and in lieu of all other warranties, expressed or implied, for merchantability and for fitness toward a particular purpose and constitutes the only warranty made by ROBOT-COUCPE S.N.C. France.

IMPORTANT WARNING



WARNING: In order to limit accidents such as electric shocks or personal injury, and in order to limit material damage due to misuse of the appliance, please read these instructions carefully and follow them strictly. Reading the operating instructions will help you get to know your appliance and enable you to use the equipment correctly. Please read these instructions in their entirety and make sure that anyone else who may use the appliance also reads them beforehand.

UNPACKING

- **WARNING** - some of the tools are very sharp e.g. blades, etc..

INSTALLATION

- We recommend that you install your appliance on its wall frame.

CONNECTION

- Always check that your mains supply corresponds to that indicated on the identification plate on the motor unit and that it can withstand the amperage.
- Never plug your appliance into the mains supply before placing it inside the preparation bowl.

HANDLING

- Always take care when handling the blades, as they are extremely sharp.

ASSEMBLY PROCEDURES

- Follow the various assembly procedures carefully (see page 7) and make sure that all the attachments are correctly positioned.

USE

- Never try to override the safety systems.
- Never insert an object into the preparation.
- Never switch the appliance on unless it has been placed in the preparation bowl.
- Before dismantling the foot, bell or whisk always check that the power mixer is unplugged.
- We recommend that you tilt the appliance at a slight angle to prevent the bell from touching the bottom of the container.

! WARNING

Procedure to follow if the stick blender is accidentally immersed during use.

- 1) Do not touch either the power mixer, the bowl or the work surface.***
- 2) Unplug the mixer's power cord from the wall socket.***
- 3) Remove the power mixer from the preparation.***
- 4) Tilt the power mixer to drain off as much liquid as possible.***
- 5) Do not switch the power mixer back on, as there is still a risk of electrocution.***
- 6) Send the power mixer to a Robot-Coupe approved after-sales service to have the electrical components cleaned and dried.***

CLEANING

- As a precaution, always unplug your appliance before cleaning it.
- Always clean the appliance and its attachments at the end of each cycle.
- Never immerse the motor unit in water.
- For parts made from aluminum, use cleaning fluids intended for aluminum.
- For plastic parts, do not use detergents that are too alkaline (e.g., containing too much caustic soda or ammonia).
- Robot-Coupe can in no way be held responsible for the user's failure to follow the basic rules of cleaning and hygiene.

MAINTENANCE

- Before opening the motor housing, it is absolutely vital to unplug the appliance.
- Check the seals and washers regularly and ensure that the safety devices are in good working order.
- It is particularly important to maintain and check the attachments since certain ingredients contain corrosive agents, e.g. citric acid.
- Never operate the appliance if the power cord or plug has been damaged or if the appliance fails to work properly or has been damaged in any way.
- Do not hesitate to contact your local Maintenance Service if something appears to be wrong.

INTRODUCTION TO YOUR NEW POWER MIXER

Robot-Coupe has developed a whole range of power mixer. Their technical characteristics are shown in the table below.

Models	Speed variation	Mixer attachment	Whisk attachment	capacity Litres
CMP 250 V.V.	•	250 mm		15
CMP 300 V.V.	•	300 mm		30
CMP 350 V.V.	•	350 mm		45
CMP 400 V.V.	•	400 mm		73
CMP 250 Combi	•	250 mm	220 mm	15
CMP 300 Combi	•	300 mm	220 mm	30

These models are working tools that are perfectly suited to the needs of their users. **The mixer function** will allow you to make soups, vegetable purées and pulps without any problem, while you will find that the **whisk function** is ideal for making pancake batter, mayonnaise, beaten egg whites, chocolate mousse, butter sauces, whipped cream or smooth fromage frais.

The whisk attachment is equipped with a metallic gear box with a plastic body, even more resistant when processing preparations such as pan cakes.

The **variable-speed** function will enable you to adjust the speed to suit each preparation and to start the processing at a lower speed in order to reduce splashing.

The simple design of these appliances allows the assembly and dismantling of the moving parts in no time at all, to ease maintenance and cleaning.

These instructions contain important information that will enable you to extract the greatest return on your investment.

We therefore strongly advise you to read these instructions carefully before using the appliance.

SWITCHING ON THE APPLIANCE

• ADVICE ON ELECTRICAL CONNECTIONS

This class II appliance (double insulation) requires a single-phase alternating current but does not need an earthed socket. The universal-type motor is fitted with an interference suppressor.

The power supply must be protected by a differential circuit breaker and a 10 A fuse.

Check that you have a standard 10/16 A single-phase socket.

Make sure that the voltage of your power supply matches that shown on the identification plate of your appliance.

Robot-Coupe supplies these models with different types of motors:

230 V / 50 Hz for power supplies of:
220 to 240 V.

120 V / 60 Hz.

220 V / 60 Hz.

The power mixer is supplied with a single-phase plug connected to a power cord.

OPERATING THE APPLIANCE

• STARTING AND STOPPING THE POWER MIXER

1. Check that the control button (CB) is in the released position.

2. Connect the power mixer to the power supply.

3. Insert the foot into the preparation.

4. Press and hold down the safety button (SB).

5. Press the control button (CB), and the power mixer will start up.

6. Release the safety button (SB).

7. To stop the power mixer, release the control button (CB).

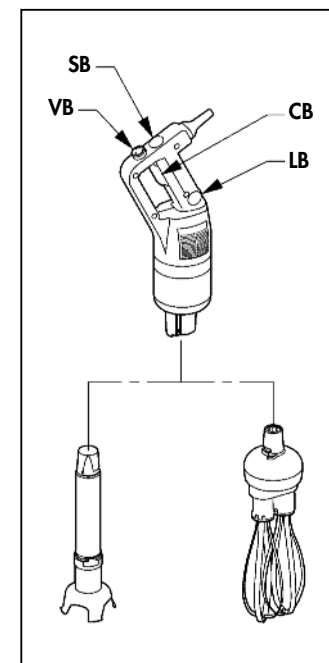

• CONTINUOUS OPERATION

Follow steps 1 to 6 above, then:

7. While the control button (CB) is in the depressed position, press the locking button (LB)

8. Release the control button (CB).

9. Release the locking button (LB), and the power mixer will function continuously.

10. To stop the power mixer, press and release the control button (CB).

• VARIABLE-SPEED OPERATION

Follow steps 1 to 6 above, then:

7. Change the speed of the motor by turning the variable speed button (VB) towards the maximum or minimum as required.

Whisk function : speed between **500** and **1800** rpm.

Mixer function : speed between **2300** and **9600** rpm.

It is advisable to start at a low speed when using the whisk.

With the self-regulating speed system, once you have selected a speed, it will remain constant, even if the consistency of your mixture changes.

WORKING POSITION

• BLADE FUNCTION

For greater control, we recommend that you hold the power mixer by the handle and the bottom of motor unit. Furthermore, we recommend that you tilt the power mixer at a slight angle to prevent the bell from touching the bottom of the container.

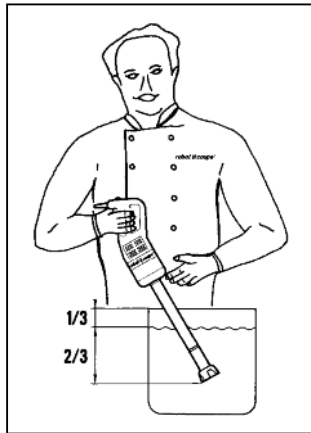

The power mixer can equally be rested against the rim of the container, but must be tilted, and the bell must not touch the bottom of the container.

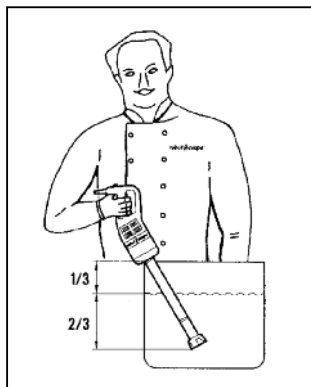

Always make sure that the bell is sufficiently immersed to avoid splashing and that the air vents of the motor unit does not come into contact with any liquid.

For optimum efficiency, two thirds of the foot should be immersed in the preparation.

• WHISK FUNCTION

You can also hold the appliance by the handle with one hand, leaving the other hand free to hold the bowl, if necessary.

While you process the preparation, we recommend that you move the whisks around in the bowl, in order to ensure that the mixture is completely homogeneous.

We strongly advise you to keep the whisks from touching the sides of the bowl. For maximum efficiency, at least one-fifth of the whisk length should be immersed. We also strongly advise you to start the processing at a low speed.

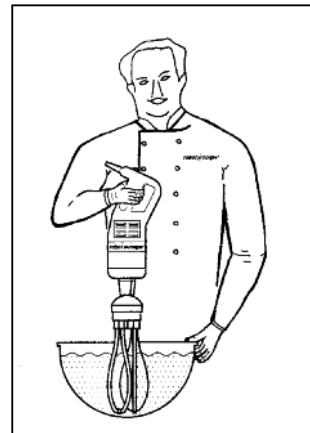

ASSEMBLING & DISMANTLING

• BLADE FUNCTION

Attaching the tube to the motor unit. (only for CMP Combi)

- Check that the appliance is not plugged in.
- Align the flat side of (A) the conical part of the tube with catch (B) into the aluminium casing.
- Insert the whole of the conical part (C) of the tube into the aluminium casing.
- Turn the tube in the direction of the arrow (see figure) until it is locked into place moderately tightly.

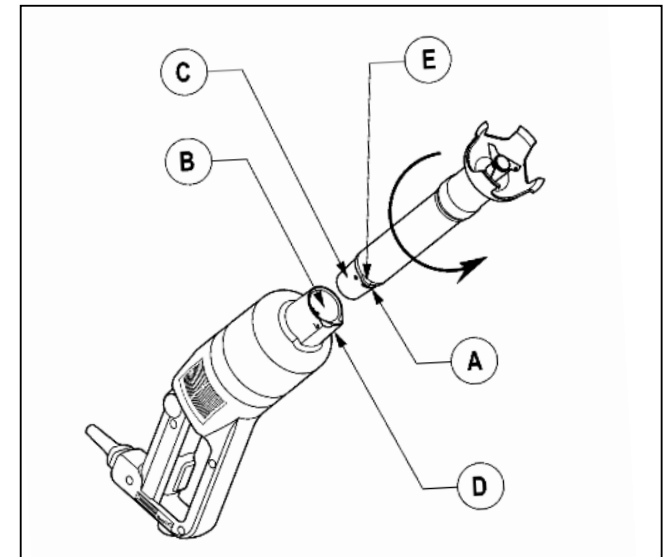

Removing the tube from the motor unit (only for CMP Combi)

- Check that the appliance is unplugged.
- Turn the tube in the opposite direction to that used when attaching it.
- When it will go no further, remove the tube of the aluminium casing.

Attaching the bell from the tube

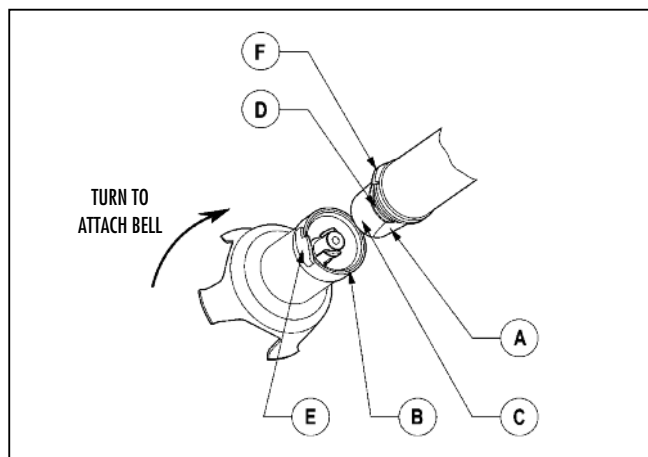

- Check that the machine is not plugged in.
- Align the flat side of (A) the conical part of the tube with catch (B) the inside of the bell.
- Insert the conical part (C) into the bell. With the washer touching the tube seal (D), turn the bell in the direction of the arrow (see above figure) to lock the bell lug (E) and tube lug (F) together moderately tightly.

Removing the bell from the tube

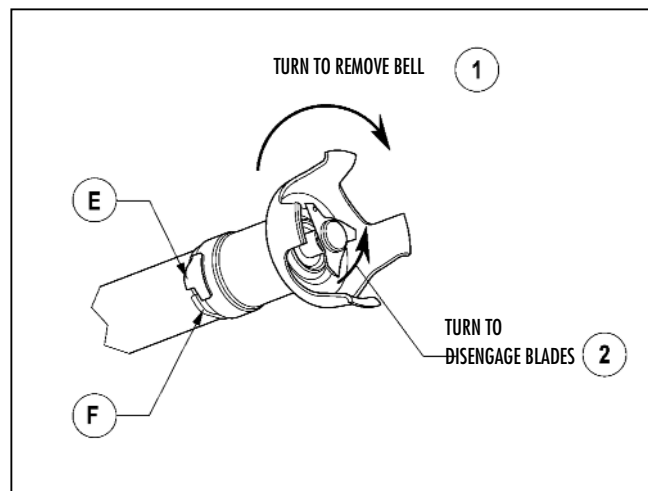

- Check that the machine is not plugged in.
- Turn the bell in the direction of arrow ① (see next figure) to separate the bell lug (E) from the tube lug (F). Remove the bell.
- If jammed, turn the blades inside the bell in the direction of arrow ② to disengage them from the drive shaft.

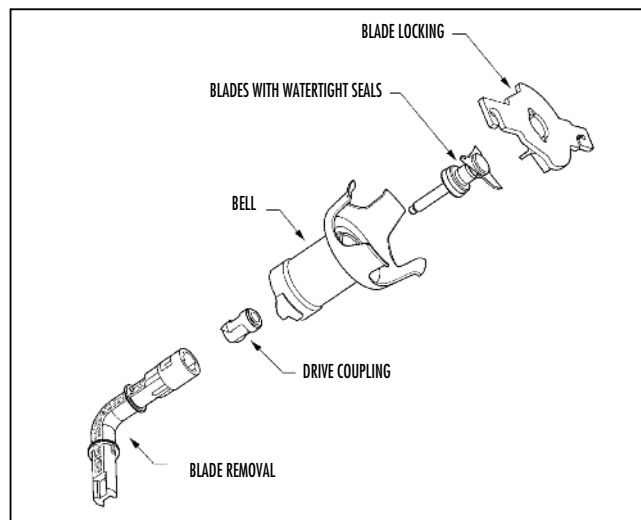

Removing the blade

- To remove the blade safely, hold them with the tool provided or an oven glove or a thick cloth.
- Using the removal tool, unscrew the drive coupling.
- As soon as the drive coupling has been unscrewed, the blade can be removed for cleaning.

• WHISK FUNCTION (only for CMP Combi) Attaching the whisk holder to the motor unit.

- Check that the machine is not plugged in.
- Align the flat side (A) of the conical part (C) of the whisk holder with the catch (B) on the inside of the aluminium casing.

- Insert the whole of the conical part (C) of the whisk holder into the aluminium casing.
- Turn the whisk holder in the direction of the arrow (see figure) until it is locked into place moderately tightly.

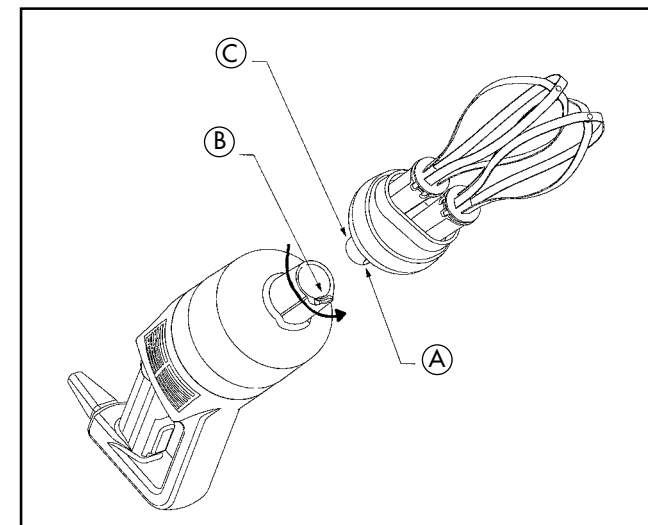

Removing the casing

- Check that the machine is not plugged in.
- Turn the whisk holder in the opposite direction to that used when attaching it.
- When it will go no further, remove the whisk holder from the aluminium casing.

Fitting the whisks into the whisk holder

- Grasp the holder in one hand.
- With the other hand, take the first whisk and insert the shaft (A) into the bore B of the whisk holder drive shaft. Make sure the drive lugs (D) are properly aligned with the notches.
- As you push the whisk into the whisk holder drive shaft (C), rotate it slightly in order to slot the drive lugs into the notches (D) of the drive shaft (C), thereby locking the whisk into place inside the shaft.

- To check that the whisk is properly fixed inside the shaft (C), gently tug the metal wires.
- Repeat this procedure with the second whisk. If you cannot push it in properly, remove it, rotate it 90° and start again.

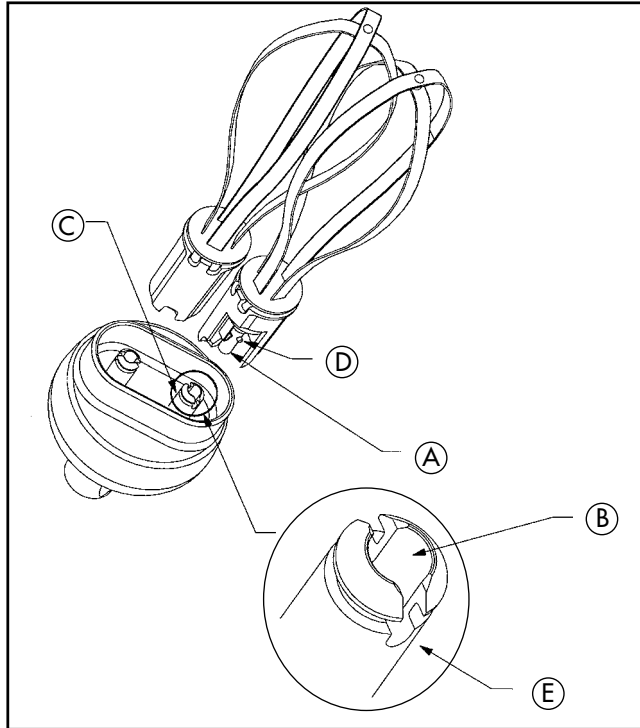

Removing the whisks from the whisk holder

Pull the ejector (A) in direction to the arrow, gripping the ejector in one hand and the holder (B) in the other.

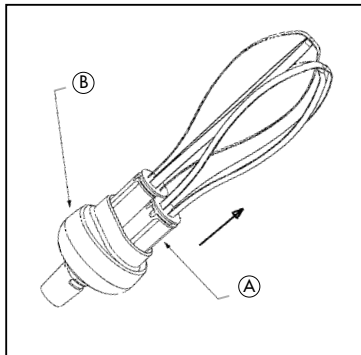

Removing the ejector

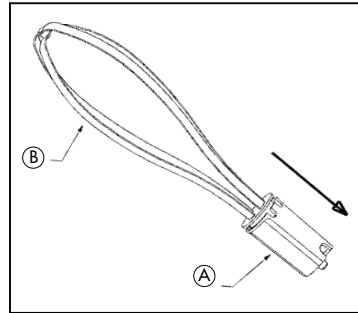

- Hold the whisk by the wires (B) in one hand.
- With the other hand, pull the ejector (A) in the direction of the arrow (see figure).

The foot, the blades and the whisks can be entirely dismantled, (Robot-Coupe's exclusive patented system), thereby ensuring easy cleaning, perfect hygiene and simple maintenance.

USES & EXAMPLES

The mixer function makes it possible to carry out all types of processing in the minimum of time, while the whisk function enables you to whisk and mix the preparation. We thus recommend that you supervise all food preparations carefully in order to obtain the best results.

CATERING AND RESTAURANT WORK

Blade Function

- Soups
- Vegetable purees : carrots, spinach, celery, turnips, French beans, etc.
- Mousses : vegetable, fish
- Fruit compotes
- Sauces : green, rouille, remoulade, cream emulsions, tomato or parsley
- Bisques : langoustines and shellfish
- Pancake batter

Whisk function

- Mashed potatoes (fresh or instant).
- Pancake batter
- Mayonnaise
- Beaten egg whites
- Chocolate mousse
- Butter sauces
- Whipped cream
- Smooth fromage frais
- Mashed potato (fresh or instant)

CHEMICAL & PHARMACEUTICAL LABORATORY WORK

- Mixing : making ointments, creams, paste..., emulsions.

HYGIENE

The equipment must be clean at all stages of production.

It is vital to clean the power mixer thoroughly between each job using a detergent or disinfectant.

• N.B. NEVER USE PURE BLEACH

- Dilute the detergent/disinfectant following the manufacturer's instructions on the label.
- Scrub well if necessary.
- Leave the disinfectant/detergent to take effect if necessary.
- Rinse thoroughly.
- Dry properly using a clean cloth.

CLEANING



WARNING

As a precaution, always unplug your appliance before cleaning it (risk of electrocution).

After using the power mixer in a hot preparation, cool the bottom of the foot in cold water before dismantling the bell from the foot.

After completion of preparation, clean immediately to prevent food from sticking to surfaces.

• MOTOR UNIT

Never put the motor unit and its handle in water, clean them with a damp cloth or a sponge.

• FOOT AND BELL

It is possible to proceed in two ways:

• Simple cleaning procedure

- Place the foot and bell into a suitable container with water and switch on for a few seconds to clean the bell and the foot.
- After unplugging the appliance - essential -, making sure that no water finds its way into the foot, detach the bell from the foot to avoid a build-up of condensation.

• Complete cleaning procedure

- Unplug the power mixer.
- Rinse the bell under the tap.
- Remove the bell from the foot, then remove the blades. Be careful to avoid damaging the surface of the blade shaft and the watertight seals. Do not use too strong a detergent when cleaning the parts.
- Ensure that all the different parts are thoroughly dried before reassembly.

• BLADES

The blades can be removed from the bell for thorough cleaning.

Always dry the blades thoroughly after cleaning to avoid spotting.

• WHISK HOLDER

Never immerse the whisk holder in water. Clean it with a slightly damp cloth or sponge.

Never clean the whisk holder in a dishwasher.

• WHISKS

The whisks can be cleaned either by hand or in a dishwasher.

To ensure effective cleaning, we advise you to remove the whisk ejector.

! I M P O R T A N T

Check that your detergent is suitable for cleaning plastic parts. Some washing agents are too alkaline (e.g. high levels of caustic soda or ammonia) and totally incompatible with certain types of plastic, causing them to deteriorate rapidly.

MAINTENANCE

• BLADES

The performance of the cut essentially depends on the state of your blades and their wear. The blades are subject to wear and as such need to be replaced from time to time to ensure the consistent quality of the end product.

You are also advised to change, at the same time, the washer and the watertight seals.

• WHISKS

The success of your preparation will depend essentially on the state of the metal wires and their amount of wear and tear. They should therefore be replaced from time to time in order to ensure optimum quality of the finished product.

• FOOT SEAL

In order to maintain a perfect watertight seal between the foot and the bell it is necessary to check the wear of the seal regularly and replace it if necessary.

• WASHER

The washer can be greased using a suitable food safe lubricant.

In order to maintain a perfect watertightness it is necessary to check the wear of the washer, and if necessary, to replace it.

! W A R N I N G

From time to time, check:

- The state of the 3 buttons' watertight membranes. Even the tiniest cracks will allow liquid to seep in.
- The state of the blender housing. This, should not show any signs of cracking or any abnormal openings which could allow access to the live components.

TECHNICAL SPECIFICATIONS

• WEIGHT

	Net weight	Gross weight
CMP 250 V.V.	3.1 kg	3.7 kg
CMP 300 V.V.	3.2 kg	3.8 kg
CMP 350 V.V.	3.5 kg	4.0 kg
CMP 400 V.V.	3.6 kg	4.1 kg

CMP 250 Combi		
with mixer	3.2 kg	5.4 kg
with whisk	3.4 kg	
CMP 300 Combi		
with mixer	3.4 kg	5.5 kg
with whisk	3.4 kg	

• DIMENSIONS (in mm)

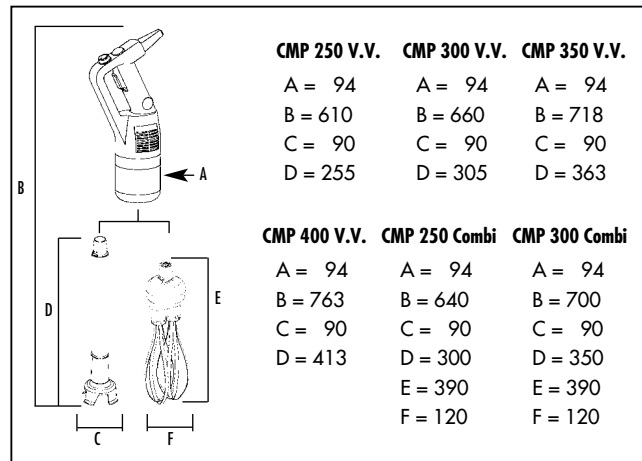

• WORKING HEIGHT

We recommend that you ensure that the container is placed on a stable and solid work surface.

• NOISE LEVEL

The equivalent continuous sound level when the foot is not immersed in anything is less than 70 dB (A).

• ELECTRICAL DATA

Single-phase machine CMP 250 V.V./CMP 250 Combi

Motor	Mixer Speed (rpm)	Whisk Speed (rpm)	Power (Watts)	Intensity (Amp.)
230 V/50 Hz	2300 to 9600	500 to 1800	310	1.4
120 V/60 Hz	2300 to 9600	500 to 1800	280	2.6
220 V/60 Hz	2300 to 9600	500 to 1800	250	1.3

Single-phase machine CMP 300 V.V./CMP 300 Combi

Motor	Mixer Speed (rpm)	Whisk Speed (rpm)	Power (Watts)	Intensity (Amp.)
230 V/50 Hz	2300 to 9600	500 to 1800	350	1.6
120 V/60 Hz	2300 to 9600	500 to 1800	320	2.9
220 V/60 Hz	2300 to 9600	500 to 1800	290	1.4

Single-phase machine CMP 350 V.V.

Motor	Mixer Speed (rpm)	Power (Watts)	Intensity (Amp.)
230 V/50 Hz	2300 to 9600	400	1.7
120 V/60 Hz	2300 to 9600	350	3.1
220 V/60 Hz	2300 to 9600	340	1.6

Single-phase machine CMP 400 V.V.

Motor	Mixer Speed (rpm)	Power (Watts)	Intensity (Amp.)
230 V/50 Hz	2300 to 9600	420	1.9

SAFETY

! WARNING

The blades are sharp tools, handle them with care.

ROBOT-COUPÉ power mixers are equipped with a safety system comprising of a :

- safety control button
- safeties on motor: thermal and overload protection
- no volt release safety.

• Safety control button

This safety mechanism prevents any unintentional starting of the power mixer. In fact, it is necessary to press down two buttons to start the power mixer. In order to start the machine, read the paragraph entitled OPERATING THE APPLIANCE (page 6).

• Thermal and overload protection

If there is an obstruction in the container (a spoon or utensil) or the machine is exposed to over use / overload, the thermal safety mechanism automatically stop the motor. In this case, wait for the power mixer to cool down completely before restarting, see paragraph entitled OPERATING THE APPLIANCE (page 6).

• No volt release a supply failure

In the event of a power cut or after the machine has been unplugged, the power mixer will not restart by itself. It is necessary to follow the steps in the paragraph entitled OPERATING THE APPLIANCE (page 6).

! REMINDER

Never try to override the locking and safety mechanisms.

Never insert an object into the preparation.

Never switch the appliance on unless it has been placed in the preparation bowl.

Before dismantling the foot and bell, always check that the power mixer is unplugged.

We recommend that you tilt the power mixer at a slight angle to prevent the bell from touching the bottom of the container.

PROBLEMS

At first, try to identify precisely what has caused the power mixer to stop.

- **If it is due to a powercut if the appliance has been unplugged**

- Release the control button (CB).
- Check the power supply.
- Restart the power mixer following the paragraph entitled OPERATING THE APPLIANCE (page 6).

- **If it is due to overheating of the machine**

- Release the control button (CB).
- Unplug the power mixer.
- Wait a few minutes for the motor to cool down and the thermal safety mechanism to be reset.
- Restart the power mixer following the paragraph entitled OPERATING THE APPLIANCE (page 6).

- **If you cannot locate the cause of the problem**

- Release the control button (CB).- Unplug the power mixer.
- Check :
 - the plug
 - that the blades are free to rotate in the bell,
 - the state of the power cord,
 - that the drive shaft is free to rotate. To do this, remove the bell and test the rotation of the end of the drive shaft manually.

If a malfunction occurs which is not on our list of possible faults, consult your retailer or return the appliance to the after-sales service.

STANDARDS

MACHINES IN COMPLIANCE WITH:

- The following European directives and related national legislation:

- Modified "machinery" directive 2006/42/EC,
- "Low voltage" directive 2006/95/EEC,
- "EMC" directive 2004/108/EC,
- "Materials and parts in food contact" directive 89/109/EEC,
- Commission Directive 2002/72/EC of 6 August 2002 relating to plastic materials and articles intended to come into contact with foodstuffs.
- "ROHS" directive 2002/95/EC,
- "DEEE" directive 2002/96/EC.

- The following European harmonized standards and standards setting out health and safety rules:

- EN ISO 12100 1 - 2 - 2003
- EN 60204 -1 (2006),
- For hand-held blenders and whisk: EN 12853.

INDEXES OF PROTECTION:

- IP 55 for the switches.
- IP 34 for the machines.

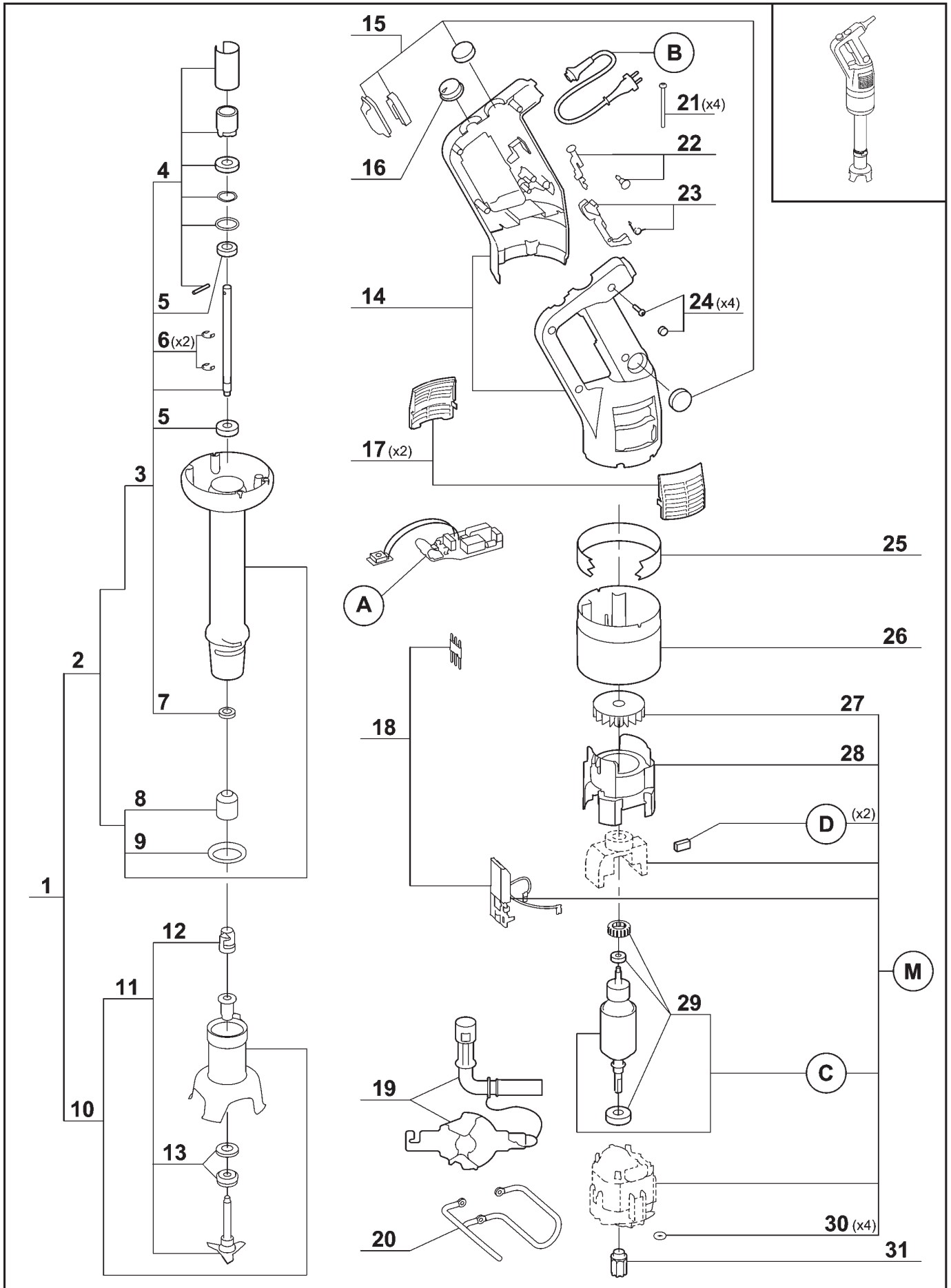

Index	Pièce / Part	Désignation	Description
1	89 079	PIED COMPLET CMP 250	CMP 250 COMPLETE FOOT
2	89 652	PIED CMP 250 EQUIPE	CMP 250 FOOT
3	89 685	ARBRE D'ENTRAINEMENT CMP 250	CMP250 DRIVING SHAFT
4	89 643	KIT PIED MPC/CMP/CMPC	MPC/CMP/CMPC FOOT KIT
5	89 645	ROULEMENT INOX 608 2RS	STAINL ST BEAR 608 2RS
6	89 647	ANNEAU "E" (x2)	RING "E" (x2)
7	89 646	JOINT A LEVRE 8x18x5	SEAL 8x18x5
8	89 626	CAGE D'ENTRAINEMENT MP/CMP	MP/CMP DRIVING FRAME
9	89 628	JOINT DE PIED MP/CMP	FOOT SEAL
10	89 678	CLOCHE CMP EQUIPEE	CMP BELL COVER
11	89 676	COUTEAU CMP	CMP BLADE
12	89 627	MOYEU D'ENTRAINEMENT MP/CMP	MP/CMP DRIVING HUB
13	89 642	GARNITURE D'ETANCHEITE	SEAL RING
14	89 547	KIT POIGNEES (G+D)+VIS+CACHE CMP	CMP HANDLES (L+R) KIT+SCREW+ CAP SCREW CMP
15	89 533	KIT ETANCHEITE MP/CMP+VIS+CACHE VIS	MP/CMP WATERPROOFNESS KIT+SCREW+CAP SCREW
16	89 536	BOUTON VARIATEUR MP/CMP.+VIS+CACHE VIS	MP/CMP VARIATOR SWITCH+SCREW+CAP SCREW
17	89 546	KIT GRILLES CMP (x2)	CMP VENT COVERS KIT (x2)
18	89 548	KIT CONNECTION+VIS+CACHE VIS	CONNECTOR KIT+SCREW+CAP SCREW
19	89 662	OUTILLAGE DE DEMONTAGE MP/CMP	MP/CMP DISMOUNT TOOL
20	89 637	SUPPORT MURAL CMP	CMP WALL SUPPORT
21	89 623	VIS M4x95 CMP (x4)	CMP SCREW M4x95 (x4)
22	89 530	KIT BOUTON MP/CMP+VIS+CACHE VIS	MP/CMP KNOBS KIT +SCREW+CAP SCREW KIT
23	89 531	KIT LEVIER CDE MPC/CMP+VIS+CACHE VIS	MPC/CMP COMMAND ARM KIT+SCREW+CAP SCREW
24	89 532	KIT VIS POIG MP/CMP (x4)	MP/CMP HANDLE SCREW (x4)
25	89 605	VIROLE CMP 250 V.V.	CMP250VV FERRULE
26	89 612	VIROLE MOTEUR CMP	CMP MOTOR FERRULE
27	89 576	VENTILATEUR CMP	CMP VENTILATOR
28	89 570	CONDUIT VENTILATEUR CMP	CMP VENTILATOR PIPE
29	89 679	ROULEMENT MOTEUR CMP	CMP MOTOR BEARING
30	89 639	JOINT TORIQUE Ø2x1,5 (x4)	SEAL Ø2x1,5 (x4)
31	89 632	MOYEU D'ENTRAINEMENT MPC	MPC DRIVING HUB

Index	Désignation	Description
A	PLATINE	CIRCUIT BOARD
B	CABLE D'ALIMENTATION	POWER CORD
C	INDUIT	INDUCED CIRCUIT
D	CHARBONS (x2)	BRUSHES (x2)
M	MOTEUR	MOTOR

Machine	Voltage	A	B	C	D	M			
34 248 / 34 248 A Arabie	220/60/1	89 753	89 539	89 759	89 575	89 767			
34 244 / 34 244 A			89 538						
34 240 / 34 240 A	230/50/1	89 751	89 542						
34 246 / 34 246 A Suisse			89 539						
34 241 / 34 241 A UK			89 540						
34 242 / 34 242 A Aust	240/50/1	89 752	89 541				89 760		89 769
34 245 / 34 245 A			89 522						
34 249 / 34 249 A Japon	120/60/1								

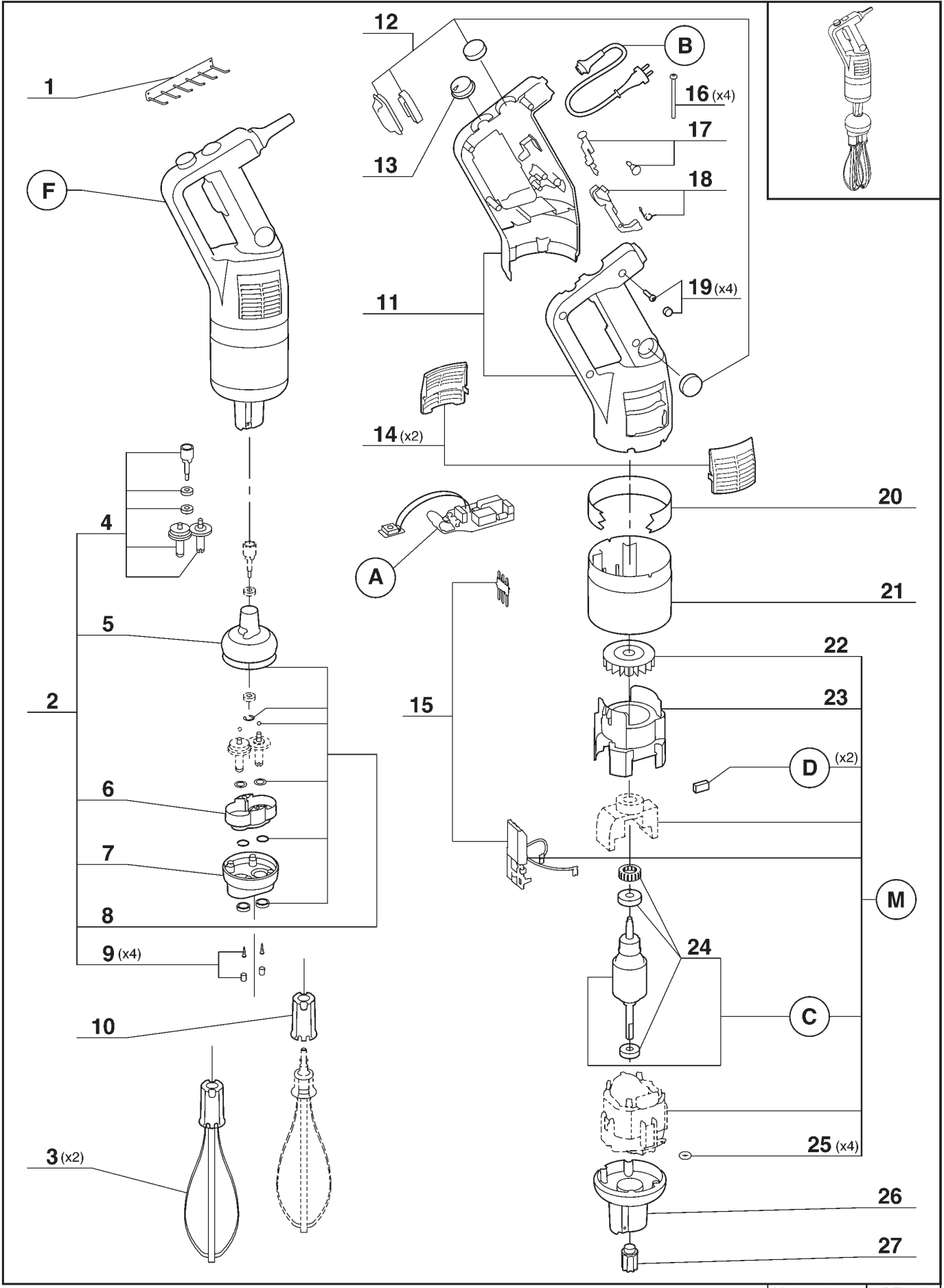

Index	Pièce / Part	Désignation	Description
1	89 630	SUPPORT MURAL MPC	MPC WALL SUPPORT
2	89 651	BOITE FOUET CMP	CMP WHIP BOX
3	89 649	FOUETS CMP (x2)	CMP WHIPS (x2)
4	89 549	KIT PIGNONS + BAGUE + ROUL ^{ent} +VIS+CACHE-VIS B.F.	GEARS+RING+BEARING+SCREW+CAP SCREW KIT
5	89 379	COQUE SUP BF MP/CMP+VIS+CACHE VIS	MP/CMP BF UPPER BODY+SCREW+CAP SCREW
6	89 385	FLASQUE+VIS+CACHE-VIS	PLATE+SCREW+CAP SCREW
7	89 746	COQUE INF PLAST BF CMP	BF CMP LOWER BODY PLAS
8	89 545	KIT JOINT RONDELLE BF +VIS+CACHE VIS	BF SEAL WASHER KIT +SCREW+CAP SCREW KIT
9	89 389	VIS+CVIS BF MP CMP	BF SCREW+CAP SCREW
10	89 552	KIT EJECT FOUET MP/CMP	MP/CMP WHIP EJECTOR
11	89 547	KIT POIGNEES (G+D)+VIS+CACHE CMP	CMP HANDLES (L+R) KIT+SCREW+ CAP SCREW CMP
12	89 533	KIT ETANCHEITE MP/CMP+VIS+CACHE VIS	MP/CMP WATERPROOFNESS KIT+SCREW+CAP SCREW
13	89 536	BOUTON VARIATEUR MP/CMP.+VIS+CACHE VIS	MP/CMP VARIATOR SWITCH+SCREW+CAP SCREW
14	89 546	KIT GRILLES CMP (x2)	CMP VENT COVERS KIT (x2)
15	89 548	KIT CONNECTION CMP+VIS+CACHE VIS	CMP CONNECTOR KIT+SCREW+CAP SCREW
16	89 623	VIS M4x95 CMP (x4)	CMP SCREW M4x95 (x4)
17	89 530	KIT BOUTON MP/CMP+VIS+CACHE VIS	MP/CMP KNOBS KIT +SCREW+CAP SCREW KIT
18	89 531	KIT LEVIER CDE MPC/CMP+VIS+CACHE VIS	MPC/CMP COMMAND ARM KIT+SCREW+CAP SCREW
19	89 532	KIT VIS POIG MP/CMP (x4)	MP/CMP HANDLE SCREW (x4)
20	89 611	VIROLE CMP 250 FW	FERRULE
21	89 612	VIROLE MOTEUR CMP	CMP MOTOR FERRULE
22	89 576	VENTILATEUR CMP	CMP VENTILATOR
23	89 570	CONDUIT VENTILATEUR CMP	CMP VENTILATOR PIPE
24	89 679	ROULEMENT MOTEUR CMP	CMP MOTOR BEARING
25	89 639	JOINT TORIQUE Ø2x1,5 (x4)	SEAL Ø2x1,5 (x4)
26	89 641	CARTER ALU CMP	CMP ALUMINIUM CASING
27	89 661	MOYEU D'ENTRAINEMENT CMPC	CMPC DRIVING HUB

Index	Désignation	Description
A	PLATINE	CIRCUIT BOARD
B	CABLE D'ALIMENTATION	POWER CORD
C	INDUIT	INDUCED CIRCUIT
D	CHARBONS (x2)	BRUSHES (x2)
F	BLOC MOTEUR	BLOCK MOTOR
M	MOTEUR	MOTOR

Machine	Voltage	A	B	C	D	F	M
34 330 / 34 330 A	230/50/1	89 751	89 538	89 759	89 575	29 823	89 767
34 337 / 34 337 A Suede	230/50/1	89 751	89 405	89 759	89 575	29 764	89 767

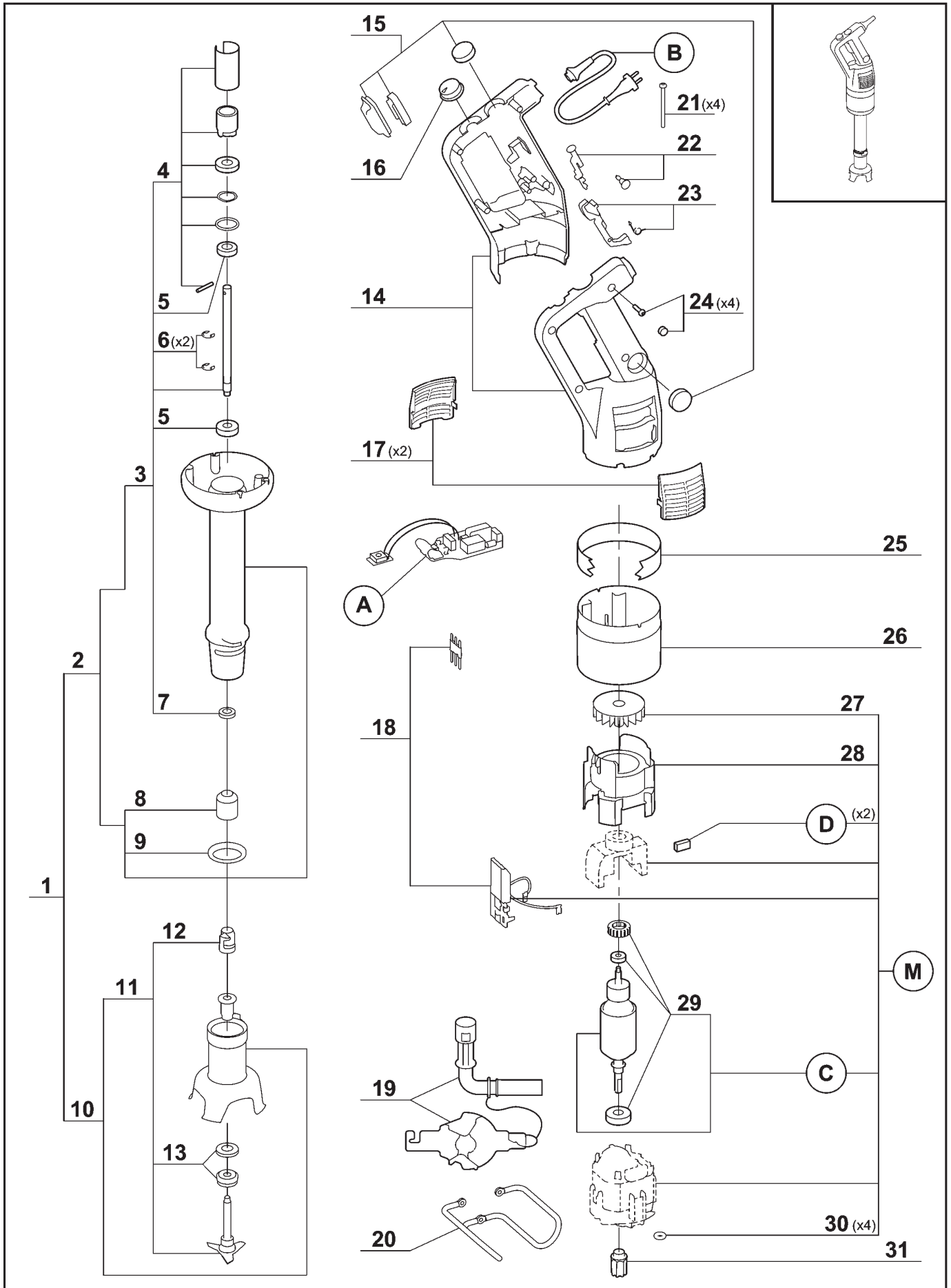

Index	Pièce / Part	Désignation	Description
1	89 080	PIED CMP 300 COMPLET	CMP 300 COMPLETE FOOT
2	89 653	PIED CMP 300 EQUIPE	CMP 300 FOOT
3	89 686	ARBRE D'ENTRAINEMENT CMP 300	CMP 300 DRIVING SHAFT
4	89 643	KIT PIED MPC/CMP/CMPC	MPC/CMP/CMPC FOOT KIT
5	89 645	ROULEMENT INOX 608 2RS	STAINL ST BEAR 608 2RS
6	89 647	ANNEAU "E" (x2)	RING "E" (x2)
7	89 646	JOINT A LEVRE 8x18x5	SEAL 8x18x5
8	89 626	CAGE D'ENTRAINEMENT MP/CMP	MP/CMP DRIVING FRAME
9	89 628	JOINT DE PIED MP/CMP	FOOT SEAL
10	89 678	CLOCHE CMP EQUIPEE	CMP BELL COVER
11	89 676	COUTEAU CMP	CMP BLADE
12	89 627	MOYEU D'ENTRAINEMENT MP/CMP	MP/CMP DRIVING HUB
13	89 642	GARNITURE D'ETANCHEITE	SEAL RING
14	89 547	KIT POIGNEES (G+D)+VIS+CACHE CMP	CMP HANDLES (L+R) KIT+SCREW+ CAP SCREW CMP
15	89 533	KIT ETANCHEITE MP/CMP+VIS+CACHE VIS	MP/CMP WATERPROOFNESS KIT+SCREW+CAP SCREW
16	89 536	BOUTON VARIATEUR MP/CMP.+VIS+CACHE VIS	MP/CMP VARIATOR SWITCH+SCREW+CAP SCREW
17	89 546	KIT GRILLES CMP (x2)	CMP VENT COVERS KIT (x2)
18	89 548	Kit CONNECTEUR+VIS+CACHE VIS	CONNECTOR KIT+SCREW+CAP SCREW
19	89 662	OUTILLAGE DE DEMONTAGE MP/CMP	MP/CMP DISMOUNT TOOL
20	89 637	SUPPORT MURAL CMP	CMP WALL SUPPORT
21	89 623	VIS M4x95 CMP (x4)	CMP SCREW M4x95 (x4)
22	89 530	KIT BOUTON MP/CMP+VIS+CACHE VIS	MP/CMP KNOBS KIT +SCREW+CAP SCREW KIT
23	89 531	KIT LEVIER CDE MPC/CMP+VIS+CACHE VIS	MPC/CMP COMMAND ARM KIT+SCREW+CAP SCREW
24	89 532	KIT VIS POIG MP/CMP (x4)	MP/CMP HANDLE SCREW (x4)
25	89 606	VIROLE CMP 300 V.V.	CMP 300 VV FERRULE
26	89 612	VIROLE MOTEUR CMP	CMP MOTOR FERRULE
27	89 576	VENTILATEUR CMP	CMP VENTILATOR
28	89 570	CONDUIT VENTILATEUR CMP	CMP VENTILATOR PIPE
29	89 679	ROULEMENT MOTEUR CMP	CMP MOTOR BEARING
30	89 639	JOINT TORIQUE Ø2x1,5 (x4)	SEAL Ø2x1,5 (x4)
31	89 632	MOYEU D'ENTRAINEMENT MPC	MPC DRIVING HUB

Index	Désignation	Description
A	PLATINE	CIRCUIT BOARD
B	CABLE D'ALIMENTATION	POWER CORD
C	INDUIT	INDUCED CIRCUIT
D	CHARBONS (x2)	BRUSHES (x2)
M	MOTEUR	MOTOR

Machine	Voltage	A	B	C	D	M
34 238 / 34238 A Arabie	220/60/1	89 753	89 539	89 759	89 575	89 761
34 234 / 34234 A			89 538			
34 230 / 34 230 A	230/50/1	89 751	89 542			
34 236 / 34236 A Suisse			89 539			
34 231 / 34 231 A UK	240/50/1	89 752	89 540			
34 232 / 34232 A Aust			89 541			
34 235 / 34235 A	120/60/1	89 752	89 522			
34 239 / 34239 A Japon						

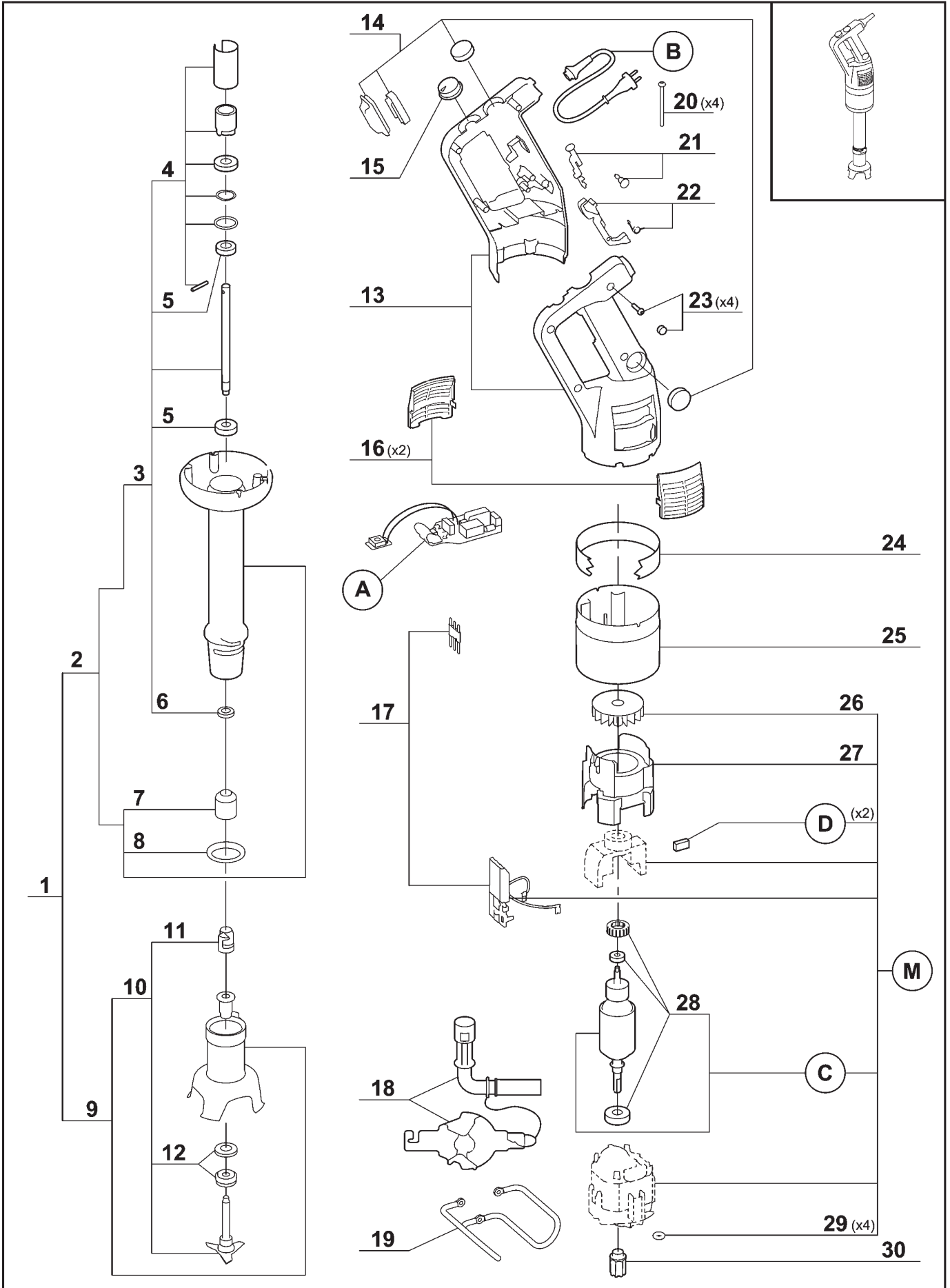

Index	Pièce / Part	Désignation	Description
1	89 081	PIED CMP 350 COMPLET	CMP 350 COMPLETE FOOT
2	89 654	PIED CMP 350 EQUIPE	CMP 350 FOOT
3	89 687	ARBRE D'ENTRAINEMENT CMP 350	CMP 350 DRIVING SHAFT
4	89 643	KIT PIED MPC/CMP/CMPC	MPC/CMP/CMPC FOOT KIT
5	89 645	ROULEMENT INOX 608 2RS	STAINL ST BEAR 608 2RS
6	89 646	JOINT A LEVRE 8x18x5	SEAL 8x18x5
7	89 626	CAGE D'ENTRAINEMENT MP/CMP	MP/CMP DRIVING FRAME
8	89 628	JOINT DE PIED MP/CMP	FOOT SEAL
9	89 678	CLOCHE CMP EQUIPEE	CMP BELL COVER
10	89 676	COUTEAU CMP	CMP BLADE
11	89 627	MOYEU D'ENTRAINEMENT MP/CMP	MP/CMP DRIVING HUB
12	89 642	GARNITURE D'ETANCHEITE	SEAL RING
13	89 547	KIT POIGNEES (G+D)+VIS+CACHE CMP	CMP HANDLES (L+R) KIT+SCREW+ CAP SCREW CMP
14	89 533	KIT ETANCHEITE MP/CMP+VIS+CACHE VIS	MP/CMP WATERPROOFNESS KIT+SCREW+CAP SCREW
15	89 536	BOUTON VARIATEUR MP/CMP.+VIS+CACHE VIS	MP/CMP VARIATOR SWITCH+SCREW+CAP SCREW
16	89 546	KIT GRILLES CMP (x2)	CMP VENT COVERS KIT (x2)
17	89 548	Kit CONNECTEUR+VIS+CACHE VIS	CONNECTOR KIT
18	89 662	OUTILLAGE DE DEMONTAGE MP/CMP	MP/CMP DISMOUNT TOOL
19	89 637	SUPPORT MURAL CMP	CMP WALL SUPPORT
20	89 623	VIS M4x95 CMP (x4)	CMP SCREW M4x95 (x4)
21	89 530	KIT BOUTON MP/CMP+VIS+CACHE VIS	MP/CMP KNOBS KIT +SCREW+CAP SCREW KIT
22	89 531	KIT LEVIER CDE MPC/CMP+VIS+CACHE VIS	MPC/CMP COMMAND ARM KIT+SCREW+CAP SCREW
23	89 532	KIT VIS POIG MP/CMP (x4)	MP/CMP HANDLE SCREW (x4)
24	89 607	VIROLE CMP 350 V.V.	CMP 350 VV FERRULE
25	89 612	VIROLE MOTEUR CMP	CMP MOTOR FERRULE
26	89 576	VENTILATEUR CMP	CMP VENTILATOR
27	89 570	CONDUIT VENTILATEUR CMP	CMP VENTILATOR PIPE
28	89 679	ROULEMENT MOTEUR CMP	CMP MOTOR BEARING
29	89 639	JOINT TORIQUE Ø2x1,5 (x4)	SEAL Ø2x1,5 (x4)
30	89 632	MOYEU D'ENTRAINEMENT MPC	MPC DRIVING HUB

Index	Désignation	Description
A	PLATINE	CIRCUIT BOARD
B	CABLE D'ALIMENTATION	POWER CORD
C	INDUIT	INDUCED CIRCUIT
D	CHARBONS (x2)	BRUSHES (x2)
M	MOTEUR	MOTOR

Machine	Voltage	A	B	C	D	M
34 258 / 34 258 A Arabie	220/60/1	89 753	89 539	89 759	89 575	89 768
34 254 / 34 254 A			89 538			
34 250 / 34 250 A	230/50/1	89 751	89 542			
34 256 / 34 256 A Suisse			89 539			
34 251 / 34 251 A UK	240/50/1	89 751	89 540			
34 252 / 34 252 A Aust						
34 255 / 34 255 A	120/60/1	89 752	89 541			
34 259 / 34 259 A Japon			89 522			

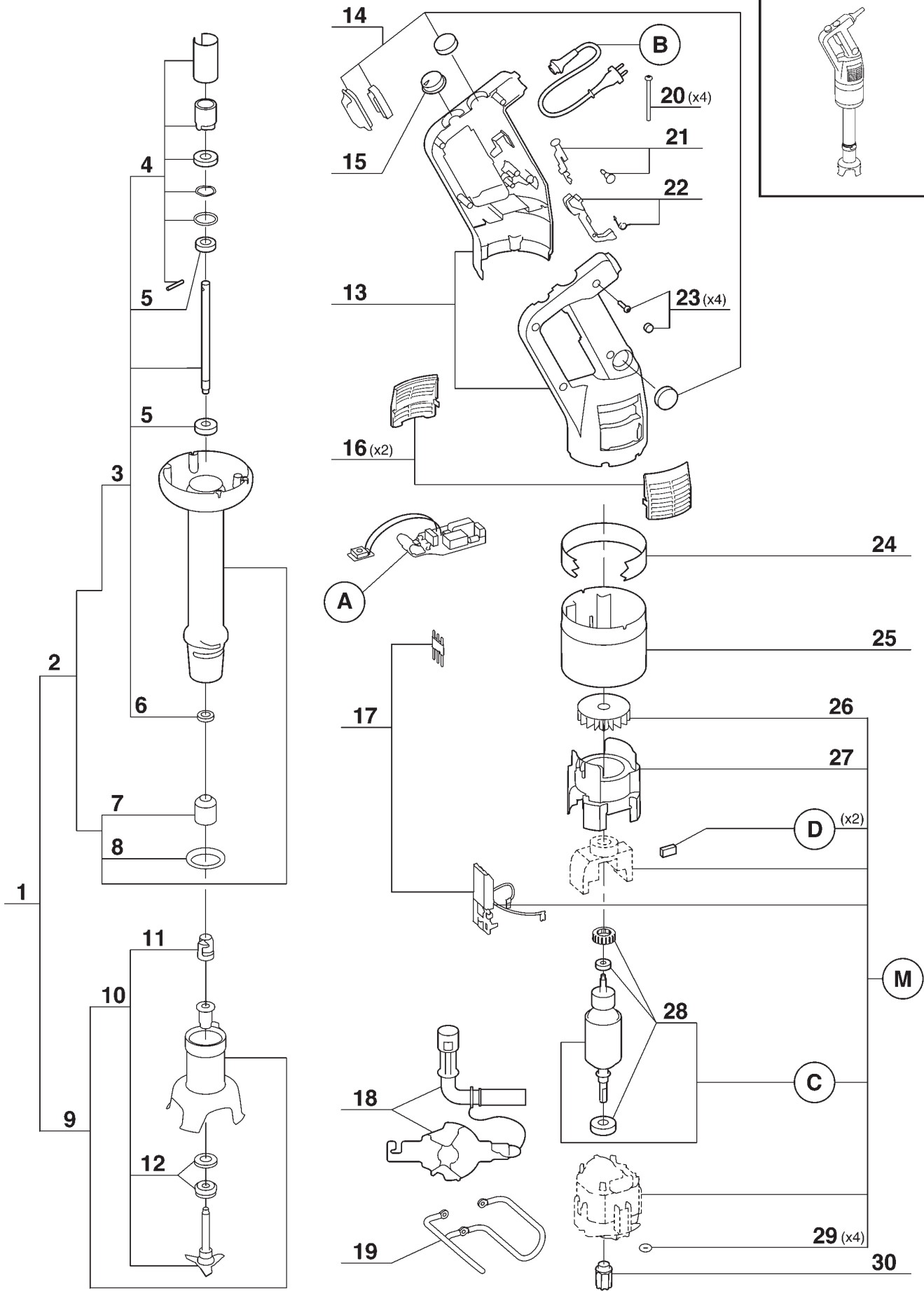
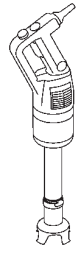

Index	Pièce / Part	Désignation	Description
1	89 082	PIED CMP 400 COMPLET	CMP 400 COMPLETE FOOT
2	89 655	PIED CMP 400 EQUIPE	CMP 400 FOOT
3	89 151	ARBRE D'ENTRAINEMENT CMP 400	CMP 400 DRIVING SHAFT
4	89 643	KIT PIED MPC/CMP/CMPC	MPC/CMP/CMPC FOOT KIT
5	89 645	ROULEMENT INOX 608 2RS	STAINL ST BEAR 608 2RS
6	89 646	JOINT A LEVRE 8x18x5	SEAL 8x18x5
7	89 626	CAGE D'ENTRAINEMENT MP/CMP	MP/CMP DRIVING FRAME
8	89 628	JOINT DE PIED MP/CMP	FOOT SEAL
9	89 678	CLOCHE CMP EQUIPEE	CMP BELL COVER
10	89 676	COUTEAU CMP	CMP BLADE
11	89 627	MOYEU D'ENTRAINEMENT MP/CMP	MP/CMP DRIVING HUB
12	89 642	GARNITURE D'ETANCHEITE	SEAL RING
13	89 547	KIT POIGNEES (G+D)+VIS+CACHE CMP	CMP HANDLES (L+R) KIT+SCREW+ CAP SCREW CMP
14	89 533	KIT ETANCHEITE MP/CMP+VIS+CACHE VIS	MP/CMP WATERPROOFNESS KIT+SCREW+CAP SCREW
15	89 536	BOUTON VARIATEUR MP/CMP.+VIS+CACHE VIS	MP/CMP VARIATOR SWITCH+SCREW+CAP SCREW
16	89 546	KIT GRILLES CMP (x2)	CMP VENT COVERS KIT (x2)
17	89 548	Kit CONNECTEUR+VIS+CACHE VIS	CONNECTOR KIT+SCREW+CAP SCREW
18	89 662	OUTILLAGE DE DEMONTAGE MP/CMP	MP/CMP DISMOUNT TOOL
19	89 637	SUPPORT MURAL CMP	CMP WALL SUPPORT
20	89 623	VIS M4x95 CMP (x4)	CMP SCREW M4x95 (x4)
21	89 530	KIT BOUTON MP/CMP+VIS+CACHE VIS	MP/CMP KNOBS KIT +SCREW+CAP SCREW KIT
22	89 531	KIT LEVIER CDE MPC/CMP+VIS+CACHE VIS	MPC/CMP COMMAND ARM KIT+SCREW+CAP SCREW
23	89 532	KIT VIS POIG MP/CMP (x4)	MP/CMP HANDLE SCREW (x4)
24	89 608	VIROLE CMP 400 V.V.	CMP 400 VV FERRULE
25	89 612	VIROLE MOTEUR CMP	CMP MOTOR FERRULE
26	89 576	VENTILATEUR CMP	CMP VENTILATOR
27	89 570	CONDUIT VENTILATEUR CMP	CMP VENTILATOR PIPE
28	89 679	ROULEMENT MOTEUR CMP	CMP MOTOR BEARING
29	89 639	JOINT TORIQUE Ø2x1,5 (x4)	SEAL Ø2x1,5 (x4)
30	89 632	MOYEU D'ENTRAINEMENT MPC	MPC DRIVING HUB

Index	Désignation	Description
A	PLATINE	CIRCUIT BOARD
B	CABLE D'ALIMENTATION	POWER CORD
C	INDUIT	INDUCED CIRCUIT
D	CHARBONS (x2)	BRUSHES (x2)
M	MOTEUR	MOTOR

Machine	Voltage	A	B	C	D	M
34 261 / 34 261 A UK	240/50/1	89 751	89 539	89 759	89 575	89 994
34 260 / 34 260 A	230/50/1		89 538			

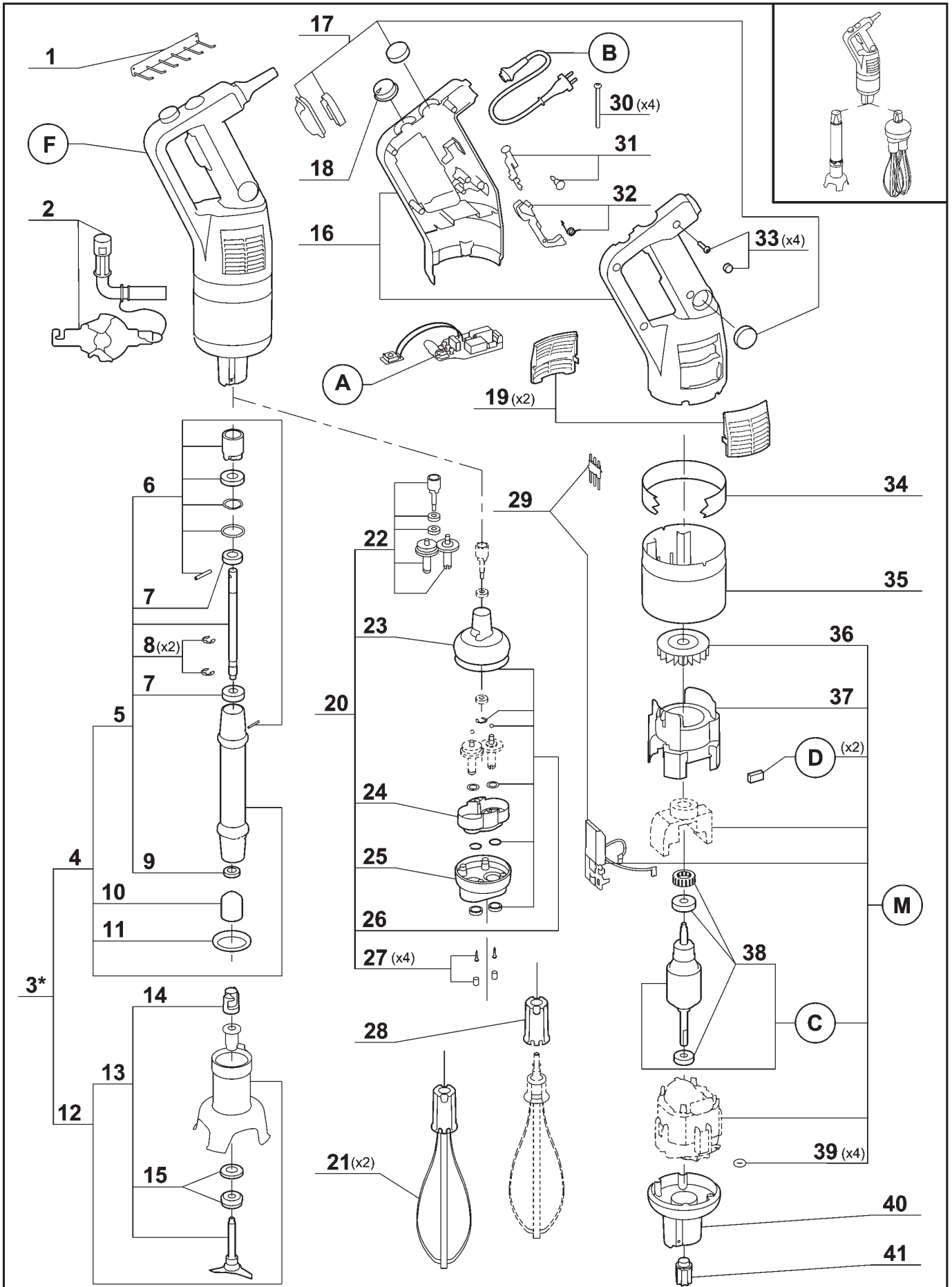

Index	Pièce / Part	Désignation	Description
1	89 630	SUPPORT MURAL MPC	MPC WALL SUPPORT
2	89 662	OUTIL DEMONTAGE MP/CMP	MP/CMP DISMOUNT TOOL
3	* 27 249	PIED CMPC 250 COMPLET	CMP 250 COMPLETE FOOT
4	89 656	PIED CMPC 250 EQUIPE	CMPC250 FOOT
5	89 811	ARBRE D'ENTRAINEMENT CMPC 250	CMPC 250 DRIVING SHAFT
6	89 643	KIT PIED MPC/CMP/CMPC	MPC/CMP/CMPC FOOT KIT
7	89 645	ROULEMENT INOX 608 2RS	STAINL ST BEAR 608 2RS
8	89 647	ANNEAU "E" (x2)	RING "E" (x2)
9	89 646	JOINT A LEVRE 8x18x5	SEAL 8x18x5
10	89 626	CAGE D'ENTRAINEMENT MP/CMP	MP/CMP DRIVING FRAME
11	89 628	JOINT DE PIED MP/CMP	FOOT SEAL
12	89 678	CLOCHE CMP EQUIPEE	CMP BELL COVER
13	89 676	COUTEAU CMP	CMP BLADE
14	89 627	MOYEU D'ENTRAINEMENT MP/CMP	MP/CMP DRIVING HUB
15	89 642	GARNITURE D'ETANCHEITE	SEAL RING
16	89 547	KIT POIGNEES (G+D)+VIS+CACHE CMP	CMP HANDLES (L+R) KIT+SCREW+ CAP SCREW CMP
17	89 533	KIT ETANCHEITE MP/CMP+VIS+CACHE VIS	MP/CMP WATERPROOFNESS KIT+SCREW+CAP SCREW
18	89 536	BOUTON VARIATEUR MP/CMP.+VIS+CACHE VIS	MP/CMP VARIATOR SWITCH+SCREW+CAP SCREW
19	89 546	KIT GRILLES CMP (x2)	CMP VENT COVERS KIT (x2)
20	89 651	BOITE FOUET CMP	CMP WHIP BOX
21	89 649	FOUETS CMP (x2)	CMP WHIPS (x2)
22	89 549	KIT PIGNONS + BAGUE + ROUL ^{ent} +VIS+CACHE-VIS B.F.	GEARS+RING+BEARING+SCREW+CAP SCREW KIT
23	89 379	COQUE SUP BF MP/CMP+VIS+CACHE VIS	MP/CMP BF UPPER BODY+SCREW+CAP SCREW
24	89 385	FLASQUE+VIS+CACHE-VIS	PLATE+SCREW+CAP SCREW
25	89 746	COQUE INF PLAST BF CMP	BF CMP LOWER BODY PLAS
26	89 545	KIT JOINT RONDELLE BF +VIS+CACHE VIS	BF SEAL WASHER KIT +SCREW+CAP SCREW KIT
27	89 389	VIS+CVIS BF MP CMP	BF SCREW+CAP SCREW
28	89 552	KIT EJECT FOUET MP/CMP	MP/CMP WHIP EJECTOR
29	89 548	KIT CONNECTION CMP+VIS+CACHE VIS	CMP CONNECTOR KIT+SCREW+CAP SCREW
30	89 623	VIS M4x95 CMP (x4)	CMP SCREW M4x95 (x4)
31	89 530	KIT BOUTON MP/CMP+VIS+CACHE VIS	MP/CMP KNOBS KIT +SCREW+CAP SCREW KIT
32	89 531	KIT LEVIER CDE MPC/CMP+VIS+CACHE VIS	MPC/CMP COMMAND ARM KIT+SCREW+CAP SCREW
33	89 532	KIT VIS POIG MP/CMP (x4)	MP/CMP HANDLE SCREW (x4)
34	89 609	VIROLE CMPC 250	CMPC 250 FERRULE
35	89 612	VIROLE MOTEUR CMP	CMP MOTOR FERRULE
36	89 576	VENTILATEUR CMP	CMP VENTILATOR
37	89 570	CONDUIT VENTILATEUR CMP	CMP VENTILATOR PIPE
38	89 679	ROULEMENT MOTEUR CMP	CMP MOTOR BEARING
39	89 639	JOINT TORIQUE Ø2x1,5 (x4)	SEAL Ø2x1,5 (x4)
40	89 641	CARTER ALU CMP	CMP ALUMINIUM CASING
41	89 661	MOYEU D'ENTRAINEMENT CMPC	CMPC DRIVING HUB

Index	Désignation	Description
A	PLATINE	CIRCUIT BOARD
B	CABLE D'ALIMENTATION	POWER CORD
C	INDUIT	INDUCED CIRCUIT
D	CHARBONS (x2)	BRUSHES (x2)
F	BLOC MOTEUR	BLOCK MOTOR
M	MOTEUR	MOTOR

Machine	Voltage	A	B	C	D	F	M
34 308 / 34 308 A Arabie	220/60/1	89 753	89 539	89 759	89 575	89 107	89 767
34 304 / 34 304 A			89 538			29 833	
34 300 / 34 300 A	230/50/1	89 751	89 542	89 759	89 575	29 819	89 767
34 306 / 34 306 A Suisse			89 405			29 837	
34 307 / 34 307 A Suede			89 539			29 763	
34 301 / 34 301 A UK	240/50/1	89 751	89 540	89 759	89 575	29 824	89 767
34 302 / 34 302 A Aust			89 540			29 828	
34 305 / 34 305 A	120/60/1	89 752	89 541	89 760	89 575	29 841	89 769
34 309 / 34 309 A Japon			89 522			29 791	

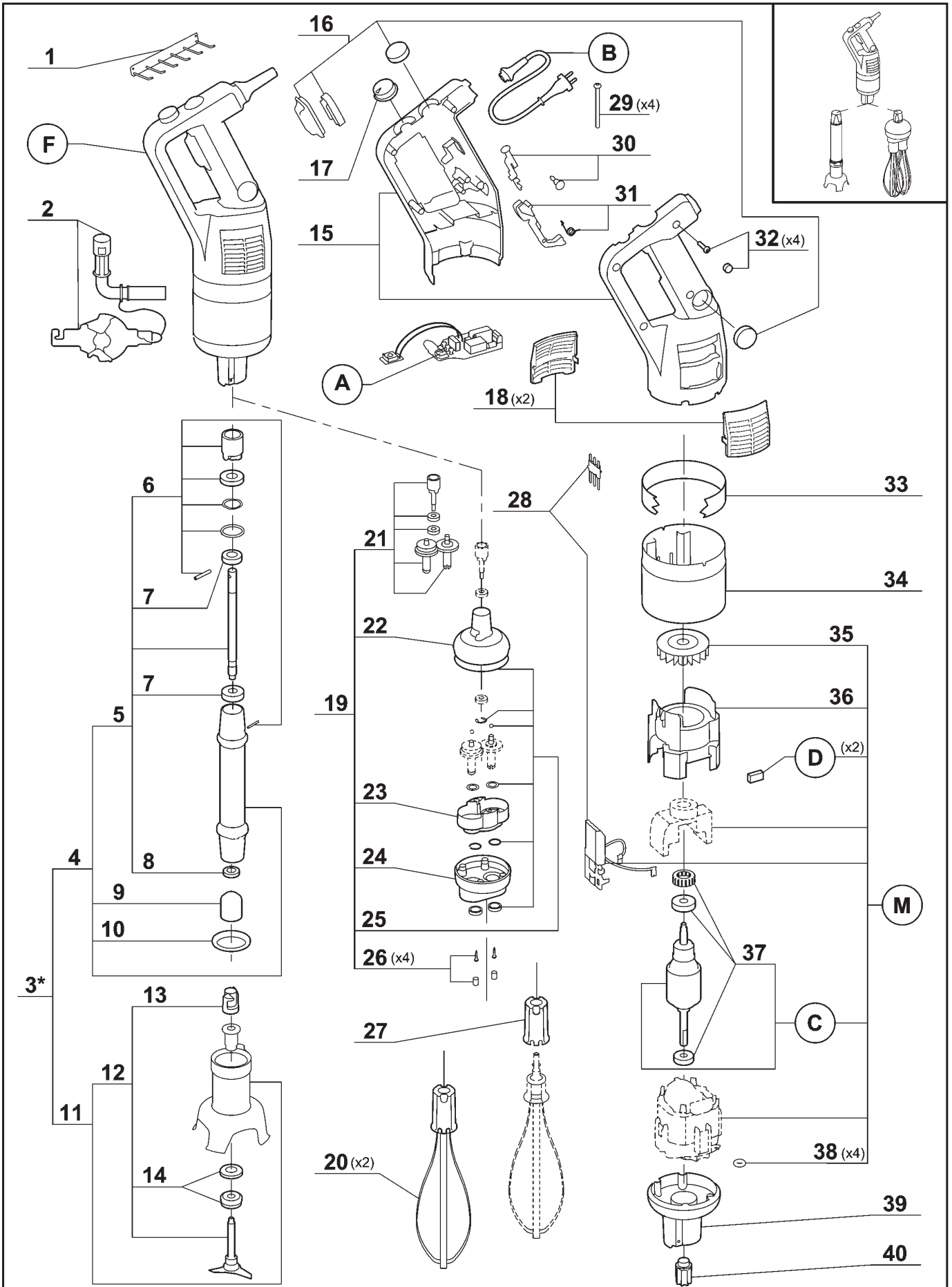

* Voir tarif machines / See export price list

Index	Pièce / Part	Désignation	Description
1	89 630	SUPPORT MURAL MPC	MPC WALL SUPPORT
2	89 662	OUTIL DEMONTAGE MP/CMP	MP/CMP DISMOUNT TOOL
3	* 27 250	PIED CMPC 300 COMPLET	CMPC 300 COMPLETE FOOT
4	89 657	PIED CMPC 300 EQUIPE	CMPC 300 FOOT
5	89 812	ARBRE D'ENTRAINEMENT CMPC 300	CMPC 250 DRIVING SHAFT
6	89 643	KIT PIED MPC/CMP/CMPC	MPC/CMP/CMPC FOOT KIT
7	89 645	ROULEMENT INOX 608 2RS	STAINL ST BEAR 608 2RS
8	89 646	JOINT A LEVRE 8x18x5	SEAL 8x18x5
9	89 626	CAGE D'ENTRAINEMENT MP/CMP	MP/CMP DRIVING FRAME
10	89 628	JOINT DE PIED MP/CMP	FOOT SEAL
11	89 678	CLOCHE CMP EQUIPEE	CMP BELL COVER
12	89 676	COUTEAU CMP	CMP BLADE
13	89 627	MOYEU D'ENTRAINEMENT MP/CMP	MP/CMP DRIVING HUB
14	89 642	GARNITURE D'ETANCHEITE	SEAL RING
15	89 547	KIT POIGNEES (G+D)+VIS+CACHE CMP	CMP HANDLES (L+R) KIT+SCREW+ CAP SCREW CMP
16	89 533	KIT ETANCHEITE MP/CMP+VIS+CACHE VIS	MP/CMP WATERPROOFNESS KIT+SCREW+CAP SCREW
17	89 536	BOUTON VARIATEUR MP/CMP.+VIS+CACHE VIS	MP/CMP VARIATOR SWITCH+SCREW+CAP SCREW
18	89 546	KIT GRILLES CMP (x2)	CMP VENT COVERS KIT (x2)
19	89 651	BOITE FOUET CMP	CMP WHIP BOX
20	89 649	FOUETS CMP (x2)	CMP WHIPS (x2)
21	89 549	KIT PIGNONS + BAGUE + ROUL ^{ent} +VIS+CACHE-VIS B.F.	GEARS+RING+BEARING+SCREW+CAP SCREW KIT
22	89 379	COQUE SUP BF MP/CMP+VIS+CACHE VIS	MP/CMP BF UPPER BODY+SCREW+CAP SCREW
23	89 385	FLASQUE+VIS+CACHE-VIS	PLATE+SCREW+CAP SCREW
24	89 746	COQUE INF PLAST BF CMP	BF CMP LOWER BODY PLAS
25	89 545	KIT JOINT RONDELLE BF +VIS+CACHE VIS	BF SEAL WASHER KIT +SCREW+CAP SCREW KIT
26	89 389	VIS+CVIS BF MP CMP	BF SCREW+CAP SCREW
27	89 552	KIT EJECT FOUET MP/CMP	MP/CMP WHIP EJECTOR
28	89 548	KIT CONNECTION CMP+VIS+CACHE VIS	CMP CONNECTOR KIT+SCREW+CAP SCREW
29	89 623	VIS M4x95 CMP (x4)	CMP SCREW M4x95 (x4)
30	89 530	KIT BOUTON MP/CMP+VIS+CACHE VIS	MP/CMP KNOBS KIT +SCREW+CAP SCREW KIT
31	89 531	KIT LEVIER CDE MPC/CMP+VIS+CACHE VIS	MPC/CMP COMMAND ARM KIT+SCREW+CAP SCREW
32	89 532	KIT VIS POIG MP/CMP (x4)	MP/CMP HANDLE SCREW (x4)
33	89 610	VIROLE CMPC 300	CMPC 300 FERRULE
34	89 612	VIROLE MOTEUR CMP	CMP MOTOR FERRULE
35	89 576	VENTILATEUR CMP	CMP VENTILATOR
36	89 570	CONDUIT VENTILATEUR CMP	CMP VENTILATOR PIPE
37	89 679	ROULEMENT MOTEUR CMP	CMP MOTOR BEARING
38	89 639	JOINT TORIQUE Ø2x1,5 (x4)	SEAL Ø2x1,5 (x4)
39	89 641	CARTER ALU CMP	CMP ALUMINIUM CASING
40	89 661	MOYEU D'ENTRAINEMENT CMPC	CMPC DRIVING HUB

Index	Désignation	Description
A	PLATINE	CIRCUIT BOARD
B	CABLE D'ALIMENTATION	POWER CORD
C	INDUIT	INDUCED CIRCUIT
D	CHARBONS (x2)	BRUSHES (x2)
F	BLOC MOTEUR	BLOCK MOTOR
M	MOTEUR	MOTOR

Machine	Voltage	A	B	C	D	F	M
34 318 / 34 318 A Arabie	220/60/1	89 753	89 539	89 759	89 575	89 108	89 761
34 314 / 34 314 A			89 538			29 834	
34 310 / 34 310 A	230/50/1	89 751	89 542			29 820	
34 316 / 34 316 A Suisse			89 539			29 838	
34 311 / 34 311 A UK			89 540			29 825	
34 322 / 34 322 A Aust	240/50/1	89 752	89 541			89 760	
34 315 / 34 315 A			89 522	29 792			
34 319 / 34 319 A Japon							

CMP250 V.V. - CMP300 V.V. - CMP350 V.V. - CMP400 V.V. - CMP250 Combi - CMP300 Combi

120V/60Hz - 220V/60Hz - 230V/50Hz - 240V/50Hz 1~

SCHEMA ELECTRIQUE

ELECTRIC DIAGRAM

ELEKTRISCHES SCHALTBILD

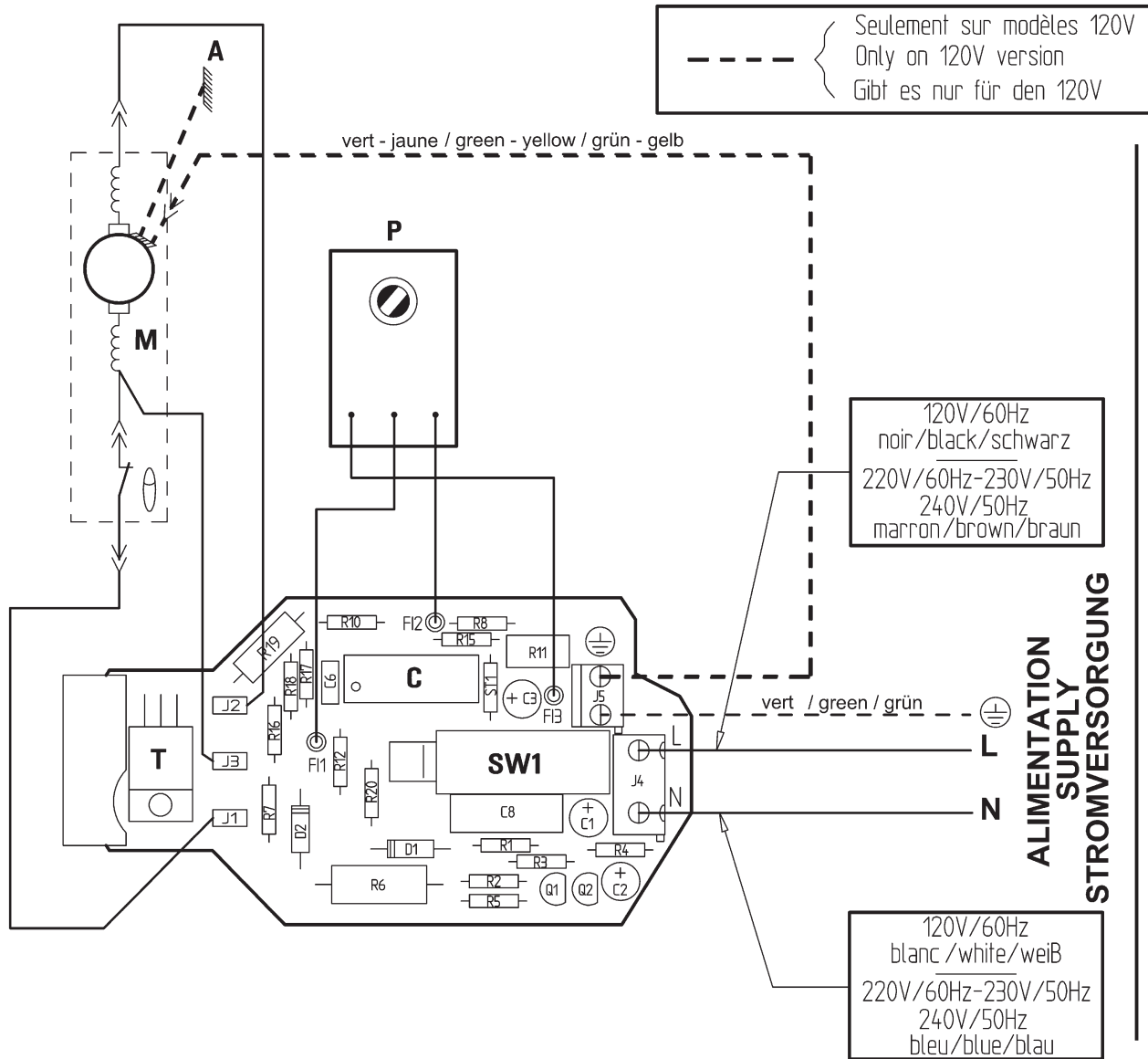

	Français	English	Deutsch
A	Capot aluminium	Aluminium housing	Aluminiumhaube
C	Unité de contrôle	Control unit	Kontrolleinheit
M	Moteur	Motor	Motor
P	Potentiomètre	Potentiometer	Potentiometer
SW1	Interrupteur marche/arrêt	On/off switch	Betriebsschalter/Stopschalter
T	Triac	Triac	Triac
\emptyset	Protecteur thermique	Thermal protector	Thermischschutz

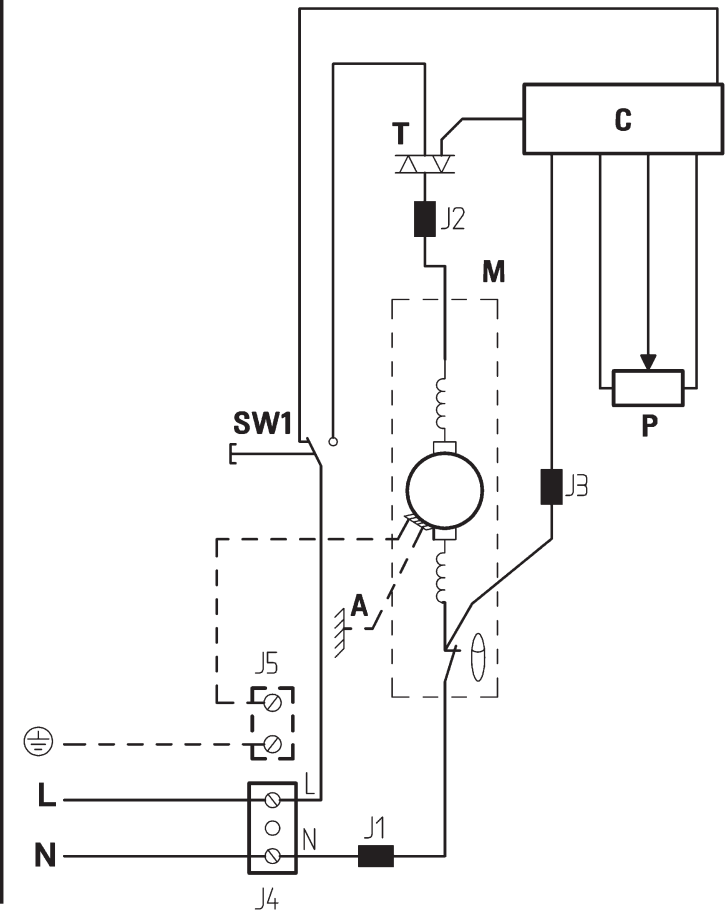



robot coupe®

**Head Office, French,
Export and Marketing Department:**
48, rue des Vignerons
94305 Vincennes Cedex- France
Tel.: 01 43 98 88 15 - Fax: 01 43 74 36 26
Email: international@robot-coupe.com

Delegación comercial en España:
Riera Figuera Major, 13-15 baix
08304 Mataró (Barcelona)
Tel.: (93) 741 10 23 - Fax: (93) 741 12 73
Email: robot-coupe@robot-coupe.e.telefonica.net

Service Clients Belgique
26, Rue des Hayettes
6540 Mont Sainte-Geneviève
Tél. : (071) 59 32 62
Fax : (071) 59 36 04
Email : info@robot-coupe.be

Robot-Coupe Italia / MaxMec
Via Stelloni Levante 24/a
40012 Calderara di Reno (BO)
Tel: 051726810 - Fax: 051726812
Email: info@maxmec.it

www.robot-coupe.com