



## E600 Rise and Fall Grill



### Short Form Specification

Unit to be Falcon F900 Series rise and fall grill that may be wall-mounted or installed upon a table.

Unit will be operated manually or by programmable function controlled by touch screen.

Unit will have a dish detection function and the grill canopy can be adjusted in height to be in the proximity of the food being cooked.

Exterior panels are stainless steel.

### Key Features

- Instant heat delivered by powerful infra-red elements
- Automatic plate-sensing technology saves energy
- 1/1 gastronorm compatible
- One touch operation
- Manual or programmable mode
- IPX 3 water resistance certification
- One touch operation
- Manual or programmable mode

### Accessories

- Bench legs



## E600 Rise and Fall Grill

### Model Dimensions (mm)

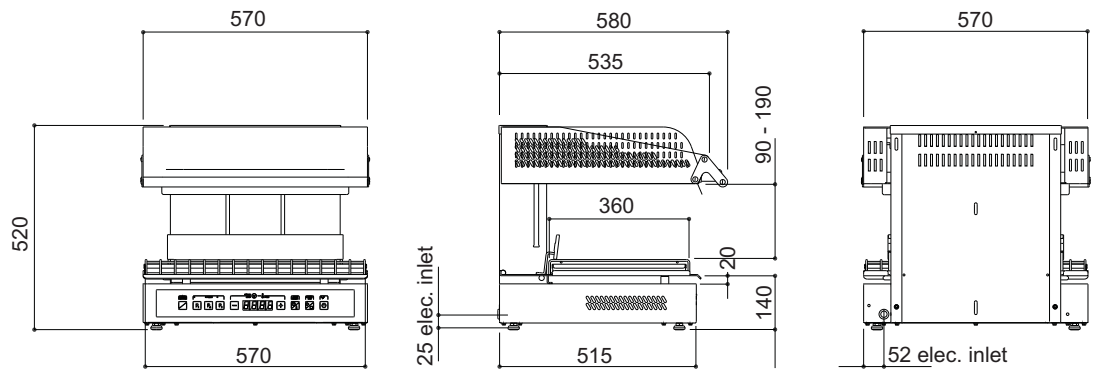

Cooking Area is 560 x 360

### Specification Details

Electrical rating (kW)	4.2
Electrical supply voltage (V)	400V 3N~ 50/60z or 230V ~
Required electrical supply - 400V 3N~(A)	32
Phase split - 400V 3N~ (A)	L1: 6.52 / L2: 6.52 / L3: 6.52
Phase split - 230V~ (A)	19.56
Weight (kg)	69
Packed weight (kg)	75
Packed dimensions (mm)	680 (w) x 650 (d) x 730 (h)

#### **Installation Note:**

Please consult local legislation with regard to installation of cooking equipment.