

COMBINATION OVENS
CHEFMATE SERIES



Hobart Cooking Solutions
Southgate Way
Orton Southgate
Peterborough
PE2 6GN
Telephone - 0844 225 1999
www.hobartuk.com/cooking

Chefmate Basic Touch Electric 4 Grid Combination Oven

HCSCME4

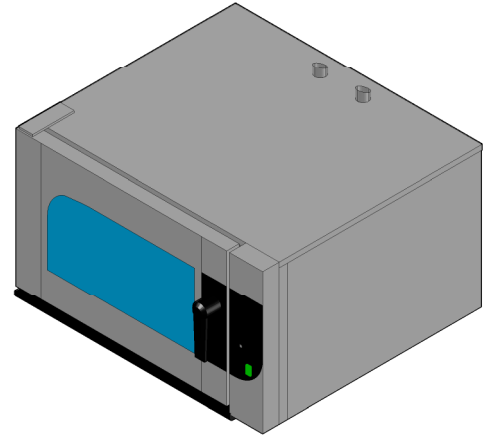
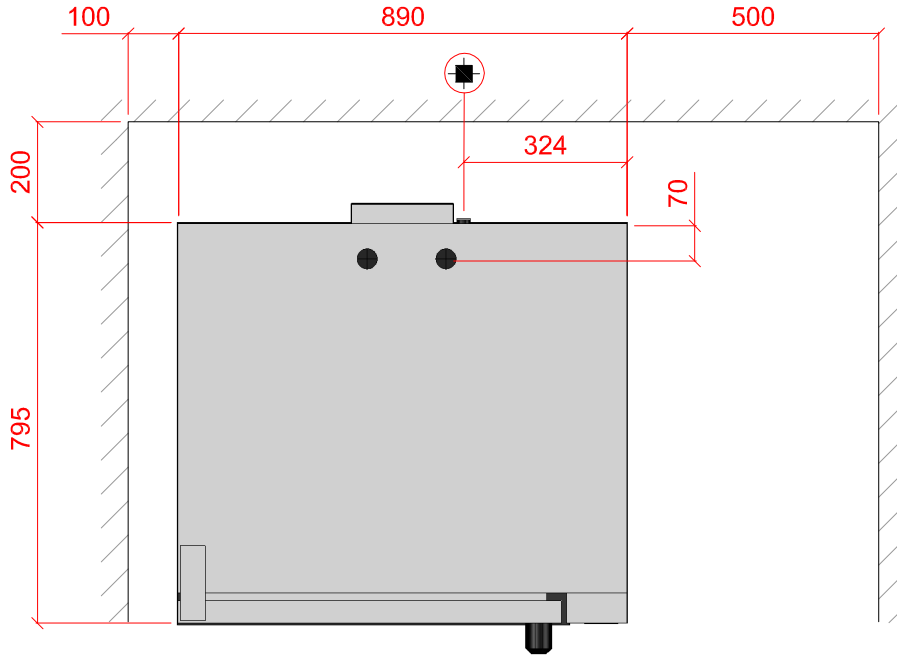

Plan View Showing
Suggested Install/Service
access Clearances

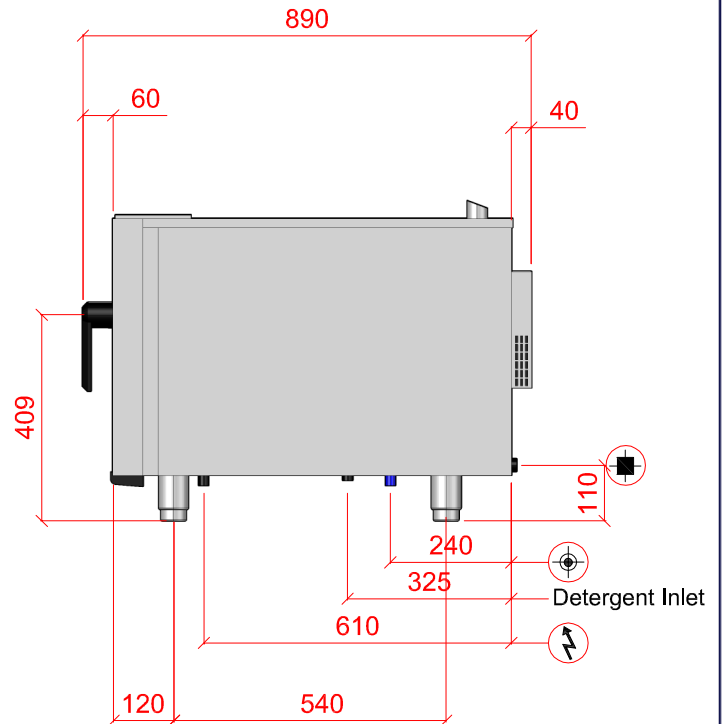
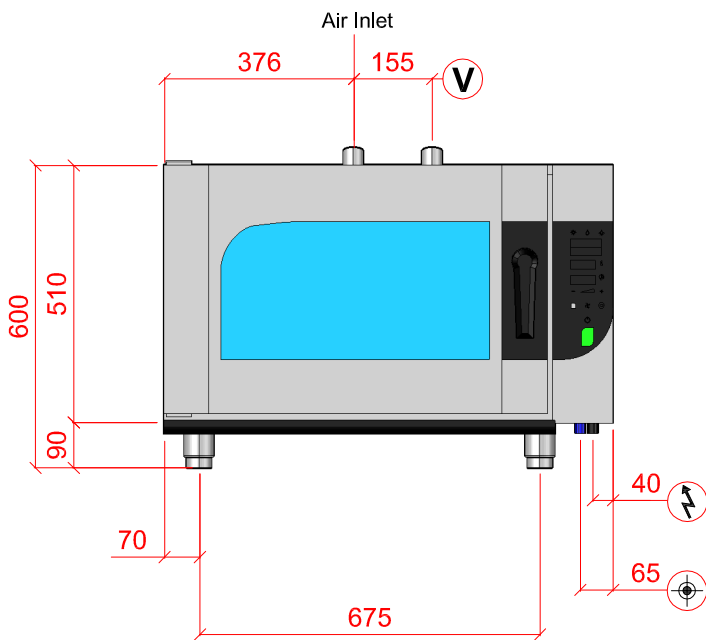

Note
The HCSCME4 is not compatible with the accessory External Core Probe.

Temperature Cooking Range = 40 to 250°C

Water	Drain	Electric Loading	Vent Outlet
3/4" B.S.P. POTABLE WATER, 2.0 TO 4.0 BAR MAX PRESSURE. MAX TEMP: 30°C (2 TO 5° CLARK MAX) 5°e, 70ppm - MAX WATER HARDNESS PERMITTED. WATER QUALITY: MAXIMUM CONCENTRATION OF CHLORIDE Cl:100mg/l AND CHLORINE Cl₂:0.2mg/l	1" DRAIN CONDENSATE TEMPERATURE APPROX 98°C SPECIAL NOTE: DO NOT INSTALL UNIT CLOSE TO HOT APPLIANCES ON CONTROL PANEL SIDE UNIT SHOULD BE LOCATED UNDER A VENTILATION CANOPY. RECOMMENDED TO BE USED WITH A WATER TREATMENT SYSTEM. WEIGHT 100kg net	6.0kW 400/50/3 + N + E FUSE AT 8.7 AMPS/PHASE	Ø40mm RECOMMENDED EXTRACTION FLOW 390m ³ /hour
RIGHT TO MAKE NECESSARY CHANGES IS RESERVED			

ELECTRICAL CONNECTION
 WATER CONNECTION
 DRAIN
 VENT OUTLET

PLOT SCALE: 1:15