



Blender

Instruction manual



Model • Modèle • Modell • Modello • Modelo • Malli:
CR836/DR825

Safety Tips

- Position on a flat, stable surface.
- A service agent/qualified technician should carry out installation and any repairs if required. Do not remove any components on this product.
- Consult Local and National Standards to comply with the following:
 - Health and Safety at Work Legislation
 - BS EN Codes of Practice
 - Fire Precautions
 - IEE Wiring Regulations
 - Building Regulations
- DO NOT use jet/pressure washers to clean the appliance.
- DO NOT immerse the appliance in water.
- This appliance is only used for blending food. Do not use the appliance for anything other than its intended use.
- Always switch off and disconnect the power supply to the appliance when not in use.
- Not suitable for outdoor use..
- Keep all packaging away from children. Dispose of the packaging in accordance to the regulations of local authorities.
- If the power cord is damaged, it must be replaced by an BUFFALO agent or a recommended qualified technician in order to avoid a hazard.
- This appliance is not intended for use by persons (including children) with reduced physical, sensory or mental capabilities, or lack of experience and knowledge, unless they have been given supervision or instruction concerning the use of the appliance by a person responsible for their safety.
- Children should be supervised to ensure that they do not play with the appliance.

- Do not let cord hang over edge of table or counter, or touch hot surfaces.
- Keep hands and utensils out of the jug while motor is running to prevent severe personal injury and / or damage to the blender.
- **Blade is sharp – handle carefully.**
- Never try to remove blade while jug is sitting on the blender base.
- Do not operate with loose or damaged blades.
- Do not place jug on to base with On/Off switch in the On position.
- Always operate with lid in place.
- Do Not blend Hot Liquids.
- Do not leave blender unattended while in use.
- Buffalo recommend that this appliance is PAT tested on an annual basis to ensure the product remains safe.

Introduction

Please take a few moments to carefully read through this manual. Correct maintenance and operation of this machine will provide the best possible performance from your BUFFALO product.

Product Description

CR836 - Buffalo Blender - 2.5L Jug

DR825 - Buffalo Blender - 2.5L Jug with Sound Enclosure

Pack Contents

The following is included:

- BUFFALO Blender
- Blender Jug, lid and lid plug
- Food pusher
- Instruction manual

BUFFALO prides itself on quality and service, ensuring that at the time of packaging the contents are supplied fully functional and free of damage.

Should you find any damage as a result of transit, please contact your BUFFALO dealer immediately.

Operation

Model: CR836

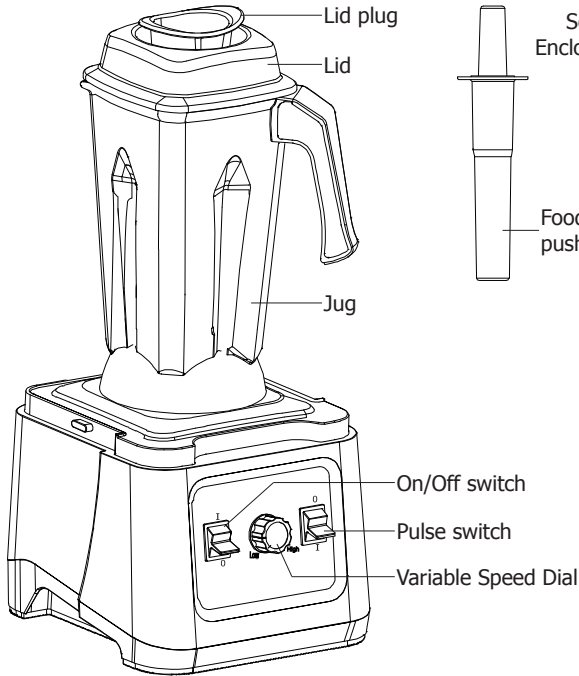

Model: DR825

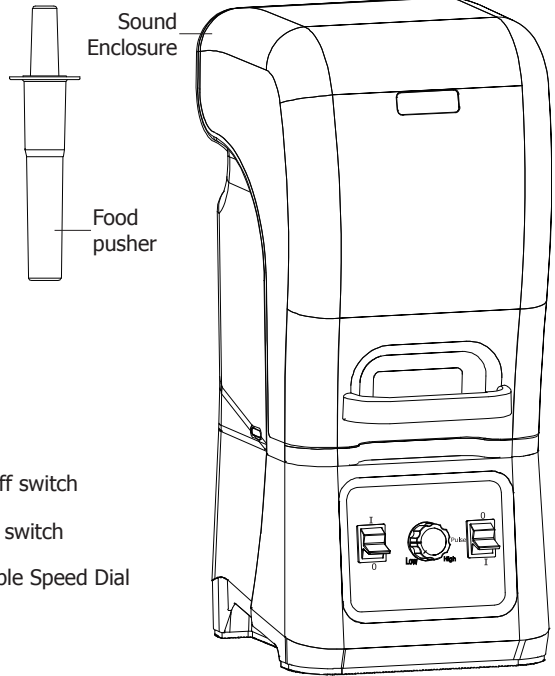

Controls

- On/Off switch: Up for On (**I**), down for Off (**0**)
- Variable Speed Dial: Allows continual adjustment of speed from **low** to **high**
- Pulse Switch: Down to pulse at high speed

Blending



Before use, ensure to

- **Clean all removable parts thoroughly.**
- **Turn off On/Off switch (0 position).**

1. Plug in Blender.
2. Place ingredients into blender.
3. Secure the lid and lid plug (**Note: Always operate with the lid secured**).
4. Locate jug on to body of blender.
5. Select speed using variable speed dial.
6. Turn on blender using On/Off switch.
7. **Using the pulse function:** Set the Pulse switch to **I** position and hold to start pulse function. Release to stop.



Note: When blending dry ingredients best results will be obtained by cutting ingredients into small pieces and adding to the blender through the hole in the lid when motor is running.



Note: Before removing jug, ensure to turn off blender using On/Off switch and let the motor come to a complete stop.

Cleaning, Care & Maintenance

- Always disconnect from power supply before cleaning.
- Always allow to cool before cleaning.
- Let the motor come to a complete stop before removing the jug.
- The jug is NOT dishwasher proof!
- Use warm, soapy water and a damp cloth to clean the jug.



Warning: Blade is sharp - handle with care.

- Dry thoroughly after cleaning.
- A BUFFALO dealer or qualified technician should carry out repairs if required.



Warning: Do not allow any water to spill into the body of the appliance when cleaning.

Troubleshooting

Fault	Probable Cause	Solution
The unit is not working	The unit is not switched on	Check the unit is plugged in correctly and switched on
	Plug and lead are damaged	Call BUFFALO agent or qualified Technician
	Fuse in the plug has blown	Replace the plug fuse
	Power supply	Check power supply
	Internal wiring fault	Call BUFFALO agent or qualified technician
	Jug incorrectly located on body of appliance	Relocate Jug

Technical Specifications

Model	Voltage	Power	Current	Jug Capacity	Dimensions h x w x d mm	Weight
CR836	220-240V 50/60Hz	1680W	8A	2.5L	305 x 450 x 340	5.9kg
DR825	220-240V 50/60Hz	1680W	8A	2.5L	600 x 325 x 305	8.9kg

Electrical Wiring

This appliance is supplied with a 3 pin, moulded, BS1363 plug and lead, with a 13 amp fuse as standard.

The plug is to be connected to a suitable mains socket.

This appliance is wired as follows:

- Live wire (coloured brown) to terminal marked L
- Neutral wire (coloured blue) to terminal marked N
- Earth wire (coloured green/yellow) to terminal marked E

This appliance must be earthed.



If in doubt consult a qualified electrician.

Electrical isolation points must be kept clear of any obstructions. In the event of any emergency disconnection being required they must be readily accessible.

Compliance

The WEEE logo on this product or its documentation indicates that the product must not be disposed of as household waste. To help prevent possible harm to human health and/or the environment, the product must be disposed of in an approved and environmentally safe recycling process. For further information on how to dispose of this product correctly, contact the product supplier, or the local authority responsible for waste disposal in your area.



BUFFALO parts have undergone strict product testing in order to comply with regulatory standards and specifications set by international, independent, and federal authorities.



BUFFALO products have been approved to carry the following symbol:

All rights reserved. No part of these instructions may be produced or transmitted in any form or by any means, electronic, mechanical, photocopying, recording or otherwise, without the prior written permission of BUFFALO.

Every effort is made to ensure all details are correct at the time of going to press, however, BUFFALO reserve the right to change specifications without notice.

DECLARATION OF CONFORMITY

• Conformiteitsverklaring • Déclaration de conformité • Konformitätserklärung • Dichiarazione di conformità •
• Declaración de conformidad • Declaração de conformidade

Equipment Type • Uitrustingstype • Type d'équipement • Gerätetyp •
Tipo di apparecchiatura • Tipo de equipo • Tipo de equipamento

Blender - 2.5Ltr Jug
Blender - 2.5Ltr Jug - with Sound Enclosure

Model • Modèle • Modell • Modello • Modelo • Malli

CR836
DR825

Application of Council Directives(s)

Toepassing van Europese Richtlijn(en) • Application de la/des
directive(s) du Conseil • Anwendbare EU-Richtlinie(n) • Applicazione
delle Direttive • Aplicação de la(s) directiva(s) del consejo • Aplicação
de directiva(s) do Conselho

Machinery Directive 2006/42/EC
EN 60204-1: 2006 +A1:2009/AC2010
EN ISO 12100:2010
EN 12852:2001 +A1:2010

**Electro-Magnetic Compatibility (EMC) Directive
2014/30/EU**

EN 55014-1: 2006 +A1:2009+ A2:2011
EN 61000-3-2:2014
EN 61000-3-3:2013
EN 55014-2:2015

**Restriction of Hazardous Substances Directive
(RoHS) 2011/65/EU**

Buffalo

Producer Name • Naam fabrikant • Nom du producteur • Name des
Herstellers • Nome del produttore • Nombre del fabricante • Nome do
fabricante

**Fourth Way,
Avonmouth,
Bristol,
BS11 8TB
United Kingdom**

Producer Address • Adres fabrikant • Adresse du producteur •
Anschrift des Herstellers • Indirizzo del produttore • Dirección del
fabricante • Endereço do fabricante

I, the undersigned, hereby declare that the equipment specified above conforms to the above Directive(s) and Standard(s).
Ik, de ondergetekende, verklaar hierbij dat de hierboven gespecificeerde uitrusting goedgekeurd is volgens de bovenstaande
Richtlijn(en) en Standaard(en).

Je soussigné, confirme la conformité de l'équipement cité dans la présente à la / aux Directive(s) et Norme(s) ci-dessus
Ich, der/die Unterzeichnende, erkläre hiermit, dass das oben angegebene Gerät der/den oben angeführten Richtlinie(n) und Norm(en)
entspricht.

Il sottoscritto dichiara che l'apparecchiatura di sopra specificata è conforme alle Direttive e agli Standard sopra riportati.

El abajo firmante declara por la presente que el equipo arriba especificado está en conformidad con la(s) directiva(s) y estándar(es)
arriba mencionadas.

Eu, o abaixo-assinado, declaro que o equipamento anteriormente especificado está em conformidade com a(s) anterior(es) Directiva(s)
e Norma(s)

Date • Data • Date • Datum • Data • Fecha • Data

27th December 2017

Signature • Handtekening • Signature • Unterschrift
Firma • Firma • Assinatura



Ashley Hooper

Full Name • Volledige naam • Nom et prénom • Vollständiger Name •
Nome completo • Nombre completo • Nome por extenso

Position • Functie • Fonction • Position • Qualifica • Posición • Função

Technical & Quality Manager



<http://www.buffalo-appliances.com/> 

CR836_DR825_ML_A5_v1_171228