



C6A/75B - Seal 650 Series  
Counter-top Curved Front  
Ambient Merchandiser -  
Back-Service - W 750  
mm - 0.02 kW

Display your pastries, breads and cakes with pride with the Seal 650 Range Curved Front Ambient Merchandiser.

- ✓ Understated elegant curved design with extruded aluminium frames and metallic silver finish, which enhances display without detracting from the contents
- ✓ Sleek design and chrome plated rod shelves are attractive and easy to clean
- ✓ All-round visibility to maximise food sales potential
- ✓ Suitable for self-service applications
- ✓ Provides daylight balanced illumination, which lights up the units interior and spotlights each product
- ✓ This products design ensures a smooth fit alongside other refrigerated, ambient and heated units

**Specifications**

**Summary**

<b>Range Name</b>	Seal
<b>Power Type</b>	Electric
<b>Unit Type</b>	Counter-top
<b>Available in UK Only</b>	No
<b>UK Warranty</b>	2 Years Parts and Labour Warranty
<b>Export Warranty</b>	Contact your local dealer
<b>GTIN Code</b>	5056105103813

**Power and Performance**

<b>Total Power kW</b>	0.02
<b>IP Rating</b>	IP33

**Key Specifications**

<b>Number of Shelves included</b>	2
<b>Number of Shelf Positions</b>	2
<b>Service Type</b>	Back service
<b>Rack Type</b>	Static
<b>Type of Lighting</b>	Fluorescent

**Weights and Dimensions**

<b>Unit Height (External) mm</b>	755
<b>Unit Width (External) mm</b>	750
<b>Unit Depth (External) mm</b>	650
<b>Shelf Dimensions Width mm</b>	650
<b>Shelf Dimensions Depth mm</b>	525
<b>Net Weight Kg</b>	45

**Supply Connections**

<b>Requires Installation</b>	No
<b>Requires Electrical Supply</b>	Yes
<b>UK 3 Pin Plug</b>	Yes
<b>Requires Hardwiring</b>	No
<b>Electrical Supply Rating Watts</b>	20
<b>Single Phase Amps</b>	<1.0
<b>Single Phase Voltage</b>	230

**Shipping**

<b>Packed Weight Kg</b>	59
<b>Packed Height cm</b>	89
<b>Packed Width cm</b>	100
<b>Packed Depth cm</b>	85

**Technical Picture**

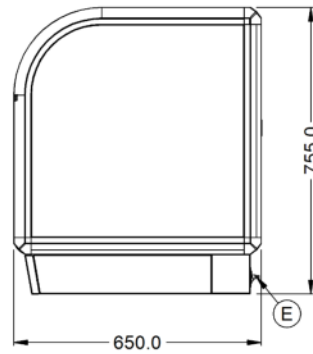
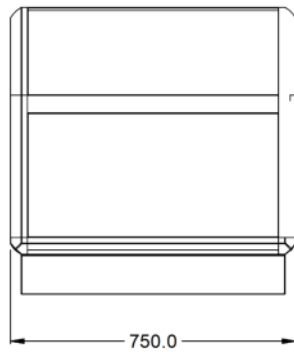
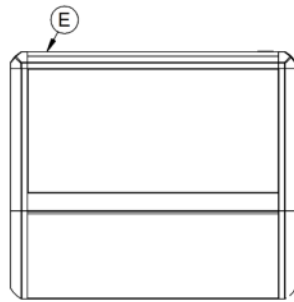

**Lincat Limited**

Whisby Road,  
Lincoln, LN6 3QZ,  
United Kingdom

**Company No:** 2175448

A member company of



**Customer Care**

**Tel:** +44 1522 875500  
**Email:** care@lincat.co.uk

**Export Customers**

**Tel:** +44 1522 503250  
**Email:** export@lincat.co.uk

**Opening Hours**

**Monday – Friday:**  
8.30am – 5pm