



# DISHWASHER P-50B 230/50/1 DD (WITH DRAIN PUMP)

500x500mm. racks. Max. loading height: 330mm.

P/N 1302083



## FEATURES AND BENEFITS

- ✓ For washing glasses, cups, cutlery and small plates.
- ✓ Washing with double system of rotating dispersers (top and bottom).
- ✓ 1 wash cycle.
- ✓ Manufactured from catering grade AISI 304 2B stainless steel and incorporating top quality components.
- ✓ Double skinned door with high efficiency seal, ensuring thermal and acoustic insulation. Magnetic door micro-switch.
- ✓ Precision positioned water jets guarantee optimum washing result for even the most stubbornly stained glasses. Easy to assemble, boltless rinse spray arms.
- ✓ Inside of the machine with rounded finished: absence of angles avoiding the accumulation of dirt.
- ✓ Automatic detergent and rinse aid dosing equipment.
- ✓ Sammic ware washers are designed for easy and fast on-site maintenance.
- ✓ 100% tested.

### PLEASE NOTE:

Boiler: 2.800W / Total power: 3.170W up to March 2017

Boiler: 2.500W / Total power: 2.870W from March 2017

## INCLUDES

- ✓ Rinse aid doser. valve.
- ✓ Variable detergent dosing equipment. ✓ 1 open basket.
- ✓ Drain pump with non-return ✓ 1 mixed basket.
- ✓ 1 small cutlery basket.

## SALES DESCRIPTION

Professional Washing with Total Guarantee.

- ✓ User-friendly.
- ✓ Optimal washing results.
- ✓ Sturdy and reliable.
- ✓ Stainless steel, sturdy and resistant washing arms. Don't get damaged because of chemical corrosion.
- ✓ 2.5 kW tank element: optimal recovery time.



[www.sammic.co.uk](http://www.sammic.co.uk)

Food Service Equipment Manufacturer

Unit 2, Trevanah Road  
Troon Industrial Park  
LE4 9LS - Leicester

[uksales@sammic.com](mailto:uksales@sammic.com)  
Tel.: +44 0116 246 1900



Project

Date

Item

Qty

Approved

WARE WASHING  
COMMERCIAL DISHWASHERS

product sheet  
updated 07/05/2018



# DISHWASHER P-50B 230/50/1 DD (WITH DRAIN PUMP)

500x500mm. racks. Max. loading height: 330mm.



P/N 1302083

## SPECIFICATIONS

Basket dimensions: 500 mm x 500 mm

Maximum glass height: 330 mm

Cycle duration: 180 "

Production baskets/hour: 20

Wash temperature: 0 °C - 65 °C

Rinse temperature: 0 °C - 90 °C

✓ Boiler capacity: 4.5 l

✓ Wash tank capacity: 26 l

✓ Water consumption/cycle: 3 l

✓ Electrical supply: 230 V / 50 Hz / 1 ~ (12.6 A)

✓

## Loading

✓ Pump: 370 W / 0.5 Hp

✓ Tank: 2500 W

✓ Boiler: 2800 W

✓ Total loading: 3170 W

✓

## External dimensions (WxDxH)

✓ Width: 600 mm

✓ Depth: 630 mm

✓ Height: 835 mm

Net weight: 58.5 Kg

## Crated dimensions

640 x 695 x 960 mm

Gross weight: 65 Kg.

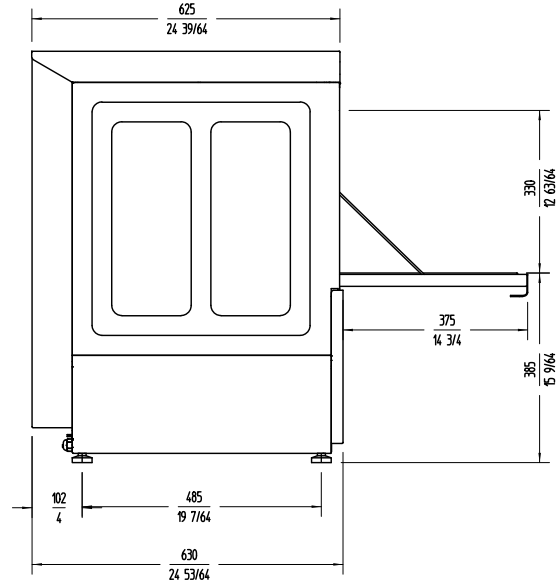
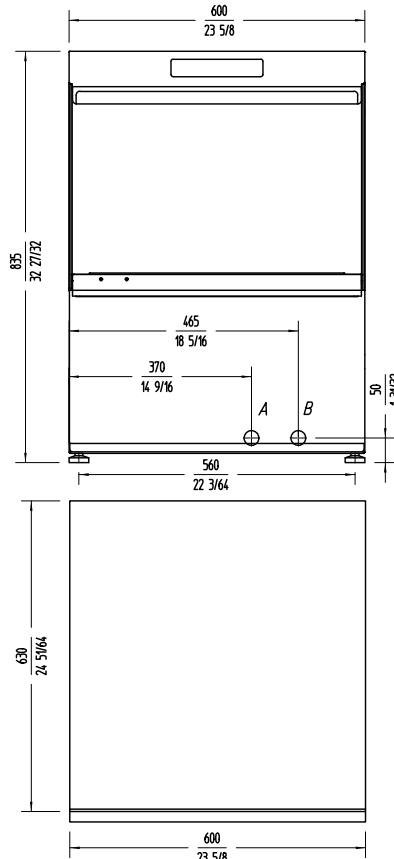

WARE WASHING  
COMMERCIAL DISHWASHERS



[www.sammic.co.uk](http://www.sammic.co.uk)

Food Service Equipment Manufacturer

Unit 2, Trevanah Road

Troon Industrial Park

LE4 9LS - Leicester

[uksales@sammic.com](mailto:uksales@sammic.com)

Tel.: +44 0116 246 1900



Project

Date

Item

Qty

Approved

product sheet  
updated 07/05/2018