



## Self-contained ice maker - Sprayer system Daily production up to 90 kg

Hotel	████████████████████
Restaurant	████████████████████
Fast food	████████████████████
Bar	████████████████████
Disco	████████████████████
Fish market	████████████████████
Supermarket	████████████████████
Medical & SPA	████████████████████
Industry	████████████████████

### ► Position n°



### ► Features & Plus

- Compact and crystal cube
- AISI 304 SS Scotch Brite finish
- Tropical class +43°C
- Adjustable Stainless Steel feet
- Removable and cleanable air filter
- Air or water cooling system
- Easy cleanable internal rounded surfaces
- HCFC-Free insulated storage
- RoHS Free
- Disappearing insulated door
- Electromechanical operation
- ON-OFF rocker switch
- Standard and special voltages



AISI 304 SS Scotch Brite finish



Adjustable Stainless Steel feet



Removable and cleanable air filter



Disappearing insulated door

### ► Available ice cube size

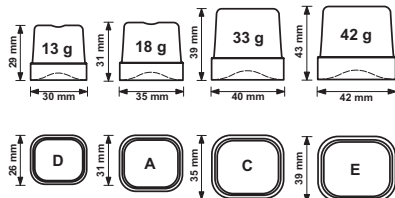

### ► Prod. 24h

Air temp.	Water temp.		kg	lbs	
	10° C	50° F			
	7° C	45° F			
10° C	50° F	7° C	45° F	90	198
21° C	70° F	15° C	60° F	85	187

**2 Years Warranty**  
subject to limitations

### ► Certifications available for this model





Ice Cube

**CB 840**

**Self-contained ice maker - Sprayer system**  
Daily production up to 90 kg

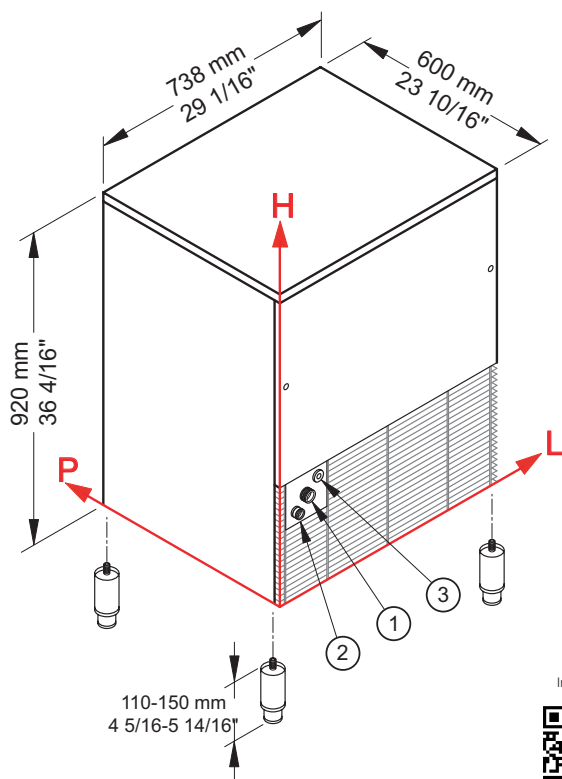
**► Working conditions**

- Location: **Indoor**

	Min	Max
Ambient temperature	+10° C / +50° F	+43° C / 110° F
Water temperature	+3° C / +37° F	+32° C / +90° F
Voltage	-10%	+10%
Water inlet pressure	1bar (14 psi)	6bar (84 psi)

**► Performances**

	Air temperature	Water temperature	Water temperature					
			7° C	45° F	15° C	60° F	21° C	70° F
	10° C	90 kg						
	50° F	198 lbs						
	21° C		85 kg					
	70° F			187 lbs				
	32° C				78 kg			
	90° F					172 lbs		

**► Connections**

All measures are referred to the rear bottom-left corner (L-H-Ø)

- ① Water in.: 116 mm / 4 9/16" - 285 mm / 11 4/16" - 3/4"      ② Water out.: 54 mm / 2 2/16" - 245 mm / 9 10/16" - 24 mm / 15/16"  
 ③ Electrical connections: 161 mm / 6 5/16" - 321 mm / 12 10/16"

**► Technical information**

Production in 24h	85 kg / 187 lbs
Store capacity, up to	40 kg / 88 lbs
Cooling system	A - W
Kind of cube	A-18g, C-33g, D-13g, E-42g
Refrigerant	R404A - R452A
Standard voltage	220-240 V ~ 50 Hz
Average power consumption	800 W
Fuse	10 A
Finish	AISI 304 stainless steel, scotch brite

Water consumption	A: 2,6 l/kg - 31,1 gal/100 lbs
	W: 14,4 l/kg - 172,6 gal/100 lbs
Sizes (L-P-H mm)	738 - 600 - 920
(L-P-H in)	29 1/16 - 23 10/16 - 36 4/16
Sizes with pack (L-P-H mm)	780 - 640 - 1085
(L-P-H in)	30 11/16 - 25 3/16 - 42 11/16
Net weight	86 kg / 190 lbs
Gross weight	98 kg / 216 lbs

All the technical information need to be considered at the following conditions:

- Standard Cube (18 g)
- Ambient temperature +21° C
- Water temperature +15° C
- Average power consumption at +43° C (standard voltage)

Models and specifications are subject to change without notice

Rev. 04 - Issued September 2019



[www.bremaice.it](http://www.bremaice.it)  
info@bremaice.it

Bim + Data  
download

