

# Venus Ice Cream Display

**VENUS ELEGANTE 36**



Removable scoop wash tub for easy cleaning (not plumbed)



High capacity under storage (holds Product in Reserve)

Standard graphics as shown in picture; Customised graphics available (P.O.A)

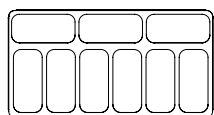
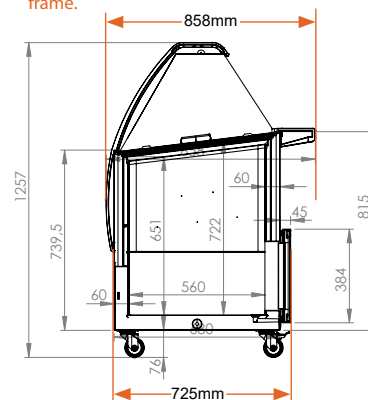
Depth is 858mm when fully assembled.  
Depth is 725mm after removing the anthracite frame.



**VENUS 36**  
9 Napoli containers on display  
(Not supplied)

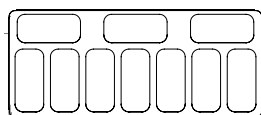

**VENUS 46**  
10 Napoli containers on display  
(Not supplied)

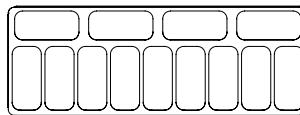

**VENUS 56**  
13 Napoli containers on display  
(Not supplied)

## FEATURES

- White finish with anthracite frame
- Sliding glass lid over display area enables you to keep the ice cream overnight
- Accepts 5L Napoli containers (not supplied)
- Castors as standard
- LED lighting: internal and in graphics panel
- Curved glass
- Anodised aluminium top profile
- High capacity under storage
- Skin evaporator to reduce energy consumption compared to forced air version

## TECHNICAL SPECIFICATIONS

Controller:	Manual thermostat with digital temperature display
Cooling:	Static
Defrost:	Manual
Refrigerant:	R290
Climate Class:	4
Temperature Range:	-15°C ~ -22°C
Power Supply:	13amp

MODEL	DISPLAY CAPACITY*	STORAGE CAPACITY*	GROSS CAPACITY	EXT. DIMENSIONS (H x W x D mm)	POWER CONSUMPTION	DECIBELS	WEIGHT (kg)	RRP
VENUS ELEGANTE 36	9	10	354L	1257 x 1202 x 858	227W	48dBA	112	
VENUS ELEGANTE 46	10	14	454L	1257 x 1457 x 858	270W	48dBA	133	
VENUS ELEGANTE 56	13	18	557L	1257 x 1672 x 858	276W	50dBA	150	
GN-NAPOLI	-	-	-	-	-	-	-	

\* Capacity for 5L Napoli containers

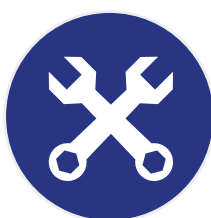

Glass structure requires assembly on site.

