

NE-17521

1700 Watt* Commercial Microwave Oven



Technical Specifications

Power source:	208/230-240V, 60Hz, Single phase
Receptacle required:	NEMA 6-20R 
Frequency:	2,450MHz
Required power:	208: (16.6A); 230-240: (15.3A) Auto Switch
Output*:	1700 Watts
Outer dimensions:	16 5/8" w x 20" d x 13 3/16" h
Cavity dimensions:	13" w x 12" d x 6 7/8" h
Net weight:	68 lbs.
Shipping weight:	73 lbs.
Shipping box size:	19 15/16" w x 24 1/8" d x 16 7/8" h, 4.7 ft ³
Warranty:	1 Year Parts, Labor and Travel/Shipping

To specify a Panasonic Commercial Microwave Oven:

The NE-17521 Commercial Microwave Oven meets or exceeds all safety performance and sanitation standards set for commercial food service microwave ovens by: UL, HHS, FCC and NSF.

Plus, oven shall have output power 1700 Watts*, Independently controlled top and bottom energy feed, Grab & Go door handle, Automatic Voltage Selector, patented Safety Door Seal System, 90 programmable memory pads, 3-stage cooking, 15 power levels, LCD digital display w/countdown, energy efficient LED cavity lighting, programmable lock, self-diagnostics, oven cycle counter, stackable, video training and Chef/Test Kitchen technical support.

** I.E.C. 705-88 Test Procedure. Specifications subject to change without notice.*

Receptacle Required

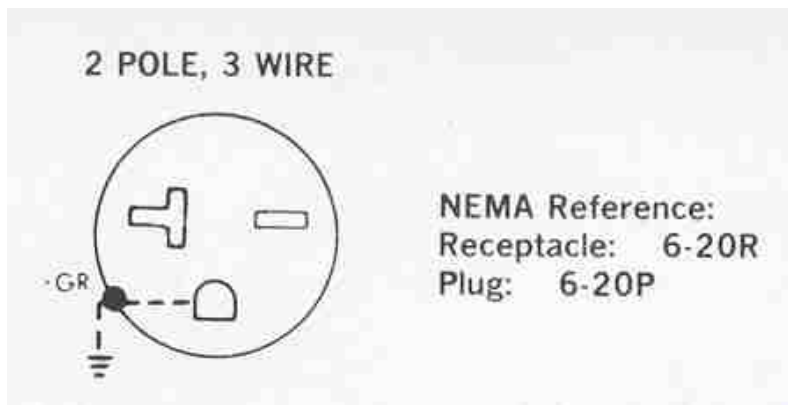

ADA Compliance

§4.28.2 ((CFR) – 28CFR Part 36)
“For Alarms”.

§4.27 “For controls and operating mechanisms”.

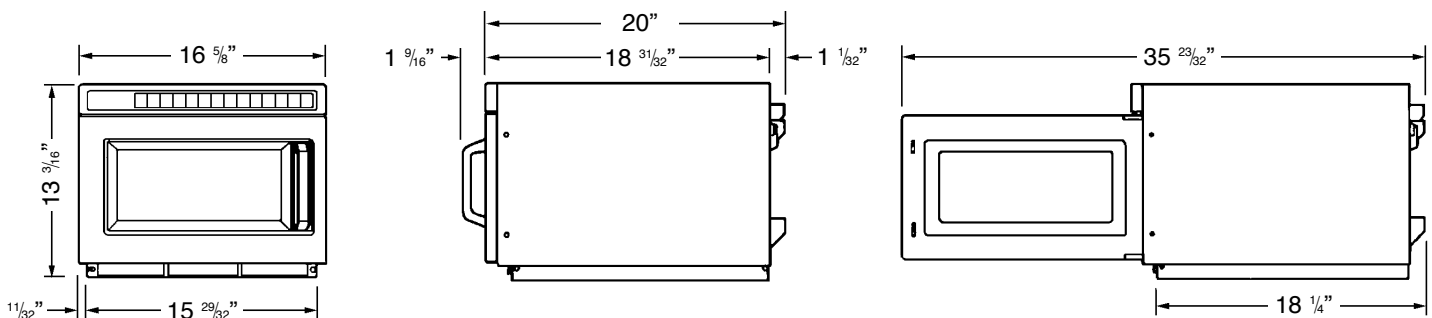

Panasonic Commercial Appliances

Division of PNA
Executive Offices:
One Panasonic Way, Panazip 4A-1, Secaucus, NJ 07094
Toll Free: 1-888-350-9590
www.panasonic.com/cmo