



E9341 Single Pan Fryer



Short Form Specification

Unit to be Falcon F900 Series high performance electric single pan fryer. Pan will be 304 grade stainless steel. Unit to be supplied upon adjustable feet with a working oil capacity of 20 litres.

The pan will be of open well design to allow easy cleaning of the pan. Basket to be positioned at pan rear for oil drain off and storage.

Oil to be drained from pan into oil bucket that is to be self-contained inside the unit base. The oil temperature will be thermostatically controlled via precise controls from 130-190°C. The unit will have safety thermostat fitted as standard to prevent unit from overheating.

The hob will be constructed from 2mm 304 grade stainless steel. Hobs will be laser cut with right-angled edges to allow joining of units with no gaps between hobs. Exterior panels are Scotch Brite finish stainless steel. Control knobs to be marked showing temperature positions with a bezel behind control knob to prevent water ingress.

Key Features

- “Eco” setting reduces power consumption during pre-heating and can be used as fat melt mode
- Pressed pan requires just 20 litres of oil to fill
- Two baskets supplied
- Manual control system for ease of use
- Fish plate supplied as standard
- Safe swivel element for better pan cleaning access
- Filter bucket situated directly below 1” drain valve
- IPX5 rated
- Supplied upon adjustable stainless steel feet
- 2mm thick 304 grade stainless steel hob
- Laser cut hob allows edge to edge joining of units
- Stainless steel external panels with Scotch Brite finish
- Dynamic Link System Compatible



Integrated linking system allows gap free installation to create a seamless, continuous cookline.

Patent pending, application no. GB 1511389.7

Optional Accessories

- Front hob rail
- Castors
- Hob extension
- Front and side kick strips



E9341 Single Pan Fryer

Model Dimensions (mm)

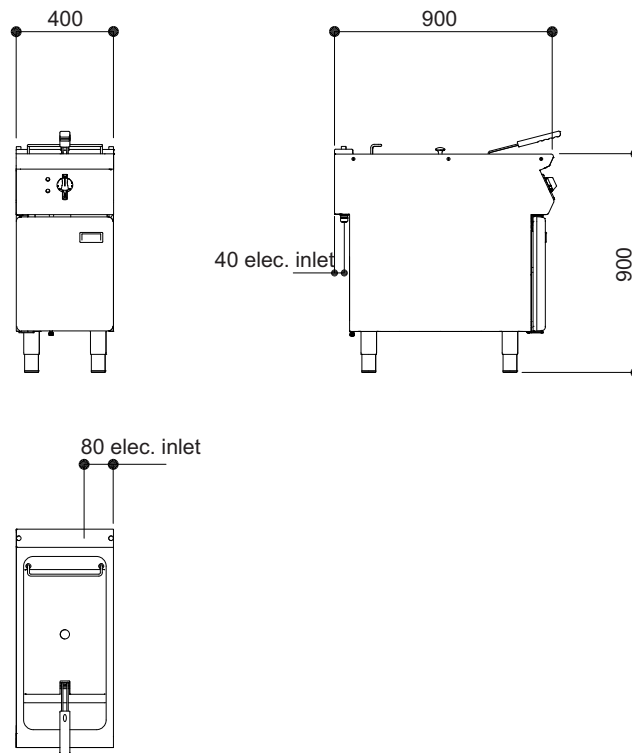

Specification Details

Electrical rating (kW)	19
Electrical supply voltage	400V 3N~ 50/60Hz
Required electrical supply (A)	32
Element rating (kW)	19
Oil capacity (litres)	20
Packed dimensions (mm)	490 (w) x 1000 (d) x 1015 (h)

Installation Note:

Please consult local legislation with regard to installation of cooking equipment.