

Technical data sheet for

EC40D5 ON THE SK40A STAND

Full Size 5 Tray Digital / Electric Combi Oven on a Stainless Steel Stand



STANDARD FEATURES

- Electric direct steam version
- 5 x 1/1 GN tray capacity
- 5 x 600mm x 400mm tray capacity
- 70mm tray spacing
- Compact 777mm wide
- 7kW heating power
- 2 speed fan
- LED HVS (High Visibility System) alphanumeric display for temperature, Clima, time and core temperature
- 2.4" LCD-TFT colour display with rapid selection scroller knob for program and setting selection
- Over 95 preset recipe programs
- 99 free programs with up to 9 cycles in automatic sequence
- Manual cooking with three cooking modes - Convection (50°C-260°C), Steam (50°C-130°C), Combi (50°C-260°C)
- Clima - automatic measurement and control for humidity levels in the cooking chamber
- Manual pre-heating
- Auto reverse (automatic inversion of the direction of the fan) for perfectly uniform cooking
- Automatic chamber venting control
- ECOVAPOR - automatic control of the steam saturation in the cooking chamber
- ECOSPEED - oven optimises and controls the delivery of energy to maintain correct cooking temperature
- Core temperature probe ready
- USB connection
- Automatic LCS (Liquid Clean System) with Combi Clean liquid
- 7 automatic cleaning programs
- Externally connected hand shower
- Timed LED chamber lighting
- Self-diagnostic operation check before and during use, with detailed description and audible fault warnings
- Triple action water filter cartridge and filter head included

ACCESSORIES

- Multipoint core temperature probe
- Turbofan SK40A Oven Stand



EC40D5

Unit shall be a Blue Seal electrically heated Turbofan direct steam injection combination convection steam oven. The oven shall have a stainless steel oven chamber with 5 x 1/1 GN capacity, 7.25kW power rating and a 2 speed auto-reversing direction fan. Oven door shall be vented safe touch and feature LED oven chamber lighting. Electronic touch control panel shall provide cooking mode selection, 10 one touch favourite program keys, digital displays for temperature, time, humidity and programs, and a scrolling control knob for operation. Convection, Steam, and Combi cooking modes shall be usable in manual mode and program modes. Unit shall be optional core temp probe ready. Unit shall include as standard a self contained Automatic cleaning system with Liquid Clean System (LCS). A water hand shower shall be included as standard. Oven shall be able to be bench mounted on 100mm feet or mounted on Turbofan oven stand model SK40A. Unit shall be supplied in 100% recyclable shipping packaging.

SK40A

Unit shall be a Blue Seal Turbofan stainless steel oven stand. The stand shall be constructed from stainless steel tube with 4 adjustable feet. It shall be fitted with 6 tray runners suitable for 1/1 GN pans and 600 x 400 trays. The stand shall be fully compatible with, and support, Turbofan Combi Oven models EC40M5, EC40M7, EC40D5 and EC40D7. Unit shall be supplied in 100% recyclable shipping packaging.

EC40D5 Full Size Digital/ Electric Combi Oven on a Stainless Steel Stand

Dimensions

Width	777mm
Depth	835mm
Height	777mm
Weight	74kg

Packed Dimensions

Width	910mm
Depth	865mm
Height	900mm
Weight	85kg
Volume	0.71 m ³

Shelves

1/1 GN	5
Shelf Spacings	70mm

Power connection requirements

Multi pole circuit breaker and all pole disconnection isolator switch installed near the appliance.

Electrical requirements

400-415V, 50Hz, 3P+N+E, 7.25kW, 11A/ph or 230-240V, 50Hz, 1P+N+E, 7.25kW, 32A

Water connection requirements

Water Supply

2 x R3/4 connections

Cold Water

Flow pressure 200-500 kPa

Shut off valve with back flow prevention

Water Quality

- total hardness 60-90 ppm
- pH > 7.5
- Cl-(chloride) <30 ppm
- temperature < 50°C

Drain

- Funnel waste trap/tundish required
- 40 mm outlet
- Minimum fall/slope for waste 4°

SK40A Stainless Steel Stand

All stainless steel welded frame oven stand for Turbofan EC40 5 tray and 7 tray Series Combi ovens

6 position tray runners

4 height adjustable feet

Supplied CKD for assembly on site

External Dimensions (SK40A Oven Stand)

Width	810mm
Height	854mm
Depth	650mm

Nett Weight (SK40A Oven Stand)

19kg

Packing Data (SK40A Oven Stand)

22kg	
0.11m ³	
Width	830mm
Height	880mm
Depth	160mm

INSTALLATION CLEARANCES

Installation requirements (for precise installation instructions, please refer to the unit's installation manual).

- rear 50mm
- right 50mm*
- left 50mm*

*For recessed installations a minimum of 500mm clearance must be maintained on one of the sides.

If heat sources are located near the Turbofan Combi, ensure that a minimum distance of 400mm is maintained.

Install in accordance with local body regulations only on horizontal surfaces and not against combustible walls.



blue-seal.co.uk
turbofanoven.com

United Kingdom
Blue Seal Limited

Unit 67
Gravelly Business Park
Gravelly
Birmingham B24 8TQ
England
Telephone 0121-327 5575
Facsimile 0121-327 9711
sales@blue-seal.co.uk
www.blue-seal.co.uk

Australia
Moffat Pty Limited

740 Springvale Road
Mulgrave, Victoria 3170
Australia
Telephone 03-9518 3888
Facsimile 03-9518 3833
vsales@moffatcom.au
www.moffatcom.au

New Zealand
Moffat Limited

Christchurch
45 Illinois Drive
Izone Business Hub
Rolleston 7675
Telephone +64 3-983 6600
Facsimile +64 3-983 6660
sales@moffatco.nz
www.moffatco.nz

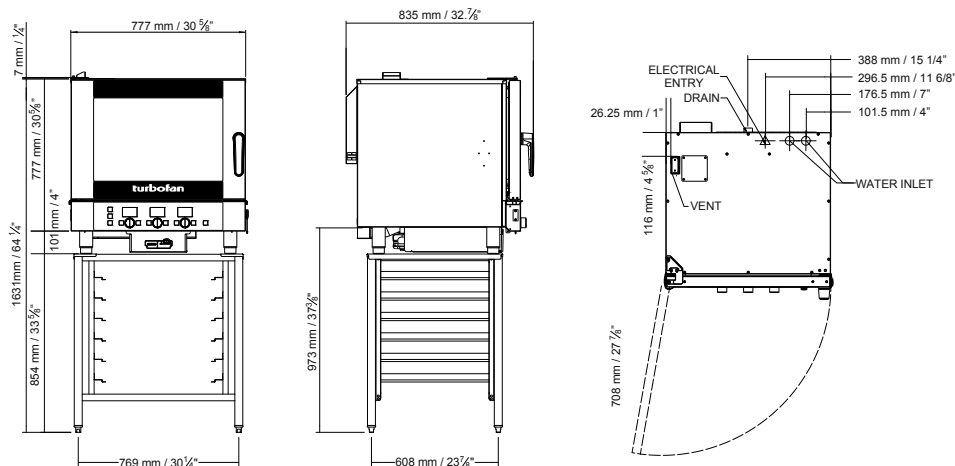

Manufactured by:
Moffat Limited
45 Illinois Drive, Izone Business Hub
Rolleston 7675, New Zealand

In line with policy to continually develop and improve its products, Moffat Limited reserves the right to change specifications and design without notice.

© Copyright Moffat Ltd
UK.T.C.S.0119



an Ali Group Company



The Spirit of Excellence