

ARCTICA
REFRIGERATION

New Refrigerant

INSTRUCTION MANUAL

SALADETTE

Warranty

Tel: 03701 647 647

Email: service@lockhartcatering.com

Please read the user' s manual before you use this product.
If you request unnecessary services, you may waste money.
Thus, fix simple troubles by yourself which you have found.



SALAD

Installation, use and maintenance instructions

INDEX

1 Introduction.....	2
2 The manufacturer cannot be held liable in the following cases.....	4
3 Transportation and storage.....	5
4 Commissioning.....	5
4.1 Positioning.....	5
4.2 Initial cleaning.....	6
4.3 Connection to electrical supply.....	6
4.4 Connection to drains.....	7
5 Technical characteristics.....	8
5.1 Noise and vibration.....	8
5.2 Possible applications.....	8
6 Usage.....	8
6.1 Operating instruction.....	8
6.2 Storage of food-stuffs.....	13
7 Maintenance.....	13
7.1 Periodic cleaning.....	13
7.2 Cleaning of condenser.....	13
7.3 Period of inactivity of cabinet.....	14
8 Trouble shooting and remedies.....	14
8.1 If the cabinet does not operate.....	14
8.2 If the required temperature is not achieved.....	14
8.3 If the cabinet leaks water.....	15
8.4 If the cabinet is unacceptably noisy.....	15
8.5 Improbable risks.....	15
9 Substitution of spares.....	15
10 DISMANTLING.....	16
Technical Parameters.....	17
Official approval and rules.....	18
Correct disposal of this product.....	18



1 INTRODUCTION

Please read instructions before using this appliance.

IMPORTANT SAFETY INSTRUCTION

- ▲ To reduce the risk of fire, electric shock, or injury to persons when using your product, basic safety precautions should be followed, including the following.
- ▲ This appliance must be properly installed and located in accordance with the Installation Instruction before it is used.
- ▲ Before the appliance is plugged in, ensure that the rated voltage corresponds to the voltage of the electrical system in your home. The power plug should have its own independent socket. Using adapters may cause overheating or burning.
- ▲ This appliance can be used by children aged from 8 years and above and persons with reduced physical, sensory or mental capabilities or lack of experience and knowledge if they have been given supervision or instruction concerning use of the appliance in a safe way and understand the hazards involved.
- ▲ Children shall not play with the appliance.
- ▲ Cleaning and user maintenance shall not be made by children without supervision.
- ▲ If the supply cord is damaged, it must be replaced by the manufacturer or its service agent or a similarly qualified person in order to avoid a hazard.
- ▲ Connect to properly grounded outlets only. Avoid the use of extension cords. Do not run cord under carpeting, runners or the like. Arrange cord away from traffic area and where it will not create a tripping hazard.
- ▲ Always unplug appliance when not in use and before cleaning, adjusting or maintaining this machine. To disconnect appliance, turn switch off and remove plug from power source.



- ▲ Do not disconnect by pulling on the cord. Always disconnect by grasping and pulling on the plug top.
- ▲ Do not pull out the cord or touch the power plug with wet hands. Clean water or dust from the power plug and insert it with the ends of the pins securely connected.
- ▲ Do not use outdoors.
- ▲ Do not splash water on the appliance. It may cause a malfunction or electric shock.
- ▲ Do not disassemble, repair or alter the appliance. It may cause fire or abnormal operations, which may lead to injury.
- ▲ After your fridge-freezer is in operation, do not touch the cold surfaces in the freezer compartment, particularly when hands are damp or wet. Skin may adhere to these extremely cold surfaces.
- ▲ Never place glass products in the freezer because they may be broken when their inner contents are frozen.
- ▲ The refrigerant and insulation blowing gas used in the appliance require special disposal procedures. When disposal, please consult with service agent or a similarly qualified person.
- ▲ Do not store explosive substances such as aerosol cans with a flammable propellant in this appliance.
- ▲ WARNING: Keep clear of obstruction all ventilation openings in the appliance enclosure or in the structure for building-in.
- ▲ WARNING: Do not use mechanical devices or other means to accelerate the defrosting process, other than those recommended by the manufacturer.
- ▲ WARNING: Do not damage the refrigerant circuit.
- ▲ WARNING: Do not use electrical appliances inside the food storage compartments of the appliance, unless they are of the type recommended by the manufacturer.



Warning: Risk of fire / flammable materials

CAUTION: RISK OF FIRE AND EXPLOSION WITH FLAMMABLE REFRIGERANT R600a/ R290.

▲ If you need the electronic version instruction manual, please ask the manufacturer or its service agent .

▲ Max. Load of shelf is 80 kg.

This instruction manual provides all the necessary information regarding:

- ▲ use of the refrigerator
- ▲ technical specifications
- ▲ installation and handling
- ▲ operator procedures and instructions
- ▲ maintenance operation

The manual is to be considered an integral part of the refrigerator and should be stored in a safe place for father consult to permit a good working life of the refrigerator.

The appliance is intended for commercial use only.

2 The manufacturer cannot be held liable in the following cases:

- improper installation (not in accordance with the guidelines indicated herein)
- misuse of the refrigerator
- power supply defects
- improper or inadequate maintenance
- unauthorised modification or tampering
- use of non-original spare parts
- partial or total failure to comply with the instructions

All electrical equipment can be hazardous to health. Current standards and legal requirements must be complied with during the installation and use of any equipment.



3 TRANSPORTATION AND STORAGE

The equipment is wrapped in absorbent material and contained and fixed within a wooden platform and paper box.

Whilst awaiting by definitive collection, these should be stored within a protected and covered environment at a temperature between -25°C / $+55^{\circ}\text{C}$, with ambient humidity between 30°C / 95%. Do not stack more than three items.

4 COMMISSIONING

Carefully read the label on the equipment, do not cover for any reason whatsoever. and replace them immediately if damaged. Do not remove protection or panelling that require the usage of tools.

4.1 POSITIONING

Ensure that in respect of the dimensions, the space reserved for the equipment permits its correct utilisation and ease of maintenance. After carefully unpacking the display case, remove the white PVC protective film and all of the manufacturer's material which safeguards the item in transit. Place the cabinet on a flat surface and level it by screwing and adjusting the leveling legs to ensure its efficient operation. The cabinet must be lifted only from the exterior of the base to avoid the possibility of damage. Do not move the cabinet by application of pressure to the surface. if the device has been positioned horizontally (integral condensing unit). wait two hours before activating it. Packing and protective film should be disposed off as indicated by the local authorities. The equipment must not be installed within explosive ambience, In the open air or exposed to



rain the correct siting is; distant from direct sources (radiators, direct lighting, etc...) and protected from direct sunlight and draughts. Air circulation must be freely maintained around the condensing unit, be it integral or remote. In observance of these specific conditions will detrimentally affect the cabinet.

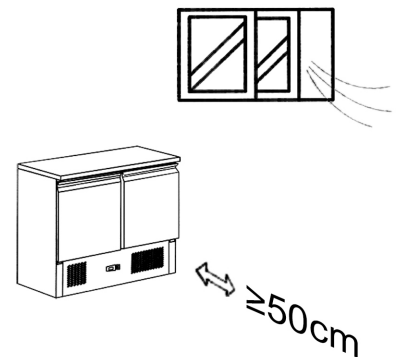

4.2 INITIAL CLEANING

Before use all parts of the cabinet should be cleaned,

For the walls and all the internal parts use an antibacterial detergent.

For the plastic parts use a moistened cloth.

Dry with a soft clean cloth. use little or no water.

Do not use harsh or abrasive solvents or detergents

During cleaning do not approach bare-handed those parts which could cut (evaporator, condenser, etc.)and always use protective gloves.

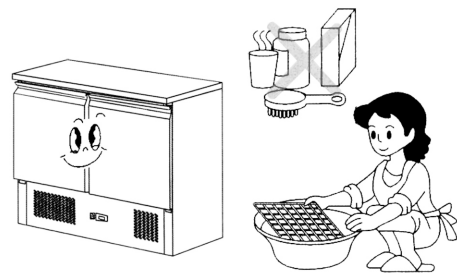

4.3 Electrical connection

Check that the supply conforms to the requirements listed on the factory label and that it is provided with a fall-safe protection or automatic circuit



breaker with an efficient earth connection. Should there not be an electrical safety feature have this introduced by a qualified person. by means of a omnipolar switch as indicated in the safety regulations with a means of a omnipolar switch as indicated in the safety regulations with a minimum clearance of the contacts of 3 mm. where the cabinet has to be installed at some distance from the electrical source. ensure that the conforms to the local regulations. Cabinet supplied with integral condensing units are provided with an appropriate plug fitted with a neutral and earth; the supply cable must be well stretched (avoid coilling and superimposition). it must not be exposed to the possibility of damage by third parties. it should not be in contact with liquids, water or heat sources. in the event of damage it must be replaced by qualified personnel. Always avoid the use of reducers or adapters.

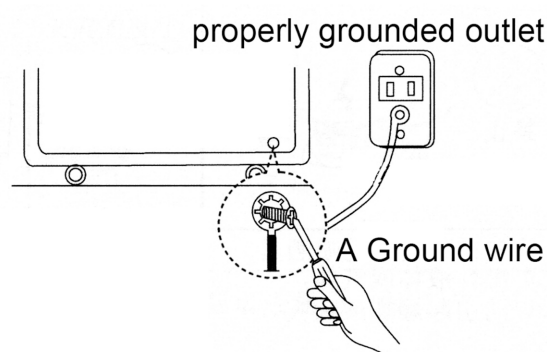
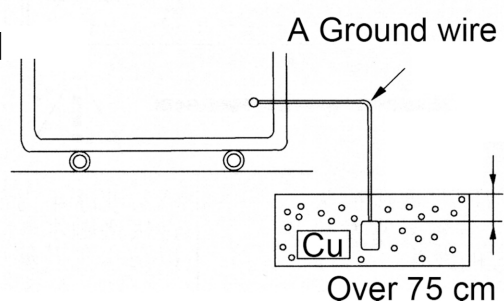
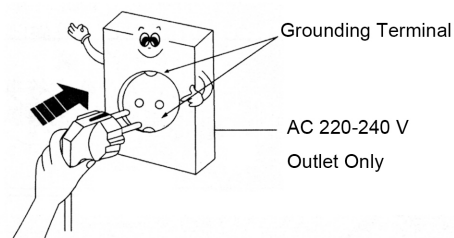

4.4 CONNECTION TO DRAINS

The dispersal of defrost water is automatic in all models with integral condensing unit.



5 TECHNICAL CHARACTERISTICS

5.1 NOISE AND VIBRATION

The sound level of the equipment fitted with integral hermetic condensing unit does not exceed 70 dB ,it is therefore not necessary to provide sound insulation. Under normal conditions the equipment does not generate vibrations which affect surroundings.

5.2 POSSIBLE USAGES

Do not utilise the equipment to store medical supplies.

The optimum operational ambient temperatures are between $+10^{\circ}\text{C}$ / $+32^{\circ}\text{C}$.

The possible application are show be low:salad (10°C): refrigeration, preparation, and sale of salads, fruits. Vegetables and cold dishes.

6 USAGE

6.1 Operating Instruction

6.1.1 These devices are activated by one or two switches and an electronic control panel.

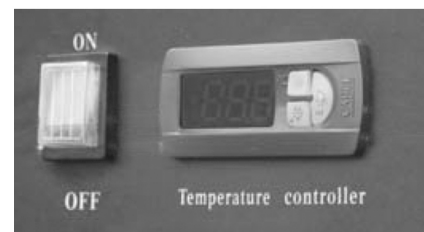

6.1.2. After connecting the power supply, press the “POWER” switch on the controller keyboard (Red Indicator Light ON), the fridge will come to work. The microcomputer controller, installed in the controller keyboard, could automatically adjust the temperature ranges. This intelligent digital controller works as: if the temperature increases and reaches set point plus differential the compressor is started and then turned off when the temperature reaches the set point value again.



6.1.3. Microcomputer Controller Operation Instruction:

Display and functions:

During normal operation, the controller displays the value of the probe set using parameter/4(=1 ambient probe, default,=2 second probe, =3 third probe).In addition, the display has LEDs that indicate the activation of the control functions(see Table 1),while the 3 buttons can be used to activate/deactivate some of the functions (see table 2).

LEDs and associated functions Tab.1

icon	function	normal operation			start up
		ON	OFF	blink	
	Compressor	on	off	request	ON
	fan	on	off	request	ON
	defrost	on	off	request	ON
AUX	aux	output on	output off	-	ON
	alarm	all	no alarm	-	ON
	clock	RTC fitted and enabled,at least 1 time band set	RTC not fitted or disabled,not even 1 time band set	-	ON if RTC fitted

Table of functions activated by the buttons Tab.2

button		normal operation		start up	
		pressing the button alone	pressed together		
	up ON/OFF	more than 3s toggle ON/OFF	pressed together start/ stop continuous cycle	Pressed together start	for 1s display firmware vers. code
	down defrost	more than 3s: start/stop defrost			parameter reset procedure
	set mute	-1s: display/set the set point -more than 3s: access parameter setting menu(enter password 22) -mute audible alarm (buzzer)	-		



Setting the set point(desired temperature)

- press SET for 1s the set value will start flashing after a few moments;
- increase or decrease the value using UP or DOWN;
- press SET to confirm the new value.

Switching the device ON/OFF

Press UP for more than 3s. the control and defrost algorithms are now disabled and the instrument displays the message “OFF” alternating with the temperature read by the set probe.

Manual defrost

Press for DOWN more than 3s (the defrost starts only the temperature conditions are valid).

Continuous cycle

Press UP and DOWN together for more than 3s.

Table of alarms

Alam code	buzzer and alarm relay	LED	Description	Parametri coinvolti
E0	active	ON	probe 1 error=control	-
E1	inactive	ON	probe 2 error=defrost	[d0=0/1]
dr	active	ON	open door alarm	[A4=6][+A7]
LO	active	ON	low temperature alarm	[AL][Ad]
HI	active	ON	high temperature alarm	[Ah][Ad]
EE	inactive	ON	unit parameter error	-
EF	inactive	ON	operating parameter error	-
Ed	inactive	ON	defrost ended by timeout	[dP][dt][d4][A8]
dF	inactive	ON	defrost running	[d6=0]



Dixell XR02CX XR03CX XR06CX

1. Microcomputer panel sketch map, meanings of running indicator light and LED showing.
2. **SET** To display target set point, in programming mode it selects a parameter or confirm an operation.



(Mod. XR06CX)

❄ To start a manual defrost.

⬆ In programming mode it browses the parameter codes or increases the displayed value .

⬇_{AUX} In programming mode it browses the parameter codes or decreases the displayed value .

⬇+⬆ To lock or unlock the keyboard

SET+⬇ To enter in programming mode

SET+⬆ To return to room temperature display .

3. How to see the point .

Push and immediately release the SET key, the set point will be showed;
Push and immediately release the SET key or wait about 5s to return to normal visualisation.

4. How to change the setpoint .

Push the SET key for more than 2 seconds to change the Set point value;
The value of the set point will be displayed and the “°C” or “°F” LED starts blinking;

To change the Set value push the ⬆ or ⬇_{AUX} arrows.

To memorise the new set point value push the SET key again or wait 10s.

5. How to start a manual defrost .

Push the DEF ❄ key for more than 2 seconds and a manual defrost will start .

LED	MODE	SIGNIFICATO
❄	On	Compressor enabled
	Flashing	Anti short cycle delay enabled (AC parameter)
❄	On	Defrost in progress
	Flashing	Dripping in progress
🌀	On	Fans output enabled
	Flashing	Fans delay after defrost
°C	On	Measurement unit
	Flashing	Programming mode
°F	On	Measurement unit
	Flashing	Programming mode



6. How to change a parameter value

To change the parameter's value operate as follows:

Enter the Programming mode by pressing the **SET+▽** keys for 3s
 (“°C” or “°F” LED starts blinking).

Select the required parameter. Press the “SET” key to display its value
 Use **△** or **▽_{AUX}** to change its value.

Press “SET” to store the new value and move to the following parameter.

To exit: Press **SET+△** or wait 15s without pressing a key.

NOTE: the set value is stored even when the procedure is exited by waiting the time-out to expire.

7. To lock the keyboard .

Keep pressed for more than 3s the **▽+△** keys.

The “OF” message will be displayed and the keyboard will be locked.

If a key is pressed more than 3s the “OF” message will be displayed.

8. To unlock the keyboard .

Keep pressed together for more than 3s the **▽+△** keys till the “on” message will be displayed .

9. Alarm signalling .

Mess.	Cause	Outputs
"P1"	Room probe failure	Compressor output according to “Cy” e “Cn”
"P2"	Evaporator probe failure	Defrost end is timed
"HA"	Maximum temperature alarm	Outputs unchanged
"LA"	Minimum temperature alarm	Outputs unchanged
"EA"	External alarm	Outputs unchanged
"CA"	Serious external alarm	All outputs OFF
"dA"	Door Open	Compressor and fans restarts



6.2 STORAGE OF FOOD-STUFFS

In order to obtain the best functioning of the case it is necessary to observe the following instruction:

- Place the merchandise into the unit only after it has reached the desired operating temperature given on the digital display.
- Do not place uncovered hot foods or liquids inside the unit
- Package or protect foods when possible
- Do not limit the circulation of air inside the call with superfluous obstacles.
- Avoid frequent or prolonged openings of the door/drawers
- Wait a few moments before reopening the door/drawer just after it has been closed.

Whilst stocking only open and fill a drawer at a time to eliminate the risk of over-balancing or ask to the supplier the fixable feets.

7 MAINTENANCE

7.1 PERIODIC CLEANING

For hygienic reasons and improved performance clean at least once a month the internal basin. Especially the hole for water out going, need keep clean always, First perform a manual defrosting cycle (par. 6.1), When complete, switch off the power supply and clean the inside following the instructions given in par. 4.2 (initial cleaning).

7.2 CLEANING OF CONDENSER

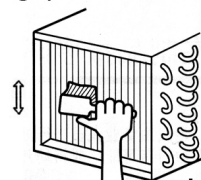

For improved performance clean the condenser at least once a week.

Before beginning turn off the equipment, and disconnect the plug. Close and protect the unit.

- Unscrew, rotate and remove protective grill
- Remove the dust deposited on the front surface of the condenser using a brush and a vacuum cleaner and restore previous conditions.



7.3 PERIOD OF INACTIVITY OF CABINET

During periods of inactivity, remove the products from the cabinet and then follow these directions:

- Remove the plug out from the outlet and carefully clean the unit as per periodic cleaning
- Cover the cabinet whit a cloth that allows air circulation in the interior.

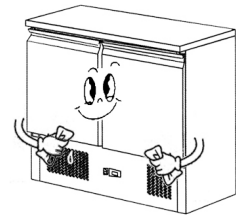

8 TROUBLE SHOOTING AND REMEDIES

Often, the malfunction of a unit is due to simple causes which can easily be eliminated without contacting a technician.

Therefore execute the following controls



8.1 If the cabinet does not operate, make sure that:

- The plug has been correctly inserted into the socket.
- The supply cord is not damaged.

8.2 If the required temperature is not achieved, make sure that;

- The command switch is turned on.
- The electronic control panel is correctly regulated (see 6.1. 3).
- The cabinet is neither in the defrosting phase nor in the post-defrosting pase.
- The evaporator is not covered with frost (see 6.1.3).
- The condenser is not blocked with dust.
- The cabinet is not located near heat sources or its condensing unit has uninterrupted air flow.



- The stored foods or other objects do not inhibit proper closing of the unit.
- The cabinet is not working in anomalous conditions (overloaded, loaded with hot food, or loaded in a way that prevents proper air circulation).

8.3 If the cabinet leaks water, make that:

- The collecting container or the device for condensing water elimination are not damaged.
- The discharge outlets are not blocked or obstructed.
- The cabinet has been properly leveled.

8.4 If the cabinet is unacceptably noisy, make sure that:

- The frame does not have loose screws or bolts.
- The cabinet has been laid in a stable position and correctly leveled.

If, after all these controls, the malfunctioning continues, it is advisable to contact technical assistance. Be prepared to supply the following information:

- The model trade name and the serial number (both can be found on the technical data plate).
- The alarm codes appearing on the display of the control panel.

8.5 IMPROBABLE RISKS

In case of fire unplug the cabinet, if possible, and use a powder fire extinguisher.

9 SUBSTITUTION OF SPARES



Before commencing any service or maintenance work, isolate the cabinet from the electrical supply.

Always fit original spares which may be obtained from an authorized concessionaire or stockist.

10 DISMANTLING

The scrapping of the cabinet requires to be undertaken by specialized company, licensed by the local authorities, and observing local statutes. Polyurethane foaming material, not fire-resistant, when deal with the material, should be according with local law and statute.

- The cabinet consists of:
- Structure in steel plate,
- Electrical components and cables,
- Electrical compressor.
- Plastic materials,
- Refrigerant fluid which must not be discharged into the atmosphere.

ALL THE RESPONSIBILITY FOR THE FAILURE TO RESPECT THE EXISTING LOCAL STATUTES ARE THE RESPONSIBILITY OF THE OWNER.

Meaning of crossed –out wheeled dustbin:

Do not dispose of electrical appliances as unsorted municipal waste, use separate collection facilities. Contact you local government for information regarding the collection systems available. If electrical appliances are disposed of in landfills or dumps, hazardous substances can leak into the groundwater and get into the food chain, damaging your health and well-being. When replacing old appliances with new ones, the retailer is legally obligated to take back your old appliance for disposals at least free of charge.



Technical Parameters

Model	Rated voltage	Rated power (W)	Current (A)	Volume (L)	Safety climate class	Refrigerant	Amount (g)	Dimension WxDxH(mm)	Net volume (L)	Energy consumption over 24 hours (E24h)	Annual energy consumption (AEC)	Energy efficiency index (EEI)	Energy efficiency class
HEF568	220-240V, 50Hz	310	2	300	4, 5	R600a	60	900 x 700 x 888	-	2.12	-	-	-
HED499	220-240V, 50Hz	220	1.2	300	4, 5	R600a	60	900 x 700 x 880	169	1.16	423	19	A
HEF959	220-240V, 50Hz	220	1.2	300	4, 5	R600a	60	900 x 700 x 880	97	1.45	529	26	B
HEF961	220-240V, 50Hz	310	2	300	4, 5	R600a	60	900 x 700 x 1100	-	2.12	-	-	-
HED501	220-240V, 50Hz	310	2	300	4, 5	R600a	60	900 x 700 x 1040	-	2.12	-	-	-
HEF960	220-240V, 50Hz	220	1.2	380	4, 5	R600a	60	1365 x 700 x 880	145	1.78	650	30	B
HEF569	220-240V, 50Hz	310	2	380	4, 5	R600a	70	1365 x 700 x 888	-	2.55	-	-	-
HED500	220-240V, 50Hz	220	1.2	380	4, 5	R600a	70	1365 x 700 x 880	254	1.6	584	24	A
HEF962	220-240V, 50Hz	310	2	380	4, 5	R600a	70	1365 x 700 x 1100	-	2.55	-	-	-
HEF570	220-240V, 50Hz	310	2	380	4, 5	R600a	70	1365 x 700 x 1040	-	2.55	-	-	-

NOTES :If the technical data has any changes, we will not notify you any longer.



OFFICIAL APPROVAL AND RULES

Our products full fill the present rules

Latest version of following directives and standards

EN 60335-1

EN 60335-2-89

EN 62233

EN 55014-1

EN 61000-3-2

EN 61000-3-3

EN 55014-2

**UK
CA**

CORRECT DISPOSAL OF THIS PRODUCT

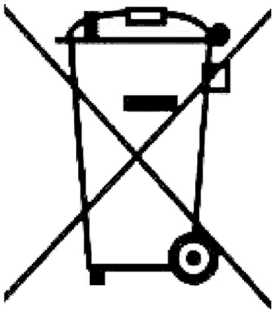

This marking indicates that this product should not be disposed with other household wastes throughout the GB. To prevent possible harm to the environment or human health from uncontrolled waste disposal, recycle it responsibly to promote the sustainable reuse of material resources. To return your used device, please use the return and collection systems or contact the retailer where the product was purchased. They can take this product for environmental safe recycling.

W081157001

version number 20220514

