

E3830, E3860 & E3865 DOMINATOR *PLUS* Fryers



INSTALLATION and SERVICING INSTRUCTIONS

IMPORTANT

The installer must ensure that the installation of the appliance is in conformity with these instructions and National Regulations in force at the time of installation. Particular attention **MUST** be paid to:

BS7671 IEE Wiring Regulations
Electricity at Work Regulations
Health And Safety At Work Act
Fire Precautions Act

This appliance has been CE-marked on the basis of compliance with the Low Voltage and EMC Directives for the voltages stated on the data plate.

WARNING: THIS APPLIANCE MUST BE EARTHED.

On completion of the installation, these instructions should be left with the Engineer-in-Charge for reference during servicing. Further to this, The Users Instructions should be handed over to the User, having had a demonstration of the operation and cleaning of the appliance.

IT IS MOST IMPORTANT THAT THESE INSTRUCTIONS BE CONSULTED BEFORE INSTALLING AND COMMISSIONING THIS APPLIANCE. FAILURE TO COMPLY WITH THE SPECIFIED PROCEDURES MAY RESULT IN DAMAGE OR THE NEED FOR A SERVICE CALL.

PREVENTATIVE MAINTENANCE CONTRACT

In order to obtain maximum performance from this unit we would recommend that a maintenance contract be arranged with **SERVICELINE**. Visits may then be made at agreed intervals to carry out adjustments and repairs. A quotation will be given upon request to the contact numbers below.



WEEE Directive Registration No. WEE/DC0059TT/PRO

At end of unit life, dispose of appliance and any replacement parts in a safe manner, via a licensed waste handler.

Units are designed to be dismantled easily and recycling of all material is encouraged whenever practicable.

Falcon Foodservice Equipment

HEAD OFFICE AND WORKS

Wallace View, Hillfoots Road, Stirling, FK9 5PY. Scotland.

SERVICELINE CONTACT

Phone: 01438 363 000

Fax: 01438 369 900

T100774 Ref. 6

IMPORTANT INFORMATION

Warranty Policy Shortlist

Warranty does not cover :-

- Correcting faults caused by incorrect installation of a product.
- Where an engineer cannot gain access to a site or a product.
- Repeat commission visits.
- Replacement of any parts where damage has been caused by misuse.
- Engineer waiting time will be chargeable.
- Routine maintenance and cleaning.
- Gas conversions i.e. Natural to Propane gas.
- Descaling of water products and cleaning of water sensors where softeners/ conditioners are not fitted, or are fitted and not maintained.
- Blocked drains
- Independent steam generation systems.
- Gas, water and electrical supply external to unit.
- Light bulbs
- Re-installing vacuum in kettle jackets.
- Replacement of grill burner ceramics when damage has been clearly caused by misuse.
- Where an engineer finds no fault with a product that has been reported faulty.
- Re-setting or adjustment of thermostats when unit is operating to specification.
- Cleaning and unblocking of fryer filter systems due to customer misuse.
- Lubrication and adjustment of door catches.
- Cleaning and Maintenance
 - Cleaning of burner jets
 - Poor combustion caused by lack of cleaning
 - Lubrication of moving parts
 - Lubrication of gas cocks
 - Cleaning/adjustment of pilots
 - Correction of gas pressure to appliance.
 - Renewing of electric cable ends.
 - Replacement of fuses
 - Corrosion caused by use of chemical cleaners.

SECTION 1 - INSTALLATION

UNLESS OTHERWISE STATED, PARTS WHICH HAVE BEEN PROTECTED BY THE MANUFACTURER ARE NOT TO BE ADJUSTED BY THE INSTALLER.

1.1 MODEL NUMBERS, NETT WEIGHTS and DIMENSIONS

Model	Width (mm)	Depth (mm)	Height (mm)	Weight (kg)
E3830 Fryer	300	770	890	45
E3860 Fryer	600	770	890	73
E3865 Fryer	600	770	890	85

1.2 SITING

Before connecting appliance to electricity supply, it must be correctly positioned and levelled. Levelling is effected by turning the lower area of the adjustable legs. If desired, feet that allow floor-fixing may be specified at time of order.

1.3 ELECTRICAL CONNECTION

The unit is designed for use on AC supplies only and terminals are normally arranged for either 2 phase operation (*E3830 model*) or 3 phase (*E3860 & E3865 models*).

If single phase supply has been specified, a bridging link is provided with the appliance and should be connected as detailed below.

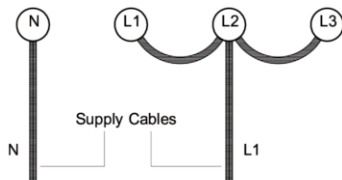

Cable entry is located at appliance rear in the form of a cable gland.

A suitably rated isolating switch with contact separation of at least 3mm in all poles must be installed. All wiring must be executed in accordance with regulations listed on title page of this document.

Warning - This appliance must be earthed.

1.4 ELECTRICAL RATINGS

The electrical rating is stated on appliance data plate.

SECTION 2 - ASSEMBLY and COMMISSIONING

2.1 ASSEMBLY

The appliance is supplied complete and ready to be connected to the mains supply.

Position unit in desired location and level it. Turn lower section of each leg clockwise to raise corresponding corner height or anti-clockwise to lower it.

Castors

Undo grub screw and use a spanner to adjust the castor height. Turn clockwise to raise level and anti-clockwise to lower.

Secure grub screw when task is completed.

Grub screw

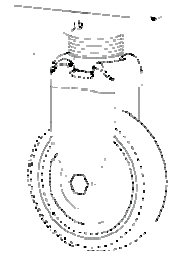

2.2 CONNECTION TO THE ELECTRICAL SUPPLY

To gain access to terminals, proceed as follows:-

Remove fixings at unit rear to remove cover and access electrical connections.

Undo cable gland.

Feed cable through cable gland into electrical box.

Connect leads to respective terminals.

Tighten cable gland.

Replace cover.

If single phase connection is required, refer to Section 1.3 for details.

2.3 COMMISSIONING

Fill pan(s) with oil to mark on element guard (*i.e. approximately 20 litres for E3830 model and 40 litres for E3860 & E3865 models*) and switch on at isolator switch. Turn thermostat to maximum setting and check that it operates at the correct temperature of 190°C.

The importance of never switching on the elements unless they are covered by oil or water must be stressed. DO NOT USE SOLID FAT.

2.4 INSTRUCTION TO USER

After installing and commissioning appliance, hand user instructions to user or purchaser.

Ensure that person(s) responsible is (are) made familiar with use and maintenance of unit.

SECTION 3 - SERVICING and MAINTENANCE

BEFORE ATTEMPTING ANY MAINTENANCE TASK, ISOLATE THE APPLIANCE AT THE MAIN SUPPLY. TAKE STEPS TO ENSURE THAT IT MAY NOT BE INADVERTENTLY SWITCHED ON.

3.1 ELECTRICAL CONTROL GEAR

The mains terminals are located at rear of unit. The contactor(s) are contained within box at front.

To gain access, open door and remove cover panel behind.

The control thermostat(s) and neon lamps are mounted on the fascia panel, which is secured by four fixings.

3.2 NEON INDICATOR LAMPS

These must be replaced by new lamps in event of failure.

To replace a faulty lamp, first remove fascia panel and pull off push-on terminals. Remove lamp by undoing fixing nut at rear.

3.3 THERMOSTATS

The fryer has two thermostats.

The adjustable control thermostat is mounted upon control panel.

The safety thermostat is located within the element box. It has a fixed setting and manual re-set button at rear of element box. In the event of control thermostat failure and resultant overheating of frying medium, safety thermostat will trip supply to elements before oil temperature becomes dangerous.

To restore circuit having rectified the fault, it is necessary to press the re-set button. This is situated within the turret which projects through element box rear. The oil must be allowed to cool to enable safety thermostat to be re-set.

A defective safety or control thermostat cannot be repaired and must be replaced. The capillary tubes pass through pan wall and are sealed with small glands which must not be overtightened. The phial must be fixed in position within pan before tightening gland. The phial tip should protrude from protective tube by 33mm. Thermostat capillary tube must be covered with sleeve insulation. Safety stat phial should be located centrally within element clip.

3.4 CONTACTOR

This should require little or no maintenance under normal circumstances. After long service, the contacts may become pitted and at that point, new contacts should be fitted.

3.5 ELEMENTS

These are individually replaceable. Access to terminals and fixing nuts is gained upon removing element box cover. When fitting a new element, ensure that sealing gasket is fitted and tighten fixing nut firmly, preferably with the aid of a tubular box spanner or socket.

When re-fitting element box cover, check condition of oil resistant gasket. Do not use excessive force when securing cover as this may deform it and allow oil to enter box.

3.6 CLEANLINESS

To maintain maximum performance, the pan must be kept clean. Periodically, oil must be drained off and the pan should be filled with water and detergent. Boil up contents and drain whilst still hot before flushing out with clean water. Thoroughly dry pan and all fittings before re-filling with oil. The elements can be lifted and hinged backward to gain full access to all surfaces of pan and elements.

3.7 TILT SWITCH

Located in element terminal box, this component should require no maintenance.

SECTION 4 - SPARES

When ordering spares, quote the unit type and serial number. This information will be found on data plate located on cover panel behind door.

An identity label is also provided on front frame.

E3830 WIRING DIAGRAM

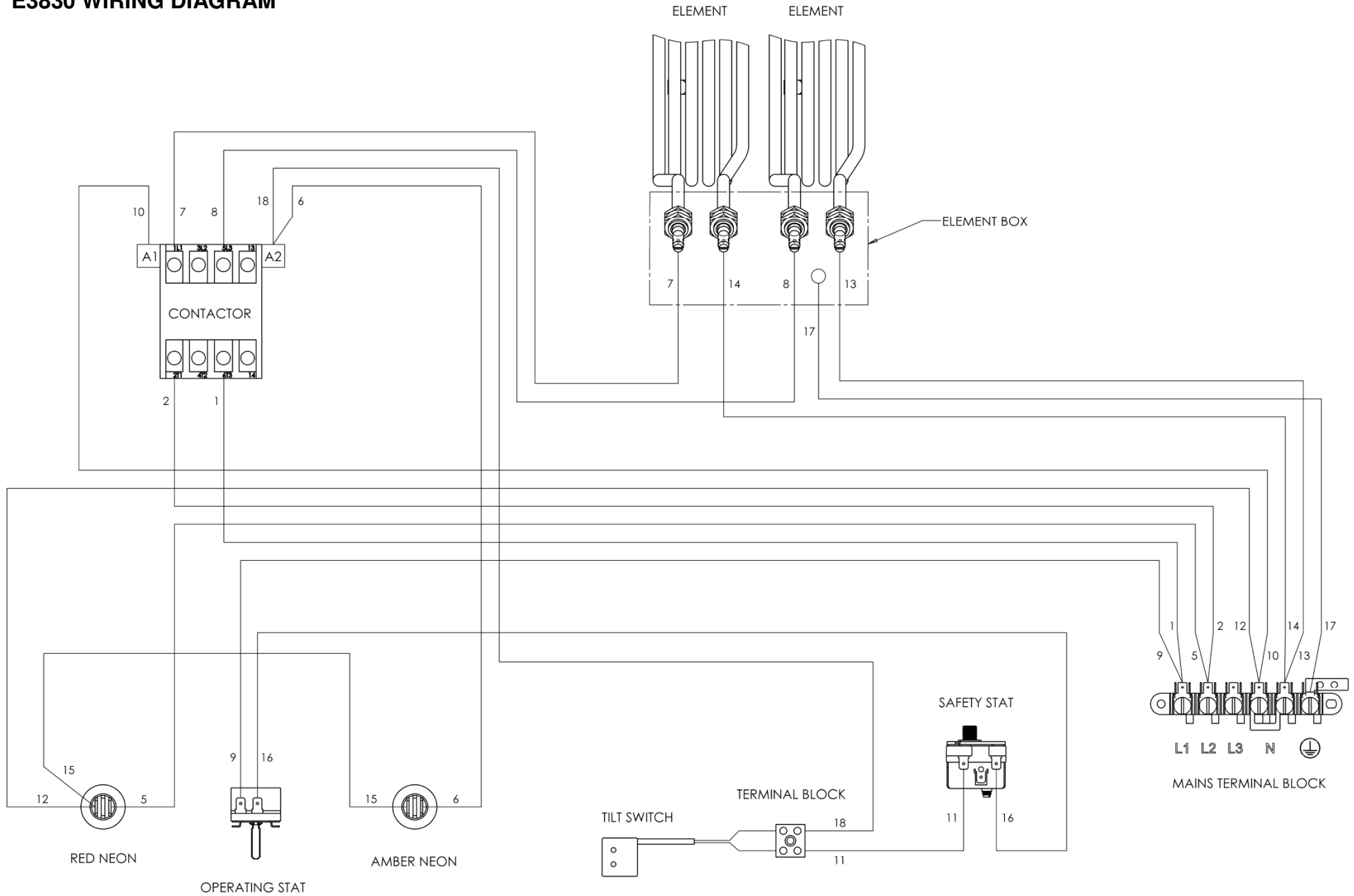

E3830 CIRCUIT DIAGRAM

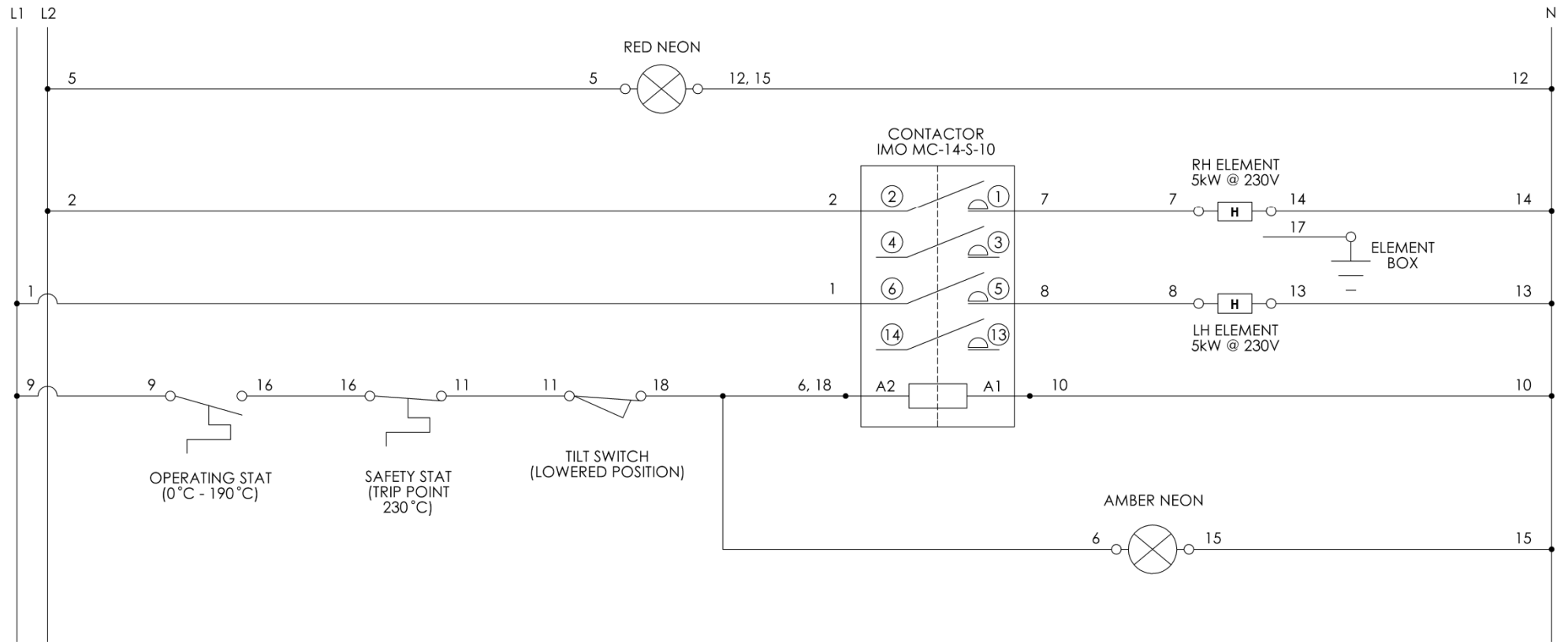

E3860 WIRING DIAGRAM

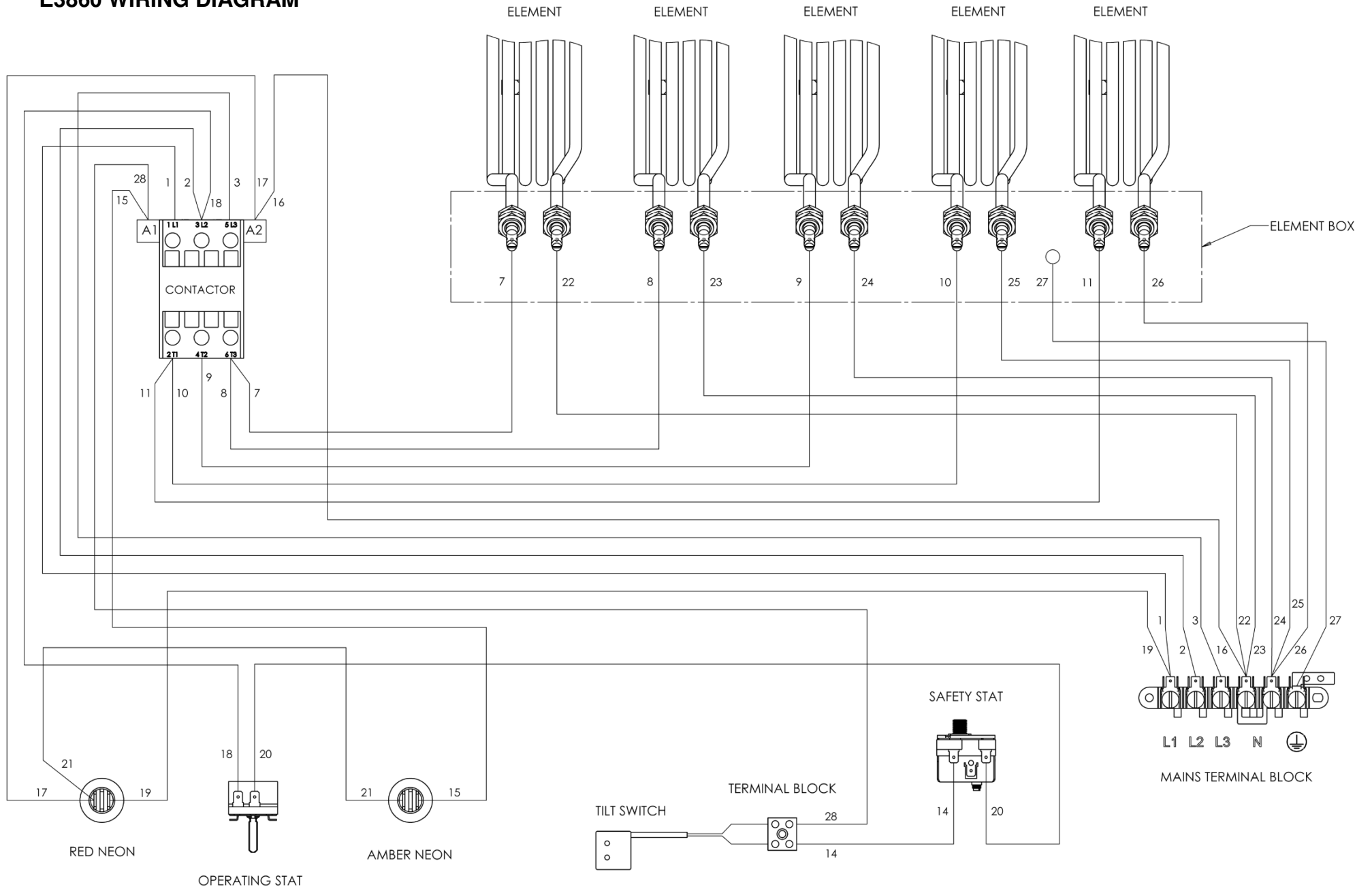

E3860 CIRCUIT DIAGRAM

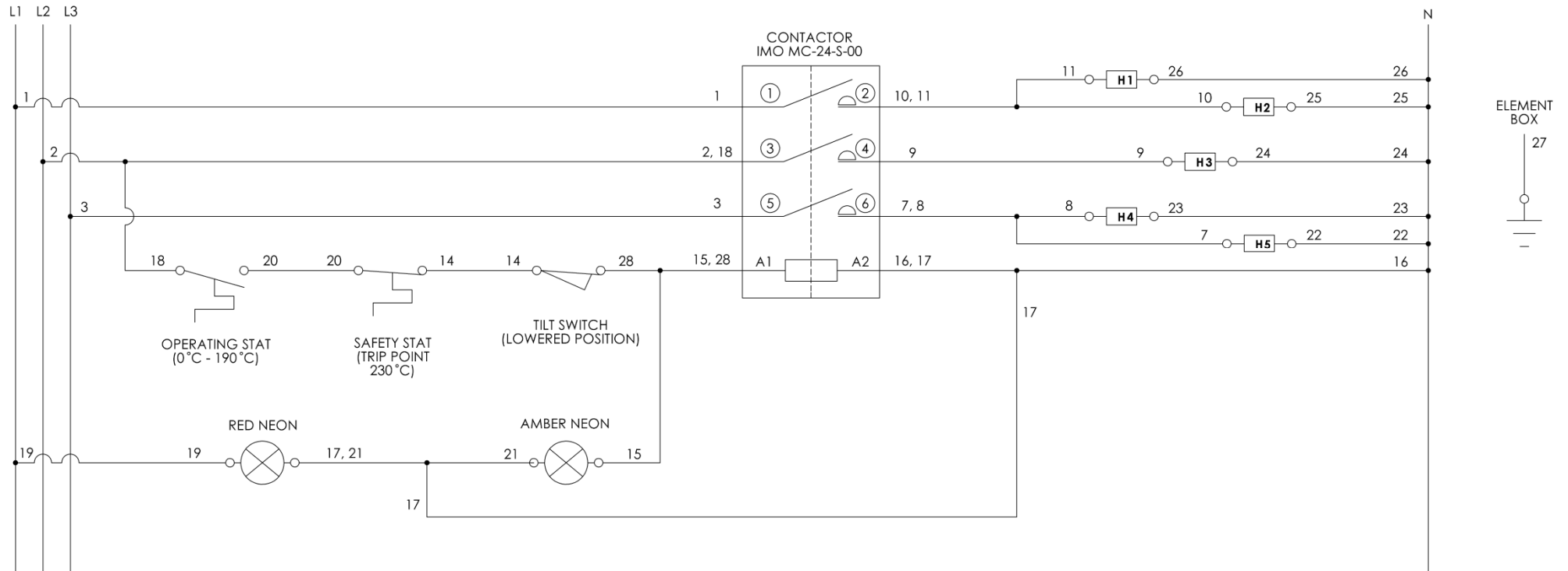

ELEMENT POSITIONS ARE WHEN VIEWED FROM FRONT OF APPLIANCE

- H1 - OUTSIDE LH ELEMENT (3.65kW @ 230V)
- H2 - INSIDE LH ELEMENT (3.65kW @ 230V)
- H3 - CENTRE ELEMENT (3.65kW @ 230V)
- H4 - INSIDE RH ELEMENT (3.65kW @ 230V)
- H5 - OUTSIDE RH ELEMENT (3.65kW @ 230V)

E3865 WIRING DIAGRAM

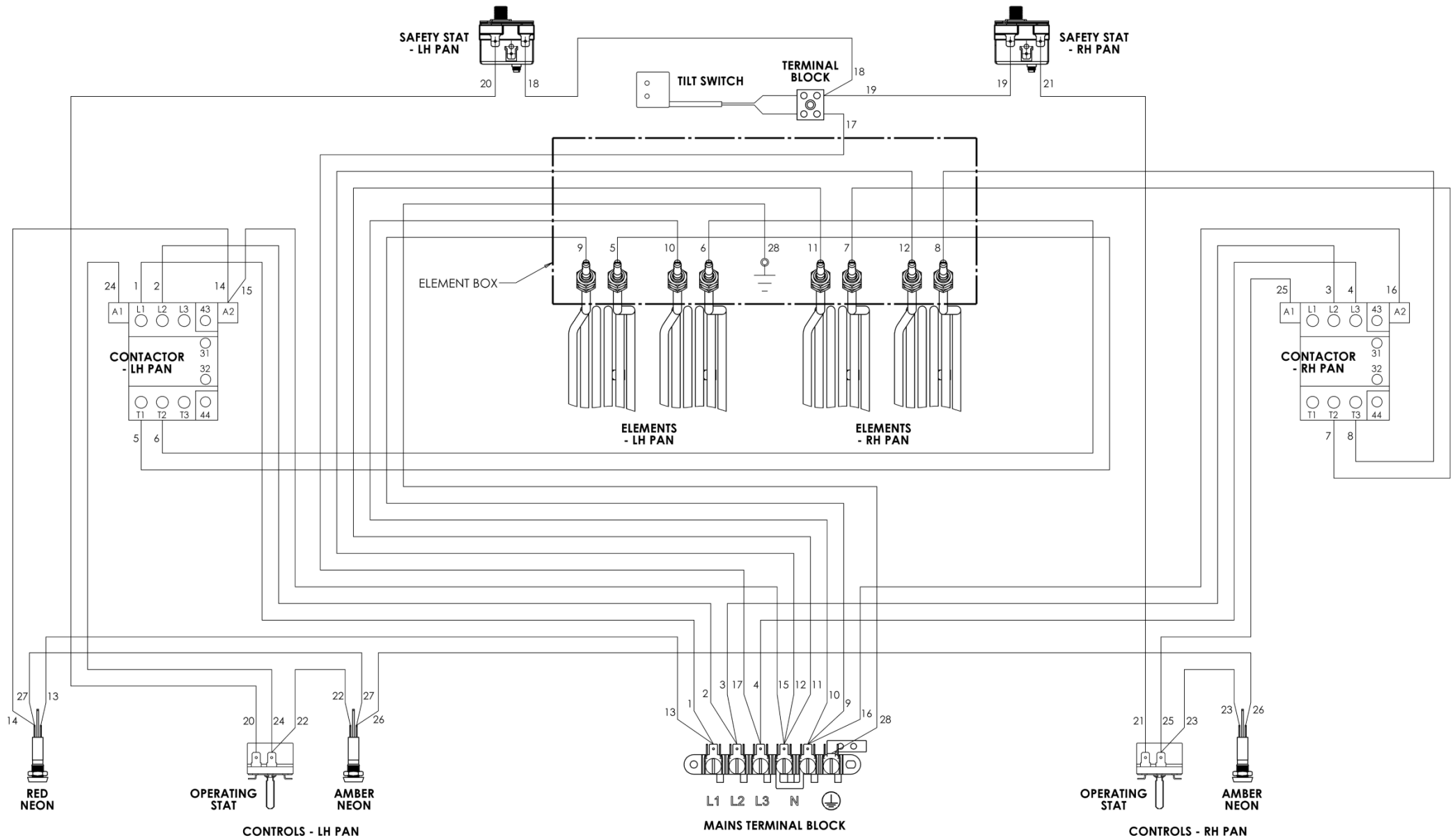

E3865 CIRCUIT DIAGRAM

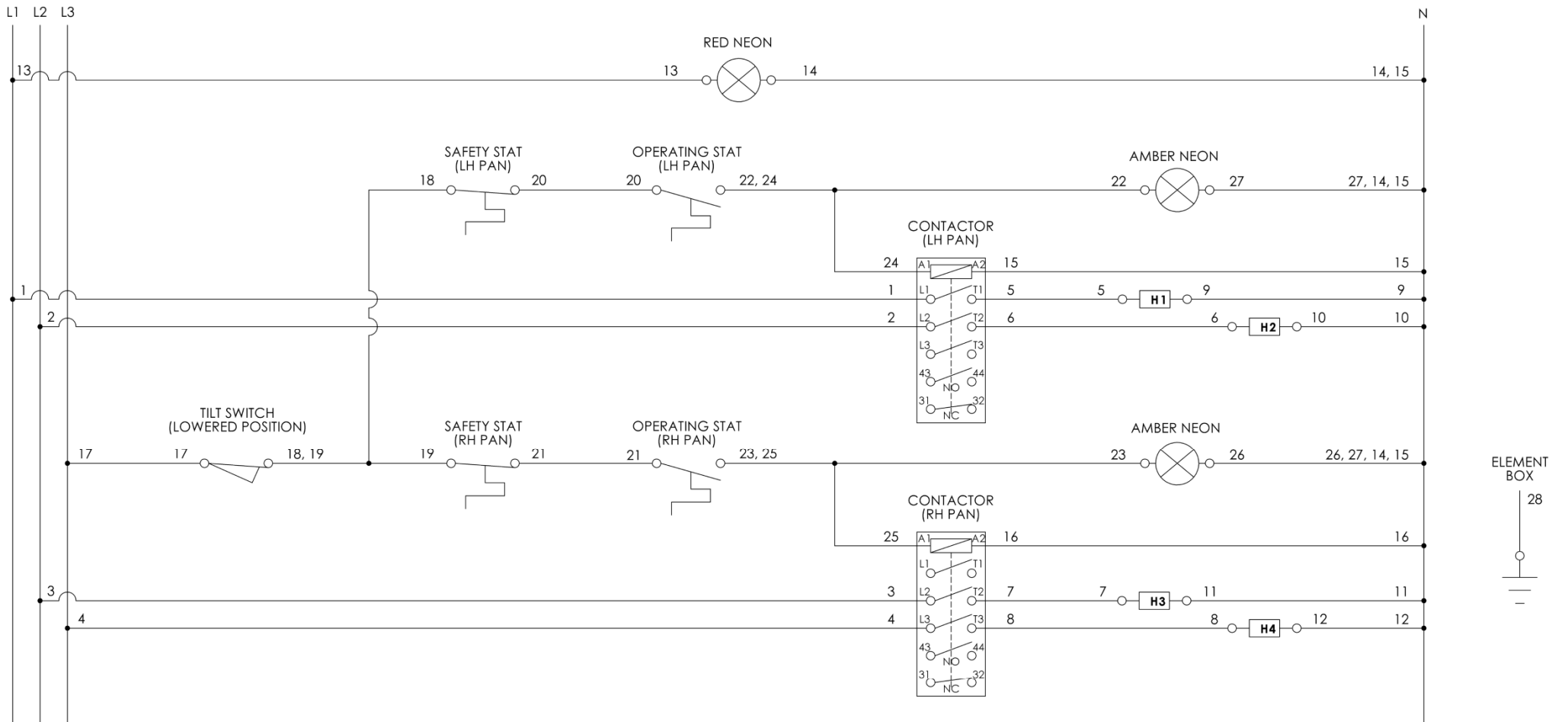

ELEMENT POSITIONS ARE WHEN VIEWED FROM FRONT OF APPLIANCE

- H1 - LH PAN, LH ELEMENT (5.0kW @ 230V)
- H2 - LH PAN, RH ELEMENT (5.0kW @ 230V)
- H3 - RH PAN, LH ELEMENT (5.0kW @ 230V)
- H4 - RH PAN, RH ELEMENT (5.0kW @ 230V)

