

Heated Cupboards

HCP14

**304
STAINLESS
STEEL**

Suitable for all gantry options -
see page 291

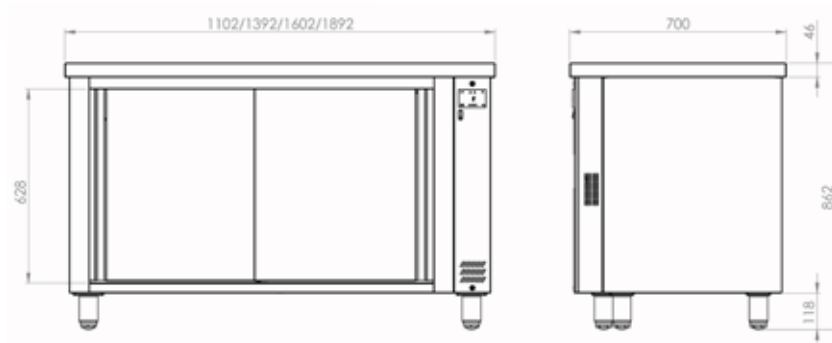

FEATURES

High grade AISI 304 stainless steel exterior & interior

Double skinned insulated doors to improve efficiency

Fan assisted heating

Adjustable legs

1 fixed perforated shelf

TECHNICAL SPECIFICATIONS

Controller: Digital controller with temperature display

Temperature Range: +30°C ~ +72°C

Power Supply: 13amp

MODEL	NO. OF PLATED MEALS	NO. OF PLATES	EXTERNAL DIMENSIONS (H x W x D mm)	POWER CONSUMPTION	WEIGHT (kg)	RRP
HCP11	91	695	860 x 1100 x 700	1450W	80	
HCP14	111	850	860 x 1390 x 700	1450W	94	
HCP16	133	1000	860 x 1600 x 700	1850W	112	
HCP19	155	1200	860 x 1890 x 700	1850W	131	

OPTIONAL EXTRAS

Castors supply & fitted prior to dispatch T6-CASTORKIT6

1

**YEAR
WARRANTY**