



# Cabinet Solutions

Cafeterias • Convenience Stores  
Catering • Concessions



**FDWDE-1X** with accessory 5-shelf multi-purpose rack *pg. 2*



**FSDT-2** with accessory 5-shelf multi-purpose rack (decals shown not available) *pg. 3*



**MDW-1X** in standard *Designer Black* with optional hood with backlit sign cut out on one side (sign included) *pg. 7*



**FSHC-6W1** with standard Silver Gray side panels and top, and accessory food pans *pg. 8*



**FSHC-7-1** with standard Silver Gray side panels and top, and accessory food pans *pg. 9*



**FS2HAC-2PT** Pass-through style with accessory food pans *pg. 10*



## Flav-R-Fresh® Impulse Display Cabinets

A profitable way to create impulse food sales is with the small Flav-R-Fresh® Holding and Display Cabinet. Using separate heat and humidity controls to keep crisp foods crisp and moist foods moist allows you to showcase your products longer using minimum counter space.

- The rounded designed cabinet features tempered glass sides and door for full-view display
- Incandescent light enhances food appeal while safeguarding food products from bulb breakage
- Internal thermometer indicates cabinet temperature
- Single- or double-door opening models provide fast access to food racks
- Food decals and merchandising signs are available to help promote product



**FDWDE-1** with rotating 4-tier rack and accessory pizza pans

### IMPULSE DISPLAY CABINETS

Model* <sup>o</sup>	Description <sup>o</sup>	Dimensions W x D x H <sup>o</sup>	Voltage		Ship Weight
			Single Phase		
<b>FDWDE-1</b>	1 Door w/Circle Rack w/Motor	492 x 530 x 726 mm	240		38 kg
<b>FDWDE-1X</b>	1 Door w/Multi-Purpose Rack	492 x 530 x 726 mm	240		38 kg
<b>FDWDE-2</b>	2 Doors w/Circle Rack	492 x 559 x 726 mm	240		40 kg
<b>FDWDE-2X</b>	2 Doors w/Multi-Purpose Rack	492 x 559 x 726 mm	240		40 kg

- Models FDWDE-1 and FDWDE-2 include rack motor. Models with "X" designator do not have revolving display and are NOT available for retrofit.
- <sup>o</sup>Non-humidified cabinet available. Unit will only operate in dry mode.
- <sup>o</sup>Rack listed is included with unit. Other racks available.
- Height includes standard 25 mm legs.

**All Impulse Display Cabinet Models Feature:**

**Cabinet Opening Dimensions:** 400 W x 502 H mm.

**Door Hinges: Control Side:** Left-hand side.

**Customer Side (Two-Door Models Only):** Right-hand side.

**Max. Pizza Pan Size:** 381 mm diameter.

**Water Tank Capacity for Humidity System:** 2 liters.

**Cord Location:** 1829 mm. Facing controls, left-hand side panel, lower right corner.

**WATER QUALITY REQUIREMENTS – PAGE 11**

#### OPTIONS (available at time of purchase only)

**Designer Colors – Non-standard colors are non-returnable – Clear Anodized Aluminum Standard –**

<b>RED</b>	Warm Red
<b>BLACK</b>	Black
<b>GRAY</b>	Gray Granite
<b>WHITE</b>	White Granite
<b>NAVY</b>	Navy Blue
<b>GREEN</b>	Hunter Green
<b>COPPER</b>	Antique Copper

#### ACCESSORIES

<b>FDWD-LEGS</b>	102 mm Adjustable Legs (102-127 mm)
<b>COUPLING</b>	Motorless Rack Coupling for FDWDE-1X and -2X models (select Circle Rack or Pretzel Tree)
<b>FDWD4TCRR</b>	4-Tier Circle Rack with Pizza Pan Retainers (requires Coupling for -1X or -2X models)
<b>FDWD4SMP</b>	4-Shelf Multi-Purpose Rack (each shelf – 346 W x 321 D mm)
<b>FDWD3TPT</b>	3-Tier Pretzel Tree (requires Coupling for -1X or -2X models)

**RACKS – PAGE 6**

**COLORS AND FINISHES – PAGE 11**



#### OPTIONS (available at time of purchase only)

<b>FDWD-6FRT</b>	152 mm Merchandising Display Sign Holder for control side only (includes Metal Holder only). Available in all Designer Colors to match your unit (Black is standard). Adds 29 mm to height of unit. Requires one (1) Sign – 491 W x 157 H x 2 D mm (not included)
<b>FDWD-6SIGN</b>	162 mm One-Sided Merchandising Display Sign Holder (includes Metal Holder and Window) – <b>one per side, three maximum.</b> Available in all Designer Colors to match your unit (Black is standard). Adds 32 mm to height of unit. Requires one (1) Sign – 491 W x 159 H x 1.59 D mm (not included)
<b>FDWD-DIS</b>	76 mm One-Sided Merchandising Display Sign Holder (includes Metal Holder and Window) – <b>one per side, three maximum.</b> Available in all Designer Colors to match your unit (Black is standard). Adds 32 mm to height of unit. Requires one (1) Sign – 484 W x 83 H x 2 D mm (not included)

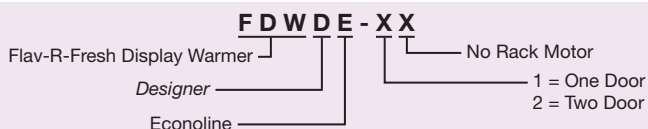

## Flav-R-Savor® Holding & Display Cabinets

Balancing a precise combination of heat and humidity, the Hatco Flav-R-Savor® Cabinets provide an attractive showcase for hot food displays and generate impulse sales. A complete range of cabinet sizes, door options and rack types allows for perfect merchandising of food products such as pizza, fried foods, bakery items, sandwiches and more.

- Full-view display with tempered glass sides and door provide maximum heat retention
- Controlled heat and humidity for longer holding times
- 3-liter stainless steel water reservoir provides all day moisture
- Low-water protection prevents heating element burnout and alerts operator to low-water condition
- Revolving or stationary display racks
- Available in two heights with single- or double-sided opening models
- Fluorescent lights with clear plastic cover help showcase food product



**FSD-2X** with 3-tier pan rack and accessory and food pans



**FSDT-1** with 4-tier circle rack, optional *Designer* Black color and accessory 102 mm legs and food pans

### DISPLAY CABINETS

Model* <sup>o</sup>	Description <sup>o</sup>	Dimensions W x D x H	Voltage Single Phase	Watts	Ship Weight
<b>Standard</b>					
<b>FSD-1</b>	1 Door w/3-Tier Circle Rack	569 x 612 x 699 mm	240	1440	50 kg
<b>FSD-1X</b>	1 Door w/3-Tier Pan Rack	569 x 612 x 699 mm	240	1440	50 kg
<b>FSD-2</b>	2 Doors w/3-Tier Circle Rack	569 x 642 x 699 mm	240	1440	52 kg
<b>FSD-2X</b>	2 Doors w/3-Tier Pan Rack	569 x 642 x 699 mm	240	1440	51 kg
<b>Tall</b>					
<b>FSDT-1</b>	1 Door w/4-Tier Circle Rack	569 x 612 x 826 mm	240	1440	54 kg
<b>FSDT-1X</b>	1 Door w/4-Tier Pan Rack	569 x 612 x 826 mm	240	1440	54 kg
<b>FSDT-2</b>	2 Doors w/4-Tier Circle Rack	569 x 642 x 826 mm	240	1440	55 kg
<b>FSDT-2X</b>	2 Doors w/4-Tier Pan Rack	569 x 642 x 826 mm	240	1440	52 kg

\* Models FSD-1, FSD-2, FSDT-1 and FSDT-2 include rack motor. Models with "X" designator do not have revolving display and are NOT available for retrofit.

<sup>o</sup> Rack listed is included with unit. Other racks available.

<sup>o</sup> Non-humidified cabinet available. Unit will only operate in dry mode.

#### All Display Cabinet Models Feature:

Cabinet Opening Dimensions: Standard Models: 483 W x 473 H mm.

Tall Models: 483 W x 603 H mm.

Door Hinges: Control Side: Left-hand side.

Customer Side (Two-Door Models Only): Right-hand side.

Max. Pan Size: 483 mm diameter.

Water Tank Capacity for Humidity System: 3 liters.

Cord Location: 1829 mm. Facing controls, left-hand side panel, lower right corner.

#### OPTIONS AND ACCESSORIES – PAGE 4

#### DECORATIVE KIT – PAGE 5

#### RACKS – PAGE 6

#### WATER QUALITY REQUIREMENTS – PAGE 11

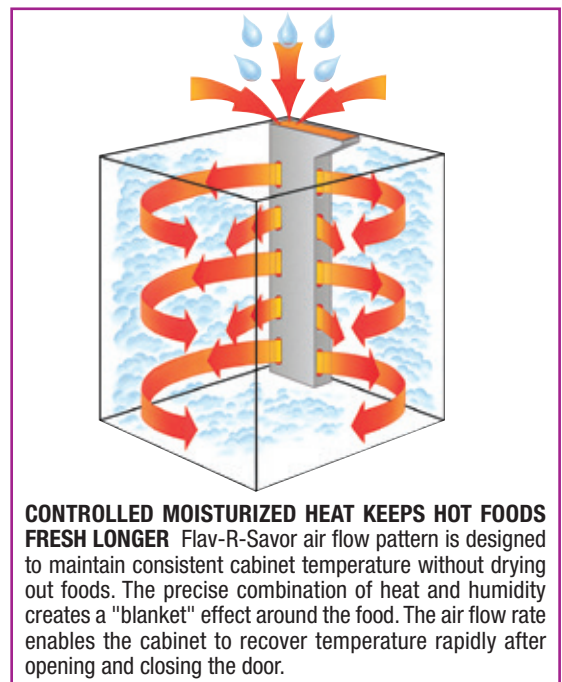

FSDT - XX	
Flav-R-Savor Display Cabinet	No Rack Motor
No Character = Standard	1 = One Door
T = Tall	2 = Two Door



FSDT-1 with 4-tier circle rack, optional sign holders (signs not included) and accessory food pans

**OPTIONS** (available at time of purchase only)

**Designer Colors – Non-standard colors are non-returnable – Clear Anodized Aluminum Standard –**

<b>RED</b>	Warm Red
<b>BLACK</b>	Black
<b>GRAY</b>	Gray Granite
<b>WHITE</b>	White Granite
<b>NAVY</b>	Navy Blue
<b>GREEN</b>	Hunter Green
<b>COPPER</b>	Antique Copper
<b>THERM</b>	Mechanical Controls
<b>FSD7SIGN</b>	191 mm Merchandising Display Sign Holder (includes Metal Holder and Window) – <b>one per side, three maximum.</b> Available in all <i>Designer</i> Colors to match your unit (Black is standard). Adds 32 mm to height of unit. Requires one (1) Sign – 572 W x 191 H x 2 D mm (not included)

**ACCESSORIES**

<b>F-LEGS-4</b>	102 mm Adjustable Legs
<b>COUPLING</b>	Motorless Rack Coupling for FSD-1X, FSD-2X, FSDT-1X & FSDT-2X models (select appropriate Circle Rack)
<b>RACK – FSD ONLY –</b>	
<b>FSD5SMP</b>	5-Shelf Multi-Purpose Rack (each shelf – 457 W x 406 D mm)
<b>FSD3TCR</b>	3-Tier Circle Rack with Pizza Pan Retainers (requires Coupling for -1X or -2X models)
<b>FSD3TPR</b>	3-Tier Pan Rack (accommodates Half-Size Sheet Pans – not included)
<b>RACKS – FSDT ONLY –</b>	
<b>FSDT7SMP</b>	7-Shelf Multi-Purpose Rack (each shelf – 457 W x 406 D mm)
<b>FSDT4TCR</b>	4-Tier Circle Rack with Pizza Pan Retainers (requires Coupling for -1X or -2X models)
<b>FSDT5TCR</b>	5-Tier Circle Rack with Pizza Pan Retainers (requires Coupling for -1X or -2X models)
<b>FSDT4TPR</b>	4-Tier Pan Rack (accommodates Half-Size Sheet Pans – not included)
<b>FSDT3SAR</b>	3-Shelf Angle Rack (15° angle shelves). Each shelf – 457 W x 413 D mm
<b>FSDT3TPT</b>	3-Tier Pretzel Tree (requires Coupling for -1X or -2X models)

**DECORATIVE KIT – 5**  
**RACKS – PAGE 6**  
**COLORS AND FINISHES – PAGE 11**

## Flav-R-Savor® Decorative Kit for FSD and FSDT Models only

Transform your Hatco Flav-R-Savor® Holding & Display Cabinet from a "heated box" into a Designer Merchandiser with a variety of simple accessory additions. Create a new look and feel to your décor.

- The curved hinged header allows easy access to controls and water fill cup, and gives a great area to brand your food product with a magnetic sign (sign not included)
- All decorative pieces come standard in Designer Black powdercoat, with additional Designer colors available
- Curved inset panels enhance the overall look
- The base skirt completes the transformation and gives additional branding area. Available in flat or curved panels for front and/or back of unit
- Signs not included

### OPTIONS (available at time of purchase only – additional lead time required)

#### Designer Colors – Non-standard colors are non-returnable –

<b>RED</b>	<b>WR</b>	Warm Red
<b>BLACK</b>	<b>BK</b>	Black
<b>GRAY</b>	<b>GG</b>	Gray Granite
<b>WHITE</b>	<b>WG</b>	White Granite
<b>NAVY</b>	<b>NB</b>	Navy Blue
<b>GREEN</b>	<b>HG</b>	Hunter Green
<b>COPPER</b>	<b>AC</b>	Antique Copper

### ACCESSORIES

#### Side Insets – Must choose Designer Color – Black Standard –

<b>FSD-INSET1-BK</b> ②	Two (2) Crescent Inset Panels for FSD Models – Black
<b>FSD-INSET2-BK</b> ②	Two (2) Wave Inset Panels for FSD Models – Black
<b>FSDT-INSET1-BK</b> ②	Two (2) Crescent Inset Panels for FSDT Models – Black
<b>FSDT-INSET2-BK</b> ②	Two (2) Wave Inset Panels for FSDT Models – Black

#### Top Covers – Must choose Designer Color – Black Standard –

<b>FSD-CTLH-BK</b> ①	Curved Hinged Header on control side for FSD and FSDT models – Black
<b>FSD-CUSH-BK</b> ②	Curved Header on non-control side for FSD and FSDT models – Black

#### Base Skirts – Requires 102 mm Adjustable Legs (not included) – Must choose

<b>FSD-SQB-BK</b> ②⑤⑦	One (1) Flat Front Panel, two (2) Flat Side Panels and one (1) Flat Back Panel for FSD and FSDT models – Black
<b>FSD-1CB-BK</b> ②⑤⑦	One (1) Curved Front Panel, two (2) Flat Side Panels and one (1) Flat Back Panel for FSD and FSDT models – Black
<b>FSD-2CB-BK</b> ②⑤④	One (1) Curved Front Panel, two (2) Flat Side Panels and one (1) Curved Back Panel for FSD and FSDT models – Black
<b>F-LEGS-4</b>	102 mm Adjustable Legs for FSD and FSDT models

### COLORS AND FINISHES – PAGE 11

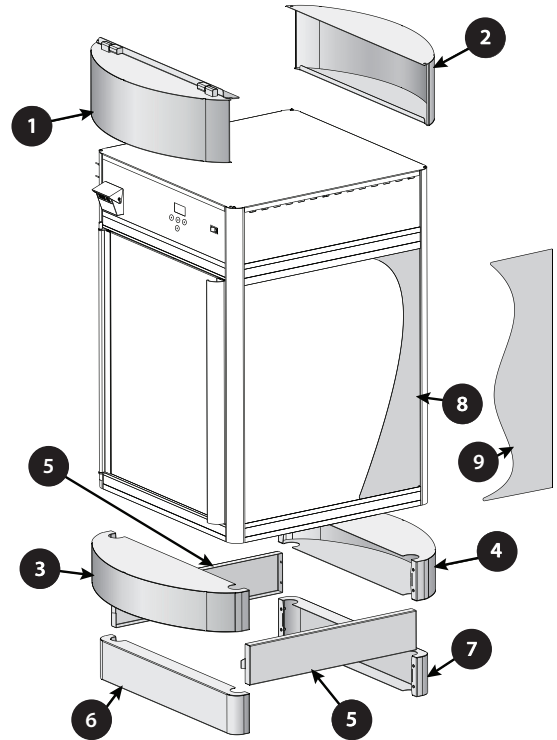

FSDT-1 with 4-tier circle rack and full Decorative Kit (signs not included)

## Display Rack Selections

### Racks for FDWDE Models (Page 2)

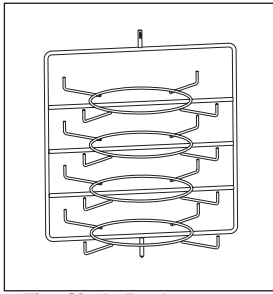

**4-Tier Circle Rack  
FDWD4TCRR**  
(Max. 381 mm dia. pans)  
(83 mm opening)

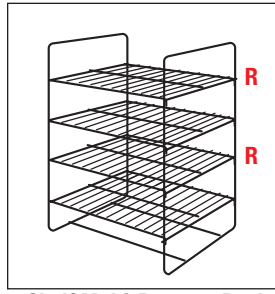

**4-Shelf Multi-Purpose Rack  
FDWD4SMP**  
(Max. 457 x 330 mm Half-Size  
Sheet Pans – FDWD-2X only)  
(95 mm opening)

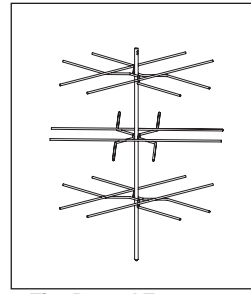

**3-Tier Pretzel Tree  
FDWD3TPT**  
(149 mm opening)

### Racks for FSD/FSDT Models (Page 3)

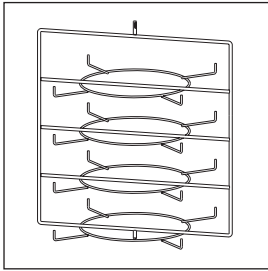

**FSDT 4-Tier Circle Rack  
FSDT4TCR**  
(Max. 483 mm dia. pans)  
(117 mm opening)

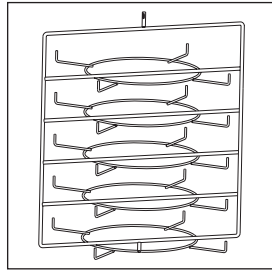

**5-Tier Circle Rack  
FSDT5TCR**  
(Max. 483 mm dia. pans)  
(98 mm opening)

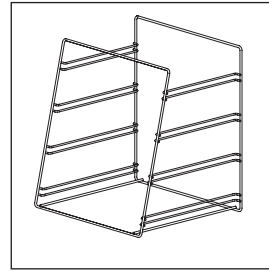

**FSDT 4-Tier Pan Rack  
FSDT4TPR**  
(Max. 457 x 330 mm  
Half-Size Sheet Pans)  
(89 mm opening)

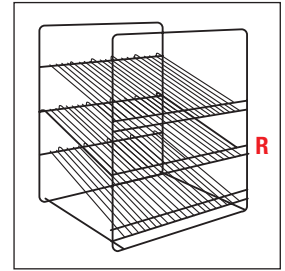

**FSDT 3-Shelf Angle Rack  
FSDT3SAR**  
(89 mm opening)

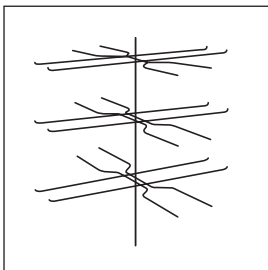

**FSDT 3-Tier Pretzel Tree  
FSDT3TPT**  
(149 mm opening)

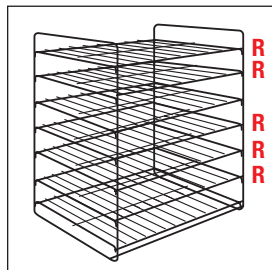

**FSDT 7-Shelf Multi-Purpose  
Rack FSDT7SMP**  
(Max. 457 x 330 mm  
Half-Size Sheet Pans)  
(64 mm opening)

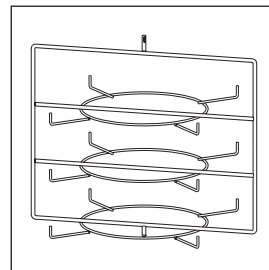

**FSD 3-Tier Circle Rack  
FSD3TCR**  
(117 mm opening)

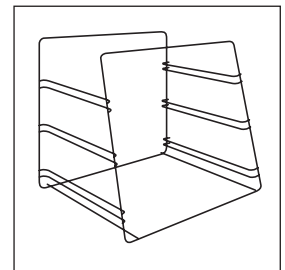

**FSD 3-Tier Pan Rack  
FSD3TPR**  
(89 mm opening)

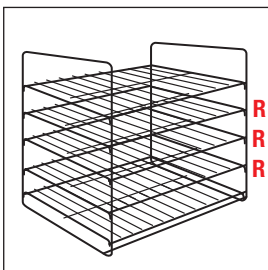

**FSD 5-Shelf  
Multi-Purpose Rack  
FSD5SMP**  
(64 mm opening)

**R** Removable Shelves

## Mini Display Warmers

The Hatco Mini Display Warmer is perfect for cookies, pastries, wrapped or boxed sandwiches or any other product that does not require humidity. Hot air circulates throughout the entire cabinet, keeping food at safe-serving temperatures. The small footprint takes up little of your valuable counterspace while merchandising your breakfast, lunch or dinner offerings.



Magnetically adjustable shelves provide flexibility for a variety of product choices

- Magnetically adjustable shelves allow horizontal or slanted displays
- Tempered glass sides and incandescent light showcase your food
- Thermostatic control with rocker switch
- Field reversible door hinge location
- Available as a 1-door or a 2-door pass-through model
- Doors may be field converted to any side
- Optional black hood with backlit graphic sign cutout that can be rotated in field to face any side (sign included)

**MDW-1X** in standard *Designer Black* with optional hood with backlit sign cut out on one side (sign included)



### MINI DISPLAY WARMERS – NON-HUMIDIFIED

Model	Description	Dimensions W x D x H	Voltage		Ship Weight
			Single Phase		
<b>MDW-1X</b>	1 Door w/3 Shelves	400 x 432 x 646 mm	230		21 kg
<b>MDW-2X</b>	2 Doors w/3 Shelves	400 x 465 x 646 mm	230		24 kg

**All Non-Humidified Mini Display Warmer Models Feature:**

Cabinet Opening Dimensions: 315 W x 396 H mm.

Door Hinges: **Control Side:** Left-hand side.

**Customer Side (Two-Door Models Only):** Right-hand side.

Cord Location: Facing controls, lower right corner.

### OPTIONS (available at time of purchase only)

**Designer Colors for Posts, Base and Top Trim – Non-standard colors are non-returnable – Black Standard –**

<b>RED</b>	Warm Red
<b>BLACK</b>	Black
<b>GRAY</b>	Gray Granite
<b>WHITE</b>	White Granite
<b>NAVY</b>	Navy Blue
<b>GREEN</b>	Hunter Green
<b>COPPER</b>	Antique Copper
<b>BCKLIT-MDW</b>	Hood with Backlit Sign cut out on one side (Sign included) – Black only

### ACCESSORIES

**MDW-TRAY** Aluminum Tray – 314 W x 314 D x 6 H mm

### COLORS AND FINISHES – PAGE 11

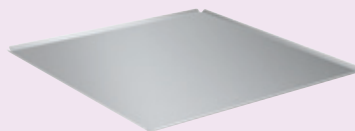

**MDW-TRAY** Accessory





## Flav-R-Savor® Portable Holding Cabinets

Prepare food in advance of peak serving periods and safely hold it at optimum serving temperatures with the Flav-R-Savor® Portable Holding Cabinet. Thermostatically-controlled heat and humidity allows you to hold product for hours.

- Thermostatically-controlled heat and humidity holds hot food at optimum serving temperatures longer
- Allows preparation of food in advance of peak serving periods
- Accommodates Gastronorm pans
- Electrical components, controls, water reservoir and digital temperature readout are located at the top for easy access
- Reduced height – less than 762 mm high and wider footprint for increased capacity
- Stacking kit available

- Insulated side walls, field reversible glass doors, large swivel casters with wheel locks and 1829 mm recessed cord & plug set are standard



FSHC-6W2 with accessory food pans

### LOW PROFILE HOLDING CABINETS

Model	Description	Dimensions W x D x H*	Voltage		Watts	Ship Weight
			Single Phase	Watts		
FSHC-6W1	1 Door	645 x 751 x 816 mm	240	1697	76 kg	
FSHC-6W2*	2 Doors	645 x 811 x 816 mm	240	1697	82 kg	

- \* Height includes standard casters.
- \* FSHC-6W2 is a two-door pass-through single cabinet, not two units stacked.

#### All Low Profile Holding Cabinet Models Feature:

Cabinet Opening Dimensions: 546 W x 483 H mm.

Top Surface Dimensions: 645 W x 657 D mm.

Models Shipped with: A 1829 mm cord & plug set, 102 mm diameter casters (with 130 mm clearance) and six (6) sets of adjustable angle slides.

Pan Capacity: Six (6) 457 W x 660 D mm sheet pans or six (6) 2/1 Gastronorm pans on 76 mm centers; eleven (11) 457 W x 660 D mm sheet pans<sup>⌘</sup>; eleven (11) 2/1 Gastronorm pans on 38 mm centers<sup>⌘</sup>; or twelve (12) 508 W x 305 D x 64 H mm hotel pans<sup>⌘</sup>.

Water Tank Capacity for Humidity System: 3 liters.

Cord Location: Back of unit, upper right side.

<sup>⌘</sup> With purchase of extra pan slides.

### WATER QUALITY REQUIREMENTS – PAGE 11

#### OPTIONS (available at time of purchase only)

Colors (Side Panels) – Non-standard colors are non-returnable – Silver Gray Standard – BLACK Designer Black

SS Stainless Steel

Colors (Top) – Non-standard colors are non-returnable – Silver Gray Standard – BLACK

SS Stainless Steel

6W-SS-DR Stainless Steel Door in lieu of Glass Door

HD-SS-DR Heavy-Duty Stainless Steel Door with Positive Latch Handle

6W1-LPCAST 51 mm Low Profile Locking Casters in lieu of standard Casters (51 mm diameter with 76 mm clearance – overall height is 756 mm)

6W1-STACK Silver Gray Stack Hardware mounted to top of Cabinet for two (2) FSHC-6W1 units in lieu of Casters

CORDWIND Bracket for holding Cord during transport

#### ACCESSORIES

6W1-SLIDE Extra Pan Slides

### COLORS AND FINISHES – PAGE 11



6W1-SLIDE Accessory

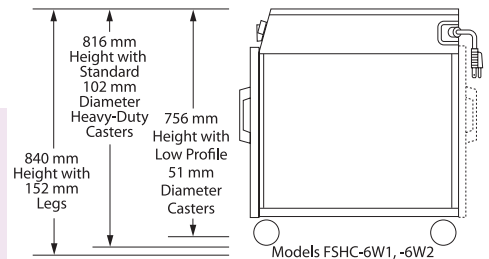

Models FSHC-6W1, -6W2

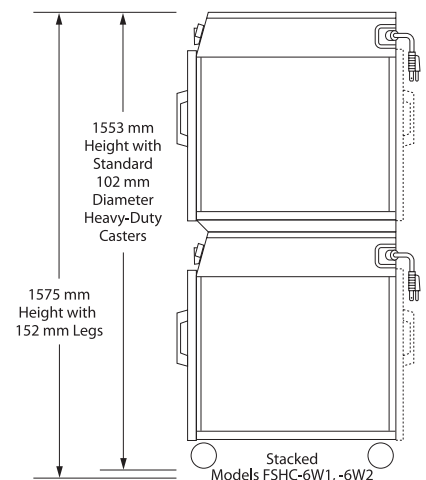

Stacked Models FSHC-6W1, -6W2





## Flav-R-Savor® Humidified Portable Holding Cabinets

Prepare food in advance of peak serving periods and safely hold it at optimum serving temperatures with the Flav-R-Savor® Portable Holding Cabinet. Thermostatically-controlled heat and humidity allows you to hold product for hours.

- Thermostatically-controlled heat and humidity holds hot food at optimum serving temperatures longer
- Allows preparation of food in advance of peak serving periods
- Accommodates Gastronorm pans
- Electrical components, controls, water reservoir and digital temperature readout are located at the top for easy access
- Insulated side walls, field reversible glass doors, large swivel casters with wheel locks and 1829 mm recessed cord and plug are standard
- Stacking kit available



**FSHC-7-1** with standard 102 mm casters and accessory food pans

### PORTABLE HOLDING CABINETS

Model*	Description	Dimensions W x D x H*	Voltage Single Phase	Watts	Ship Weight
<b>FSHC-7-1</b>	1 Door	578 x 753 x 892 mm	240	1697	79 kg
<b>FSHC-7-2*</b>	2 Doors	578 x 812 x 892 mm	240	1697	82 kg

- \* Seven (7) slides on each side. Sheet pans not included. 6-shelf multi-purpose rack can be substituted for angle slides.
- Height includes standard casters.
- \* FSHC-7-2 is a two-door pass-through single cabinet, not two units stacked.

**All Portable Holding Cabinet Models Feature:**

**Cabinet Opening Dimensions:** 470 W x 559 H mm.

**Top Surface Dimensions:** 575 W x 657 H mm.

**Models Shipped with:** A bracket for holding cord during transport (FSHC-7-1 unit only), 102 mm diameter casters (with 130 mm clearance) and seven (7) sets of adjustable angle slides for 457 W x 660 D mm pans or 305 W x 508 D mm pans.

**Pan Capacity:** Seven (7) 457 W x 660 D mm sheet pans on 76 mm centers; seven (7) 508 W x 305 D x 64 H mm<sup>2</sup> hotel pans; or seven (7) 1/1 Gastronorm pans<sup>2</sup>.

**Water Tank Capacity for Humidity System:** 3 liters.

**Cord Location:** A 1829 mm cord & plug set, back of unit, upper right side.

**WATER QUALITY REQUIREMENTS – PAGE 11**

### OPTIONS (available at time of purchase only)

**Colors (Side Panels) – Non-standard colors are non-returnable – Silver Gray Standard –**

<b>BLACK</b>	Designer Black
<b>SS</b>	Stainless Steel

**Colors (Top) – Non-standard colors are non-returnable – Silver Gray Standard –**

<b>BLACK</b>	Designer Black
<b>SS</b>	Stainless Steel

**SS-DR** Stainless Steel Door in lieu of Glass Door

**HD-SS-DR** Heavy-Duty Stainless Steel Door with Positive Latch Handle

**LPCAST** 51 mm Low Profile Casters in lieu of standard Casters (51 mm diameter with 76 mm clearance – overall height is 832 mm)

**4LEGS** 102 mm Adjustable Legs in lieu of standard Casters

**6SS** 152 mm Stainless Steel Legs in lieu of standard Casters

**7-1-STACK** Silver Gray Stacking Hardware mounted to top of Cabinet for two (2) FSHC-7-1 units in lieu of Casters

**CORDWIND** Bracket for holding Cord during transport

### ACCESSORIES

<b>SLIDEWIRE</b>	Wire Shelf
------------------	------------

**COLORS AND FINISHES – PAGE 11**

**SLIDEWIRE  
Accessory**

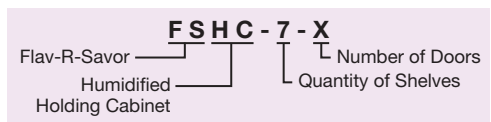
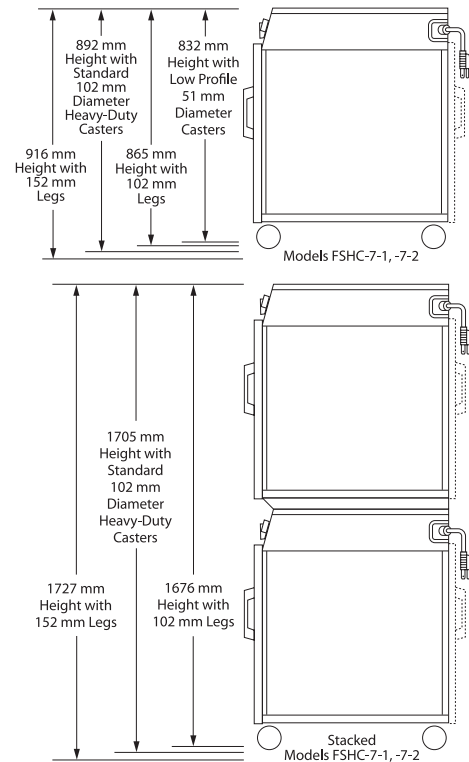
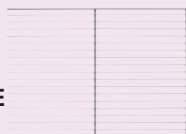



## Flav-R-Savor® Heated Air Curtain Cabinets

The patented Flav-R-Savor® Heated Air Curtain Cabinet effectively and safely holds hot food hot without the use of doors, allowing immediate access to product. Warm air at the front of the cabinet is forced downward, through the ducts above the opening, forming a “curtain” of heated air. A portion of the heated air is drawn toward the rear of the cabinet, warming each pan.

- Perfect for holding wrapped or sealed product like tortillas, burritos and ribs, as well as product on sheet pans like biscuits, hamburger patties and baked potatoes
- The 2-pan pass-through accommodates two (2) full-size sheet pans or four (4) half-size sheet pans; the 4-pan unit accommodates four (4) full-size sheet pans or eight (8) half-size sheet pans
- Easy to use digital controls, a lighted On/Off switch and a 1829 mm cord & plug set



**FS2HAC-4PT** 4-tier pass-through with accessory food pans

### HEATED AIR CURTAIN CABINETS

Model	Description	Dimensions			Voltage	Hz	Watts	Amps	Ship Weight
		W x D x H							
<b>FS2HAC-2PT</b>	2-Tier PT	613	994	468	240	50	2589	12.6	75 kg
<b>FS2HAC-4PT</b>	4-Tier PT	613	994	671	240	50	3389	14	86 kg

**All Heated Air Curtain Cabinet Models Feature:**

Cabinet Opening Dimensions: **FS2HAC-2PT:** 459 x 216 mm.  
**FS2HAC-4PT:** 464 x 411 mm.

**Cord Location:** Top of unit towards the back, left side.

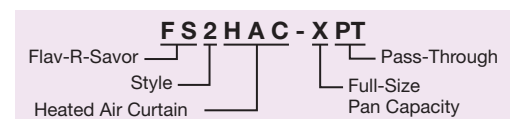



FS2HAC-4PT with accessory  
102 mm legs and food pans

### Water Quality Requirements

Water supply in excess of .75 grains of hardness per liter (GPL) must be treated and softened before being used. Water containing over .75 GPL will decrease the efficiency and reduce the operating life of the unit.

NOTE: Product failure caused by liming or sediment buildup is not covered under warranty.

### Paint Chip Sample Colors

#### DESIGNER COLORS



Warm Red



Black

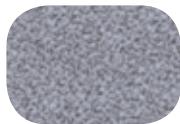

Gray  
Granite



White  
Granite



Navy Blue



Hunter  
Green



Antique  
Copper

**Colors are a representation and may not exactly match our colors.  
Consult factory for possible color matching options on these colors.  
Non-standard colors are non-returnable.**

To order a Hatco Paint Chip & Stone Sample Colors Sheet, visit [www.hatcocorp.com](http://www.hatcocorp.com) / Order Literature / Sales Literature / Sell Sheets.



Scan with web-enabled  
mobile device to visit  
[www.hatcocorp.com](http://www.hatcocorp.com)

## Hatco Corporation

St. George's House | Rearsby Business Park  
Gaddesby Lane | Rearsby | Leicestershire LE7 4YH  
Tel: 01509 260 140 | Fax: 01509 260 151  
[www.hatcocorp.com](http://www.hatcocorp.com) | [sales@gamblefs.co.uk](mailto:sales@gamblefs.co.uk)