

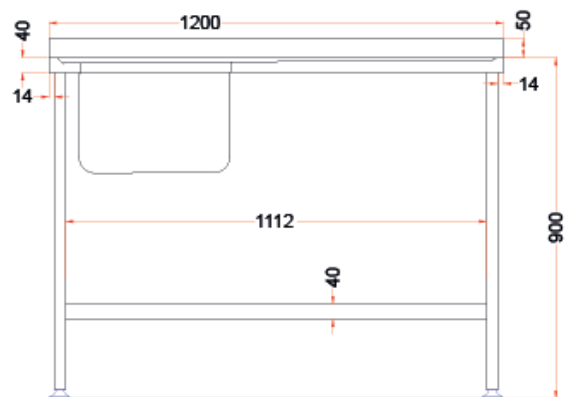

STAINLESS STEEL SINK - DR364 FLATPACK

DIMENSIONS

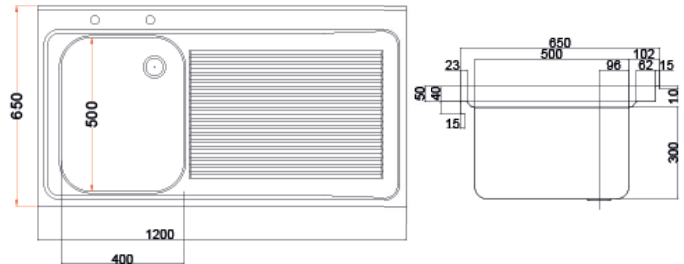

This 1200mm wide flat-packed sink from British manufacturer Holmes features a left side drainer with right side bowl, and is easy to assemble. The practical and hygienic sink boasts a 304 stainless steel construction making it smooth, hygienic and easy to clean whilst offering high resistance to corrosion and staining. The sink is perfect for use in commercial kitchens, allowing you to create practical and hygienic designated washing areas, and features a sturdy undershelf for extra storage.

TECHNICAL DATA

Unpacked height (mm)	900 + 50 upstand
Unpacked width (mm)	1200
Unpacked depth (mm)	650
Weight (kg)	17
Material top	SAE grade 304; EN 1.4301, X5CrNi18-10
Material sub-top	SAE grade 430; EN 1.4016, X6Cr17
Surface finish	Satin
Type of Mounting	Floor
Feet	Adjustable

Property of Holmes