

# Commercial Chest Freezers

SZ282C

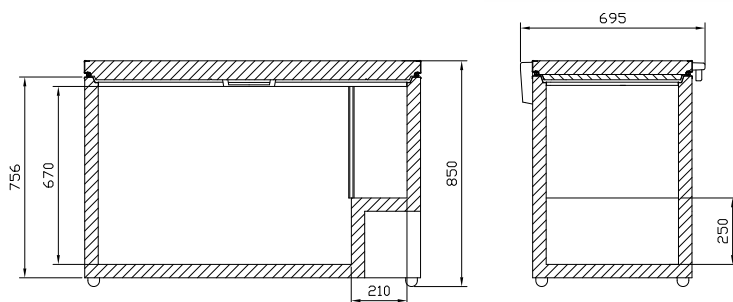

SZ464C



## FEATURES

Anti-corrosion painted plate exterior in white

Aluminium interior

Lock as standard

Depth - including handle 695mm

Drain and drip tray supplied

Skin condenser

Fast freeze function

## TECHNICAL SPECIFICATIONS

Controller: Manual thermostat with digital temperature display

Cooling: Static

Defrost: Manual

Refrigerant: R600a

Climate Class: SN-T

Temperature Range: -18°C ~ -22°C

Power Supply: 13amp

MODEL	GROSS CAPACITY	BASKETS SUPPLIED	MAX. BASKETS	EXT. DIMENSIONS (H x W x D mm)	POWER CONSUMPTION	DECIBELS	WEIGHT (kg)	RRP
SZ181C	187L	1	3	850 x 720 x 695	95W	38dBA	42	
SZ248C	254L	1	6	850 x 920 x 695	130W	38dBA	47	
SZ282C	288L	1	9	850 x 1020 x 695	130W	38dBA	53	
SZ362C	370L	2	12	850 x 1260 x 695	145W	36dBA	58	
SZ464C	475L	2	15	850 x 1560 x 695	190W	37dBA	67	

