

## ELECTRIC 40 LB. FRYERS



Model IFS-40-E  
Immersed Elements

### MODEL NUMBERS

- IFS-40-E Immersed Elements
- IFS-40-EU Tilt-up Elements

### FRYER FEATURES

- 40 lbs. (22 L.) stainless steel frypots with radius formed edges.
- Stainless steel front, doors, sides, basket hanger and frypot.
- Large 14" x 14" (356 x 356) frying area.
- Both immersed and tilt-up serpentine element styles heat oil quickly resulting in less absorption and better tasting food.
- Elements are made of 304 stainless steel and rated at 14 KW.
- "Fire wire" technology provides maximum energy output with lower watt densities, extending the service life of the element.
- Frypot is robotically welded for consistency and leak prevention.
- Cold zone and forward sloping bottom collect and remove debris from the fry area, helping maintain oil quality and making clean-up easier.
- Snap acting thermostat has a 200°F - 400°F (93°C - 204°C) temperature range.
- Recessed bottom for drain accessibility. 1¼" (32) full port drain valve.
- Large nickel plated fry baskets with vinyl-coated handles.
- Double panel door for added strength.
- Full bottom provides structural support.
- Manual or optional programmable computer controls available.
- Durable legs for secure support are standard.
- One year parts and labor warranty. Limited warranty of frypot: Stainless Steel frypot is 5 years pro-rated.



Immersed elements provide a lower cost alternative for electric fryers



Tilt-up elements provide full access to the frypot for cleaning



All measurements in ( ) are metric equivalents



# IMPERIAL ELECTRIC 40 LB. FRYERS

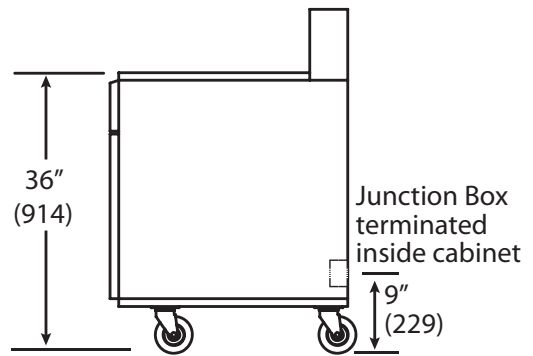
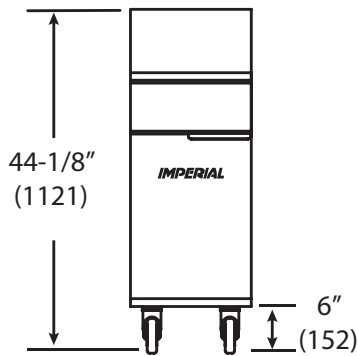
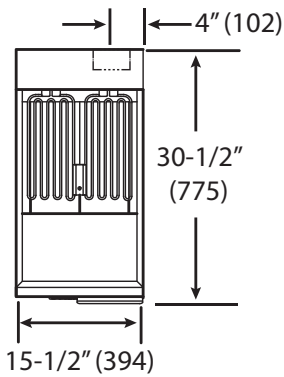

All measurements are  $\pm 1/8"$  (3).

Model	Frypot Description	Element Type	Oil Capacity Lbs. (Liters)	Working Dimensions		Frying Area	Output KW	Ship Weight	
				Width	Depth			Lbs.	(Kg)
IFS-40-E	Stainless steel	Immersed	40 (22)	15 1/2" (394)	30 1/2" (775)	14" x 14" (356 x 356)	14	221	(100)
IFS-40-EU	Stainless steel	Tilt-up	40 (22)	15 1/2" (394)	30 1/2" (775)	14" x 14" (356 x 356)	14	221	(100)
IF-DS	Top draining section with storage cabinet (no filter)	-	-	15 1/2" (394)	30 1/2" (775)	-	-	130	(59)

All measurements in ( ) are metric equivalents.

**Crated Dimensions for floor models:** Height = 35" (889) Depth = 31" (788) Add 2 1/2" (64) to Fryer width.



## STANDARD EXTERIOR FINISH SPECIFICATIONS

Front, sides, door, stub back and basket hanger shall be constructed of stainless steel with welded and finished stainless steel seams. Door shall have a double panel for added strength. Stainless steel legs shall be plate mounted and include non-marking feet.

## FRYPOT SPECIFICATIONS

All precision welded stainless steel vessel shall be constructed of heavy 16 gauge stainless steel. Vessel shall have a large foam area to prevent overflow. All vessel edges shall be radius formed for added durability. Frying area shall be 14" x 14" (356 x 356) with a 40 lbs. (22 L.) oil capacity. Large nickel plated fry baskets shall have vinyl-coated handles for a cool touch.

Immersed and Tilt-up elements shall have a serpentine design to ensure quick heat-up and recovery of desired oil temperature. Elements shall be made of 304 stainless steel and have fire wire low watt density technology for extended life Elements shall be rated at 14 KW.

Snap acting thermostat shall have a 200°F - 400°F (93°C - 204°C) temperature range. Manual or optional programmable computer controls shall be available. Large cool zone shall capture food and breading particles and keep them out of the frying area to improve food taste and prolong oil life. Fine mesh crumb screen shall be removable. Unit shall include removable drain pipe and clean out rod. Drain shall be a 1 1/4" (32) full port drain valve for quick draining.

## CLEARANCE

For use only on non-combustible floors. Legs or casters are required for non-combustible floors; or 2" (51) overhang is required when curb mounted. Provide 0" clearance from non-combustible surfaces and 8" (203) from combustible surfaces.

## ELECTRICAL REQUIREMENTS

Model	Total KW	Voltage	Phase	Amps
IFS-40E, IFS-40EU	14	208	3	38.91
	14	240	3	33.72
	14	480*	3	16.86

\* For export only, additional charge.

## OPTIONS AND ACCESSORIES

- Electronic Thermostat (per fryer) add suffix "T" to model number.
- Computer (per fryer) add suffix "C" to model number.
- Automatic Basket lifts w/ Computerized Controls.
- 1 Full Size Basket.
- Extra Twin Baskets, set of 2, specify model.
- Heat Lamp for model IF-DS.
- Stainless steel Joiner Strip.
- Casters 6" (152) , set of 4.
- Mechanical Timer.
- Side Drain Shelf, specify Right or Left.
- 20 1/2" (521) H Backguard, no shelf specify model.
- Stainless Steel Tank Cover, for all fryer models, please specify model.
- Stainless Steel side splash approx. 6" (152).
- Portable Filter Systems, 60 lbs. capacity.
- Portable Filter Systems, 90 lbs. capacity.

AIA File #:

Specification #:

## Imperial Commercial Cooking Equipment

1128 Sherborn Street | Corona, CA 92879 | 800.343.7790 | Ph: 951.281.1830 | Fx: 951.281.1879  
www.imperialrange.com | E-mail: imperialsales@imperialrange.com