

Counter Top Merchandisers

COLDT1

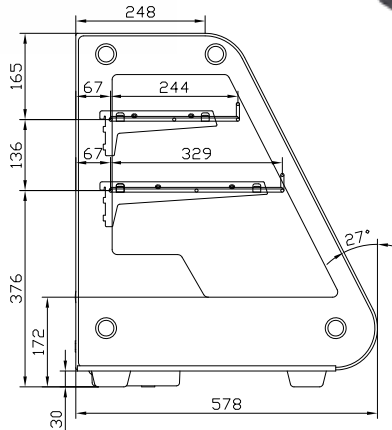

COLDT2



FEATURES

- Rear sliding doors, easily removable for cleaning
- 2 adjustable chrome plated shelves
- LED illumination with on/off switch

TECHNICAL SPECIFICATIONS

Controller:	Digital controller with temperature display on service side
Defrost:	Automatic
Refrigerant:	R600a
Climate Class:	4
Temperature Range:	+2°C ~ +12°C
Power Supply:	13amp

MODEL	FINISH	GROSS CAPACITY	EXT. DIMENSIONS (H x W x D mm)	POWER CONSUMPTION	DECIBELS	WEIGHT (kg)	RRP
COLDT1	Stainless steel construction	130L	677 x 697 x 578	180W	40-75dBA	63	
COLDT2		160L	677 x 875 x 578	180W	40-75dBA	67	

