

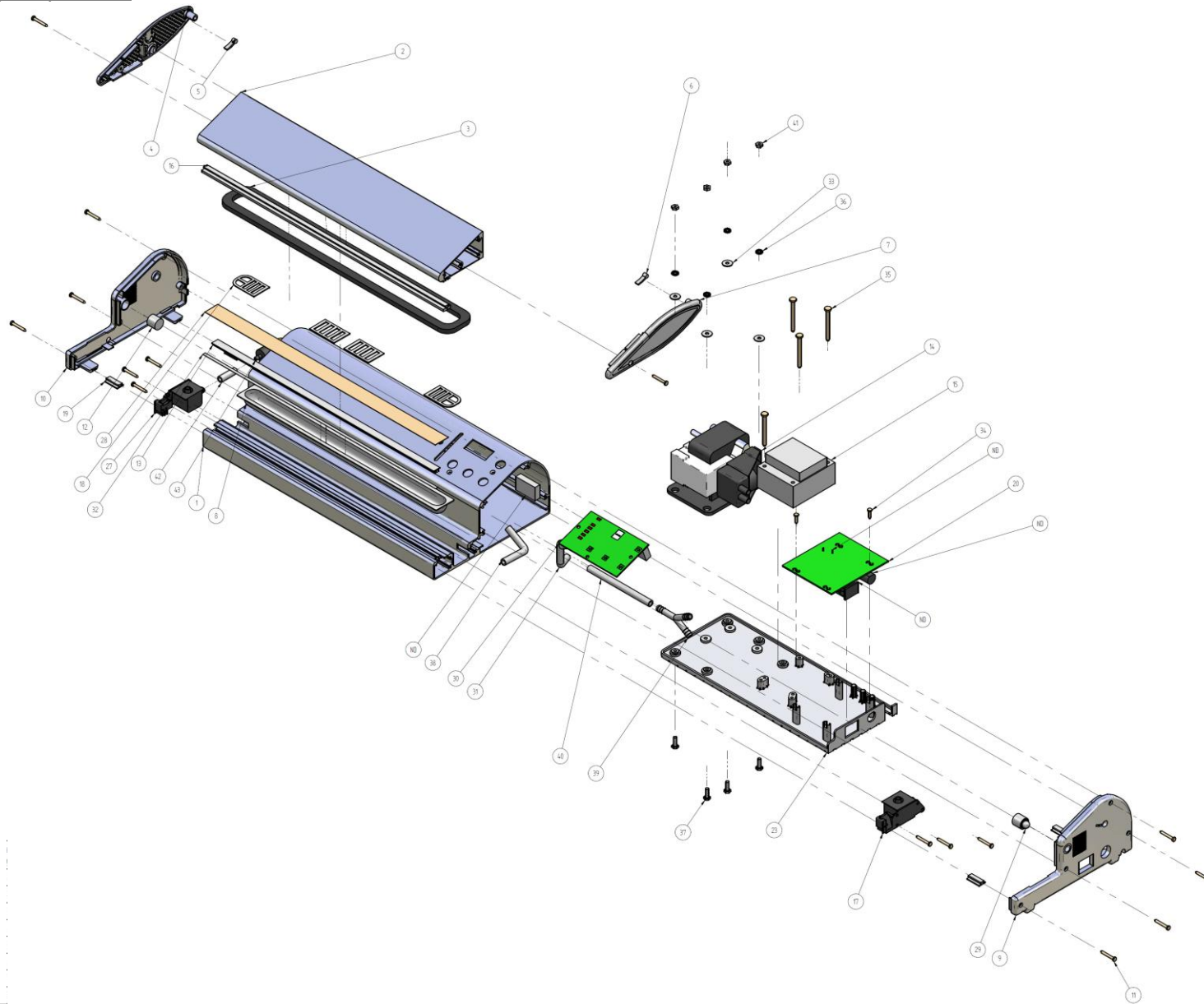









Exploded diagram and spare parts list

CC770



Machine	Explode	Code	Description
CC770 Buffalo Vacuum Pack Machine Type	1	AD637	Outer casing
CC770 Buffalo Vacuum Pack Machine Type	2	AD639	Sealing bar casing
CC770 Buffalo Vacuum Pack Machine Type	3	AD641	Sealing bar rubber gasket
CC770 Buffalo Vacuum Pack Machine Type	4	AD643	Sealing bar end cap lh
CC770 Buffalo Vacuum Pack Machine Type	5	AD645	Sealing bar ms operating lever lh
CC770 Buffalo Vacuum Pack Machine Type	6	AD646	Sealing bar ms operating lever rh
CC770 Buffalo Vacuum Pack Machine Type	7	AD644	Sealing bar end cap rh
CC770 Buffalo Vacuum Pack Machine Type	8	AD647	Liquid trap
CC770 Buffalo Vacuum Pack Machine Type	9	AD649	Outer casing end cap rh
CC770 Buffalo Vacuum Pack Machine Type	10	AD650	Outer casing end cap lh
CC770 Buffalo Vacuum Pack Machine Type	11		Screw
CC770 Buffalo Vacuum Pack Machine Type	12		Cap
CC770 Buffalo Vacuum Pack Machine Type	13	AD651	Heat sealing bar rubber
CC770 Buffalo Vacuum Pack Machine Type	14	AD653	Vacuum pump
CC770 Buffalo Vacuum Pack Machine Type	15	AD655	Voltage transformer
CC770 Buffalo Vacuum Pack Machine Type	16	AD657	Heat sealing bar rubber
CC770 Buffalo Vacuum Pack Machine Type	17	AD659	Suction tube cap
CC770 Buffalo Vacuum Pack Machine Type	18	AD660	Sealing bar end spacer
CC770 Buffalo Vacuum Pack Machine Type	19	AD661	Rubber foot
CC770 Buffalo Vacuum Pack Machine Type	20	AD662	Main operating PCB assembly
CC770 Buffalo Vacuum Pack Machine Type	23	AD663	Bracket
CC770 Buffalo Vacuum Pack Machine Type	27	AD664	Suction tube cap lh
CC770 Buffalo Vacuum Pack Machine Type	28	AD671	Teflon sealing tape
CC770 Buffalo Vacuum Pack Machine Type	29	AD669	Stainless steel ball
CC770 Buffalo Vacuum Pack Machine Type	30		Control panel PCB assembly
CC770 Buffalo Vacuum Pack Machine Type	31	AD665	Exhaust tube
CC770 Buffalo Vacuum Pack Machine Type	32	AD672	Resistance wire
CC770 Buffalo Vacuum Pack Machine Type	33		Washer
CC770 Buffalo Vacuum Pack Machine Type	34		Screw
CC770 Buffalo Vacuum Pack Machine Type	35		Screw
CC770 Buffalo Vacuum Pack Machine Type	36		Crimped washer
CC770 Buffalo Vacuum Pack Machine Type	37		Screw
CC770 Buffalo Vacuum Pack Machine Type	38	AD666	Tube drainage
CC770 Buffalo Vacuum Pack Machine Type	39		Y-shaped connector
CC770 Buffalo Vacuum Pack Machine Type	40	AD667	Suction tube
CC770 Buffalo Vacuum Pack Machine Type	41		Nut
CC770 Buffalo Vacuum Pack Machine Type	42	AD668	Linking tube
CC770 Buffalo Vacuum Pack Machine Type	43	AD673	Air vent