



## OE7505 - Phoenix Electric Free-standing Atmospheric Steamer - W 630 mm - 9.0 kW

The Phoenix Atmospheric Steamer has a generous capacity of 12 x 1/1GN, which is ideal for steaming vegetables, rice, fish and other foods.

- ✓ Perfect solution for volume production of healthy steamed food
- ✓ Ideal for steaming vegetables, puddings, rice, ham, fish and a range of other foods.
- ✓ Generous capacity 12x 1/1GN
- ✓ Six shelf positions and removable shelf supports for maximum versatility
- ✓ 304 grade stainless steel oven interior for long service life
- ✓ Thermostatic control and boil dry protection for trouble free operation

### Specifications

#### Summary

|                             |                                   |
|-----------------------------|-----------------------------------|
| <b>Range Name</b>           | Phoenix                           |
| <b>Power Type</b>           | Electric                          |
| <b>Unit Type</b>            | Free-standing                     |
| <b>Available in UK Only</b> | No                                |
| <b>UK Warranty</b>          | 2 Years Parts and Labour Warranty |
| <b>Export Warranty</b>      | Contact your local dealer         |
| <b>GTIN Code</b>            | 5056105109785                     |

#### Power and Performance

|                            |            |
|----------------------------|------------|
| <b>Gastronorm Capacity</b> | 6 x GN1/1  |
| <b>Total Power kW</b>      | 9.0        |
| <b>IP Rating</b>           | IP24       |
| <b>Temperature Control</b> | Mechanical |
| <b>Oven Rating kW</b>      | 9.0        |

#### Key Specifications

|                                   |   |
|-----------------------------------|---|
| <b>Number of Shelves included</b> | 6 |
| <b>Number of Shelf Positions</b>  | 6 |

#### Weights and Dimensions

|                                  |      |
|----------------------------------|------|
| <b>Unit Height (External) mm</b> | 1620 |
| <b>Unit Width (External) mm</b>  | 630  |
| <b>Unit Depth (External) mm</b>  | 820  |
| <b>Height (Internal) mm</b>      | 680  |
| <b>Width (Internal) mm</b>       | 520  |
| <b>Depth (Internal) mm</b>       | 500  |
| <b>Shelf Dimensions Width mm</b> | 510  |
| <b>Shelf Dimensions Depth mm</b> | 500  |
| <b>Net Weight Kg</b>             | 110  |

#### Supply Connections

|                                       |                             |
|---------------------------------------|-----------------------------|
| <b>Requires Installation</b>          | Yes                         |
| <b>Requires Electrical Supply</b>     | Yes                         |
| <b>UK 3 Pin Plug</b>                  | No                          |
| <b>Requires Hardwiring</b>            | Yes                         |
| <b>Electrical Supply Rating Watts</b> | 9,000                       |
| <b>Single Phase Amps</b>              | 39.1                        |
| <b>Single Phase Voltage</b>           | 230                         |
| <b>Three Phase Amps</b>               | L1=13.0 ; L2=13.0 ; L3=13.0 |
| <b>Three Phase Voltage</b>            | 400                         |
| <b>Water Connection BSPT</b>          | 15 mm                       |
| <b>Water Connection Pressure Bar</b>  | 0.2 - 10.0                  |

#### Shipping

|                         |     |
|-------------------------|-----|
| <b>Packed Weight Kg</b> | 122 |
| <b>Packed Height cm</b> | 184 |
| <b>Packed Width cm</b>  | 100 |
| <b>Packed Depth cm</b>  | 80  |

### Technical Picture

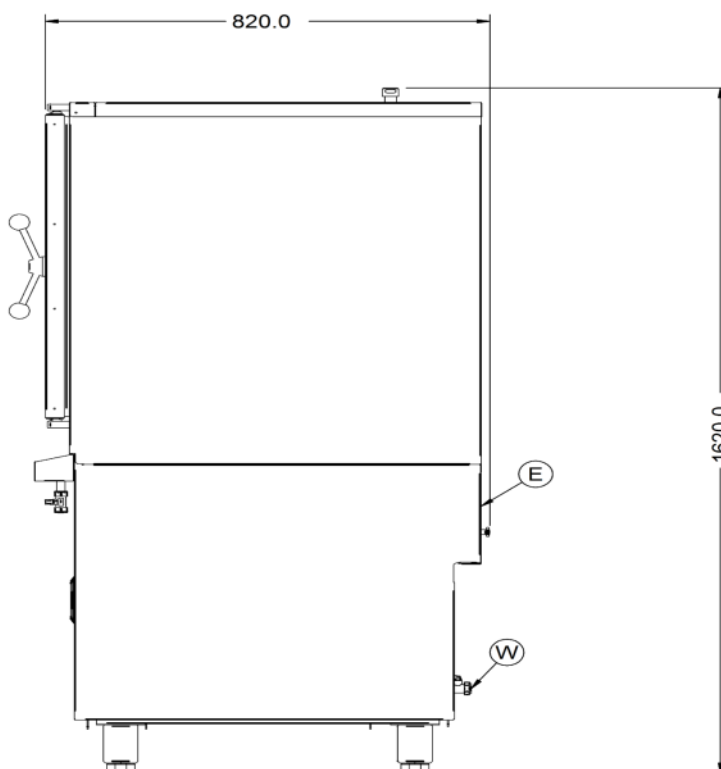
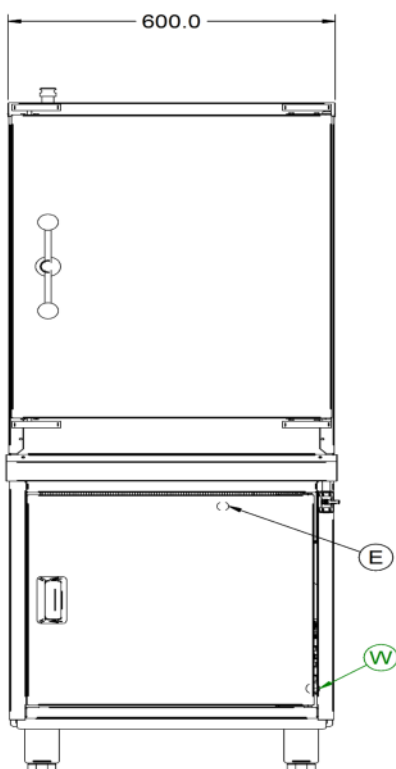
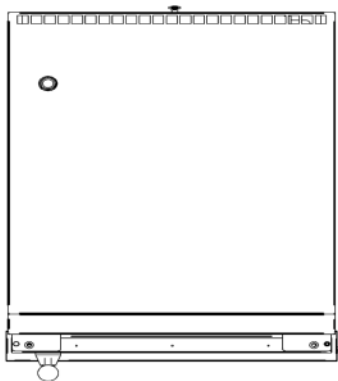

**Lincat Limited**

Whisby Road,  
Lincoln, LN6 3QZ,  
United Kingdom

**Company No:** 2175448

A member company of



**Customer Care**

**Tel:** +44 1522 875500  
**Email:** care@lincat.co.uk

**Export Customers**

**Tel:** +44 1522 503250  
**Email:** export@lincat.co.uk

**Opening Hours**

**Monday – Friday:**  
8.30am – 5pm