



# VEGETABLE PREPARATION MACHINE CA-31

Vegetable preparation machine. Production up to 450 Kg.



DYNAMIC PREPARATION  
COMMERCIAL VEGETABLE PREPARATION MACHINES

## SALES DESCRIPTION

Single-speed motor block + regular hopper.

### A perfect cut

- ✓ High precision adjustments to obtain a uniform and excellent-quality cut.
- ✓ It can be fitted with a wide range of discs and grids of the highest cutting quality. Combining these accessories together to obtain more than 70 different types of cuts and grating grades.

### Built to last

- ✓ Made from stainless steel and food-grade materials of the highest quality: stainless steel motor block and food-grade aluminium head.
- ✓ High power asynchronous motor.

### Maximum comfort for the user

- ✓ Ergonomic design: product sliced in one single movement.
- ✓ Lateral product output: requires less space on the worktop and guides the product, avoiding splashes.
- ✓ The electronic command panel is very intuitive.

### Maintenance, safety, hygiene

- ✓ Lever and lid easily removable for cleaning purposes.
- ✓ Combination of safety systems: head, cover, power switch.
- ✓ Appliance certified by NSF International (regulations on hygiene, cleaning and materials suitable for contact with foods).
- ✓ 100% tested.

## INCLUDES

- ✓ Single-speed motor block.
- ✓ Regular hopper.

## OPTIONAL

- Tube head for long products.
- Discs and grids.
- Support-trolley.
- Grid cleaning kit.

## ACCESSORIES

- FCC curved slicing discs
- FCO rippled slicing discs
- FFC chipping grids
- FMC dicing grids
- FCE julienne discs
- FR shredding & grating discs
- Long vegetable attachment
- Disc and grid holder
- Stand-trolley
- Grid cleaning kit
- FC-D slicing discs
- SH shredding & grating discs

## SPECIFICATIONS

Hourly production: 150 Kg - 450 Kg

Inlet opening: 136 cm<sup>2</sup>

Disc diameter: 205 mm

Motor speed: 365 rpm

### Loading

Single Phase: 550 W

Three phase: 550 W

Electrical connection: --

**Noise level (1m.):** <70 dB(A)

**Background noise:** 32 dB(A)

### External dimensions (WxDxH)

Width: 389 mm

Depth: 405 mm

Height: 544 mm

**Net weight:** 21 Kg

### Crated dimensions

435 x 430 x 600 mm

Volume Packed: 0.11 m<sup>3</sup>

## AVAILABLE MODELS

1050701 Vegetable preparation machine CA-31 230-400/50/3N

1050700 Vegetable preparation machine CA-31 230/50/1

1050702 Vegetable preparation machine CA-31 120/60/1

1050705 Vegetable preparation machine CA-31 220/60/1

1050707 Vegetable preparation machine CA-31 220-380/60/3N

1050712 Vegetable preparation machine CA-31 230/50/1

\* Ask for special versions availability





# VEGETABLE PREPARATION MACHINE CA-31

Vegetable preparation machine. Production up to 450 Kg.



DYNAMIC PREPARATION  
COMMERCIAL VEGETABLE PREPARATION MACHINES

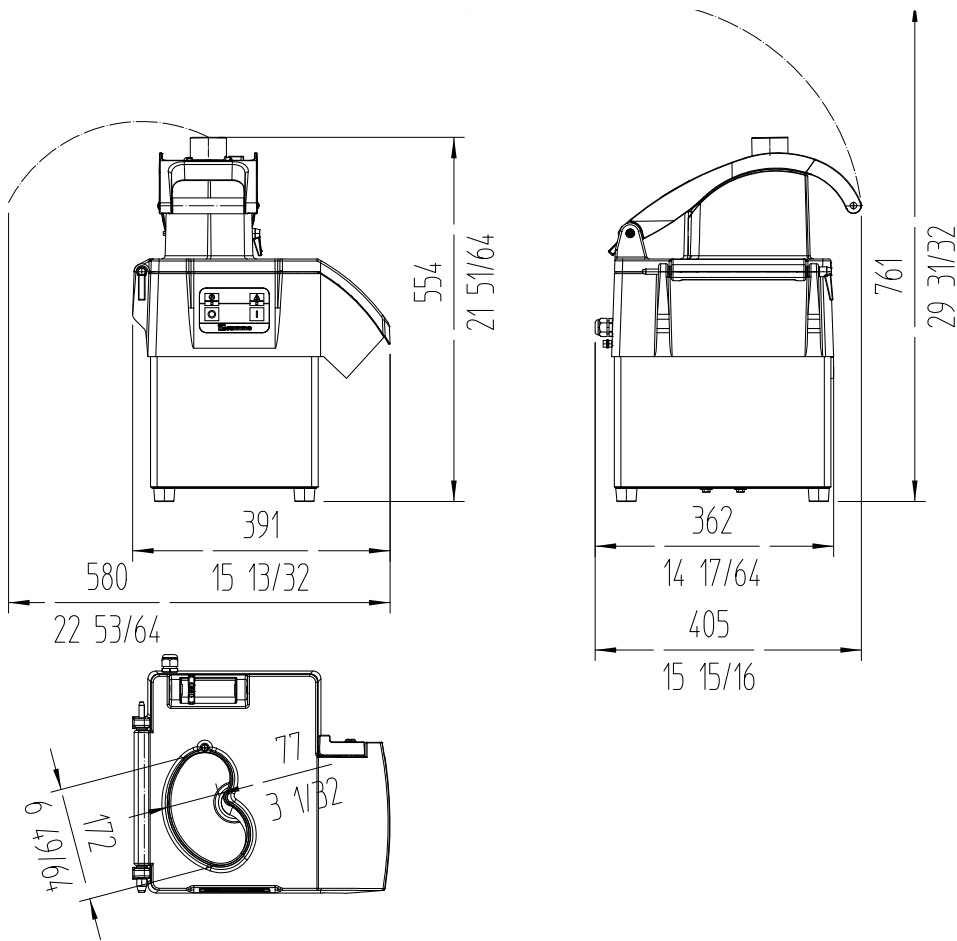

[www.sammic.co.uk](http://www.sammic.co.uk)

Food Service Equipment Manufacturer

Unit 2, Trevanth Road  
Troon Industrial Park  
LE4 9LS - Leicester

[uksales@sammic.com](mailto:uksales@sammic.com)  
Tel.: +44 0116 246 1900



Project

Date

Item

Qty

Approved

product sheet  
updated 07/06/2023