



PROJECT:	MODEL:	QUANTITY:	ITEM NO:
----------	--------	-----------	----------

# COOK & HOLD OVEN

**For 12"x 20" Pans, 18"x 13" Trays and GN 1/1 Containers**

**COOK AND HOLD "LCHR" SERIES**

**Big performance in a small space!  
Perfect Cook and Hold oven for countertop or built-in applications**



- 1 Ideal for countertop use or built in applications – sized perfect for smaller volume operations or volume feeders with constant replenishment, restaurants and food court operations. Stackable modular design
- 2 Intuitive, easy to use and kitchen friendly controls allow for 8 programmable recipes for consistent results. Provided with an internal product probe, allowing the options to cook and hold by probe or by time without constant monitoring
- 3 Save space and money - FWE's Cook and Hold Ovens are designed to not require a hood. The modular design allows you to use it where you need it, when you need it (local codes prevail)
- 4 Cook, re-heat and hold a large variety of foods in the same cabinet. These versatile ovens reduce drying, shrinkage and flavor loss. When not being used for cooking, these ovens can be used for holding prepared foods
- 5 Standard with a 15 amp cord and plug, the cabinet can be operated with no worries about power restrictions. These ovens typically require up to 50% less energy than a conventional oven



**\*Two year limited warranty**

LCHR-1220-4



Stackable Design



Control Panel



Designed To Not Require A Hood



Reduce Shrinkage



# SPECIFICATIONS: COOK & HOLD OVEN

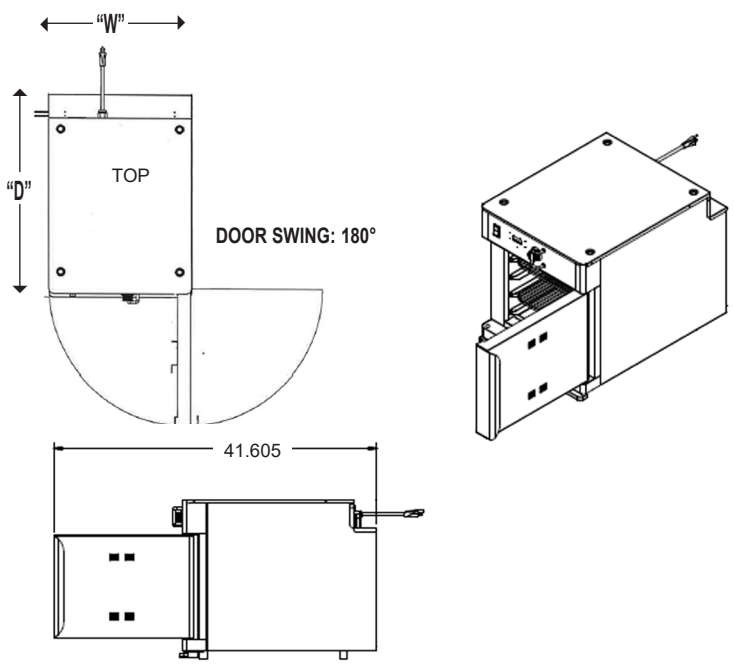
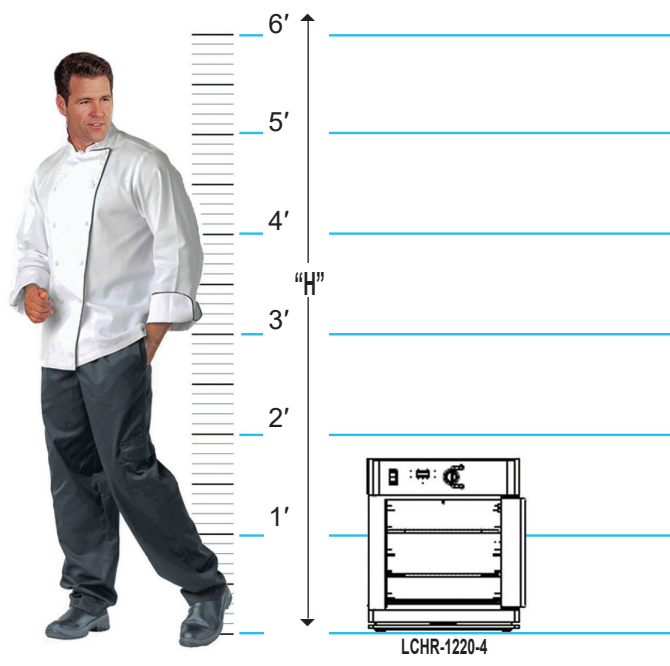

CAPACITIES OF 12" x 20" OR GN 1/1 PANS [A]											
MODEL NUMBER	2.625" FIXED SPACINGS			66.7MM FIXED SPACINGS			OVERALL EXTERIOR DIMENSIONS IN. (mm)			CLASS 100 NUMBER OF DOORS	SHIP WT. LBS. (KG)
	DEPTH 12" x 20" PANS			DEPTH GN 1/1 PANS			HIGH "H"	DEEP "D"	WIDE "W"		
	2.5"	4"	6"	65MM	100MM	150MM					
LCHR-1220-4	4	2	1	4	2	1	20.5" (521)	26.25" (667)	18" (457)	1	125 (57)

[A] Combinations of deep and shallow pans may be used with varying capacities. Also accommodates one (1) 18" x 13" x 1.5" tray per set of slides.

ELECTRICAL DATA	
LCHR-1220-4	
VOLTS	120
WATTS	950
AMPS	7.9
HERTZ	60
PHASE	Single
PLUG USA	5-15P
PLUG CANADA	5-15P

**CONSTRUCTION.** Heliarc welded, single unit construction of stainless steel; 20 gauge polished exterior, 18 gauge stainless steel interior with easy-to-clean coved corners.  
**INSULATION.** Insulated throughout; top, back, bottom, sides, doors using high density ceramic and fiberglass insulation.  
**DOOR AND LATCHES.** Flush mounted, field reversible, stainless steel insulated doors. High temperature gasket sealed; gasket shall be door mounted. Door shall be vented and have heavy duty pin style hinges.  
**LEGS.** Oven includes one (1) set of 1" non-skid rubber feet.

**PAN SLIDES.** Stainless steel racks shall be one piece die stamped channel-type pan slides at 2.625" (66.7mm) spacings to accommodate either deep or shallow 12" x 20" or GN 1/1 pans (at varying capacities - see chart). Two (2) stainless steel shelves provided.  
**DRIP PAN.** Stainless steel drip pan rests on cabinet floor and is removable. Exterior drip tray is also removable.  
**HEATING SYSTEM.** Built-in heat system with uniform low watt density radiant heat source that creates highly accurate temperature tolerances throughout the cooking and holding functions. Minimal air movement offers uniform and consistent cooking, low shrinkage, and higher food yields of bulk or portion items, higher food moisture content, and significantly longer food holding life. Heat system provides fast heat up, recovery and accurate temperature set points.

**CONTROL PANEL.** Easy to operate, automatic controls include intuitive easy to use / easy to read kitchen friendly controls allows "set-and-forget" consistent results. Cooking by time or by internal product temperature with probe (included) when cook cycle is complete, controller automatically switches from cook cycle to hold cycle. Unit has preset function to store and quickly retrieve up to 8 recipes. Adjustable COOK control up to 250°F (121°C) and adjustable HOLDING control up to 200°F (93°C). Shall include ON/OFF switch. Actual cabinet temperature reading is LED displayed during each cycle and probe temp display.

**VENTING.** Venting may be required. Local codes may restrict a maximum oven temperature lower than 250°F (121°C). Factory or field adjustment ready. Consult factory if lower temperature is required for local codes.  
**ELECTRICAL CHARACTERISTICS.** 3 wire grounded 6 foot extension power cord and plug, rear mounted for safety. See electrical data chart above for amperage and receptacle configuration.  
**INSTALLATION.** Unit should not be installed in an area where adverse environmental conditions are present.

- OPTIONAL ACCESSORIES**
- DOORS**
    - Left hand door hinging
  - SPACINGS**
    - Custom pan slide spacings
    - Extra stainless steel shelves
  - HANDLES**
    - Side mounted lift handles
    - Recessed antimicrobial handles

FWE products may be covered under one or more of the following U.S. patents: 288,299;238,300;3,952,609;4,192,991. All rights reserved. All specifications subject to change without notice. Errors subject to correction. © 17 Food Warming Equipment Company, Inc. R.17.01



**FOOD WARMING EQUIPMENT COMPANY, INC.**  
 5599 HWY. 31 W. Portland, TN 37148  
 815.459.7500 | Fax: 815.459.7989 | sales@fwe.com

**800-222-4393**  
**www.FWE.com**

