

# Eskimo Ice Cream Display

**ESKIMO7**

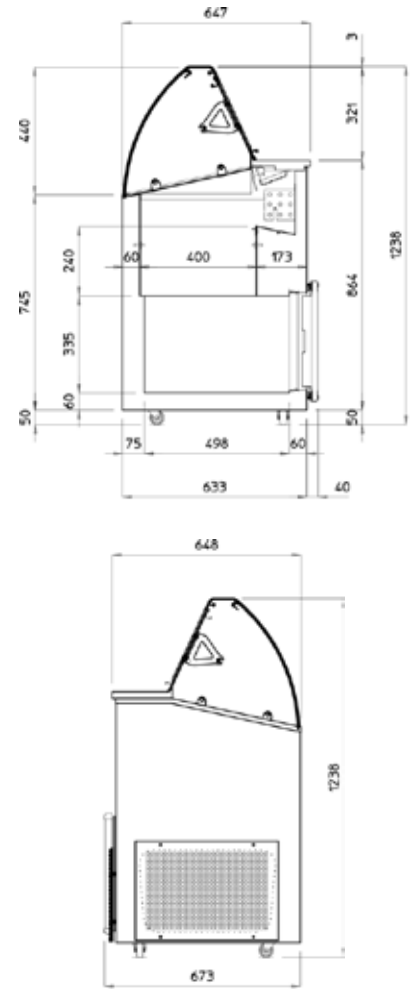

## FEATURES

- White pre-painted steel exterior & interior
- Static packed evaporation system (with defrosting resistance) + evaporator coil foamed on the walls
- Insulating upper curved glazed glass
- Accepts 5 litre Napoli containers (not supplied)
- Separate storage accessible via a door

## TECHNICAL SPECIFICATIONS

Controller:	Digital controller with temperature display
Cooling:	Static
Defrost:	Automatic
Refrigerant:	R507
Climate Class	3
Temperature Range:	-15°C ~ -20°C
Power Supply:	13amp

MODEL	DISPLAY CAPACITY*	STORAGE CAPACITY*	EXTERNAL DIMENSIONS (H x W x D mm)	POWER CONSUMPTION	WEIGHT (kg)	RRP
ESKIMO6	6	8	1238 x 1200 x 673	420W	115	
ESKIMO7	7	12	1238 x 1350 x 673	480W	119	

\* Capacity for 5L Napoli containers



## NOTES

Glass structure is fully assembled prior to despatch.

