



MODEL CTB/CTBR

Half-size Electric Convection Oven



Project _____

Item No. _____

Quantity _____

Standard depth baking compartment - accepts 13" x 18" standard half-size baking pans in front-to-back-position. CTBR model follows same specifications as CTB, only with door opening on the right side and controls on left side. All data is shown per oven section, unless otherwise indicated.

EXTERIOR CONSTRUCTION

- Full angle-iron frame
- Stainless steel front, top, sides and back
- Dual pane thermal glass window encased in stainless steel door frame
- Single chrome plated door handle
- Tilt-down modular front control panel
- Solid mineral fiber insulation at top, back, sides and bottom

INTERIOR CONSTRUCTION

- Double-sided porcelainized baking compartment liner (14 gauge)
- Five chrome-plated racks, nine rack positions with a minimum of 1-5/8" (41mm) spacing

OPERATION

- Two tubular heaters (5kW)
- Solid state thermostat with temperature control range of 200°F (93°C) to 500°F (260°C)
- Two speed fan motor
- 1/4 horsepower blower motor with automatic thermal overload protection
- One control area cooling fan

STANDARD FEATURES

- Solid state manual with separate dials to control thermostat and time**
- Two year parts and labor oven warranty*
- Five year oven door warranty*

* For all international markets, contact your local distributor.

** For control panels other than standard consult your local international distributor for CE approvals.

OPTIONS AND ACCESSORIES

(AT ADDITIONAL CHARGE)

- **Control options:**
 - Pulse Plus®
 - Cook & Hold
 - Solid state digital with cook and hold, and Pulse Plus® with digital display
 - Blodgett IQ®
- **Legs/casters:**
 - 4" (102mm) black legs
 - 6" (152mm) casters
- **Stands:**
 - 5-3/4" (146mm) stainless steel stand
 - 7" (178mm) stainless steel stand (not for use with casters)
 - 16" (406mm) stainless steel stand
 - 19" (438mm) stainless steel stand with shelf
 - 24" (610mm) stainless steel stand with shelf
 - 33" (838mm) stainless steel stand with shelf
- Vent riser: stainless steel
- Cord set with receptacle
- 7.5 Kw elements
- Extra oven racks
- Oven Liner: Stainless steel

OPTIONS AND ACCESSORIES

(AT NO CHARGE)

- Door Design: Solid stainless steel
- Right hand hinged door



BLODGETT OVEN COMPANY

www.maytagfoodservice.com

50 Lakeside Avenue, Burlington, VT 05402

Toll Free: (800) 331-5842 • Phone: (802) 860-3700 • Fax: (802) 864-0183



FOODSERVICE DIVISION

MODEL CTB/CTBR

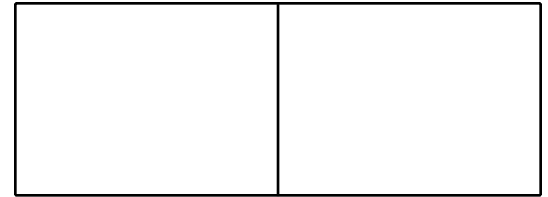

APPROVAL/STAMP

TOP VIEW

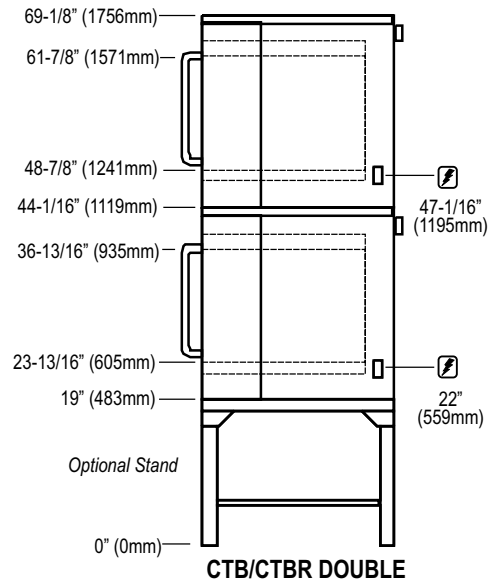
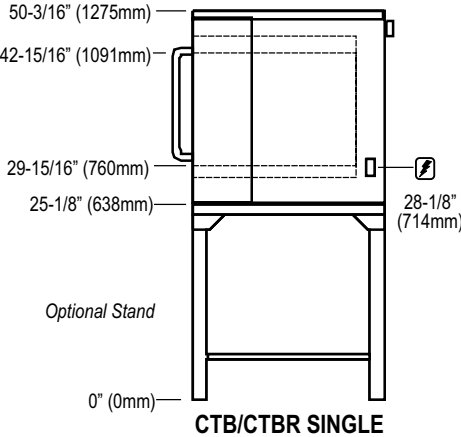
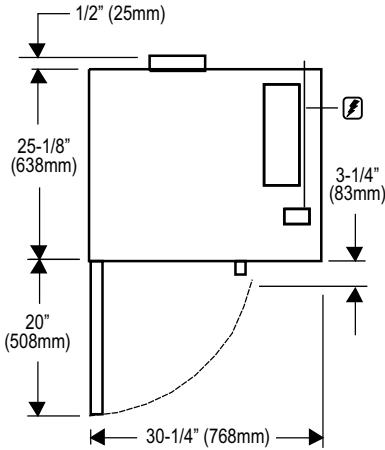

SHORT FORM SPECIFICATIONS

Provide Blodgett half-size convection oven model CTB/CTBR (single, double) compartment. Each compartment shall have (porcelainized/stainless) steel liner and shall accept five 13" x 18", standard half-size bake pans. Doors shall be (dual pane thermal glass/window/solid stainless steel door) with single chrome plated door handle. Stainless steel front, top, sides and legs. Unit shall be electrically heated with two or three tubular heaters dependent on wattage (5 or 7.5 kW) selection. Air in baking chamber distributed by blower wheel powered by two-speed, 1/4 horsepower motor with thermal overload protection. Each chamber shall be fitted with five chrome plated removable racks, and have nine rack positions. Control panel shall be recessed with Cook/Cool Down mode selector, solid state (manual/digital) infinite thermostat (200°-500°F), and 60-minute timer. Provide options and accessories as indicated.

DIMENSIONS:

Floor space 30-1/4" (768mm) W x 25-1/8" (638mm) D
Product clearance 0" from combustible and non-combustible construction.
Interior 15-1/4" (387mm) W x 20" (508mm) H x 21" (533mm) D

MAXIMUM INPUT:

CTB/CTBR single 5.6KW (8.0 KW increase option available)
CTB/CTBR double 11.2KW (16 KW increase option available)

MINIMUM ENTRY CLEARANCE:

Uncrated 25-1/16" (636mm)
Crated 30-1/4" (775mm)

SHIPPING INFORMATION:

Approx. Weight: **Crated** **Uncrated**
Single 260 lbs. (118 kg) 225 lbs. (102kg)
Double 520 lbs. (236 kg) 450 lbs (204 kg)

Crate size:

30-1/2" (775mm) x 35" (889mm) x 33" (838mm)

POWER SUPPLY:

Standard:

208 VAC, 60 Hz., 1 phase, 5.6KW, 27/0/27 Amperes
208 VAC, 60 Hz., 3 phase, 5.6KW, 24/12/15 Amperes
220-240 VAC, 60 Hz., 1 phase, 5.6KW, 24/0/24 Amperes
220-240 VAC, 60 Hz., 3 phase, 5.6KW, 21/11/14 Amperes

Increased Output:

208 VAC, 60 Hz., 1 phase, 8KW, 35/0/35 Amperes
208 VAC, 60 Hz., 3 phase, 8KW, 22/20/21 Amperes
220-240 VAC, 60 Hz., 1 phase, 8KW, 32/0/32 Amperes
220-240 VAC, 60 Hz., 3 phase, 8KW, 20/18/19 Amperes

Export:

220-240 VAC, 50 Hz., 1 phase, 5.6KW, 24/0/24 Amperes
220-240 VAC, 50 Hz., 1 phase, 8KW, 35/0/35 Amperes
220/380 VAC, 50 Hz., 3 WYE phase, 5.6KW, 10/8/8 Amperes
220/380 VAC, 50 Hz., 3 WYE phase, 8KW, 14/12/12 Amperes
240/415 VAC, 50 Hz., 3 WYE phase, 5.6KW, 10/7/7 Amperes
240/415 VAC, 50 Hz., 3 WYE phase, 8KW, 13/11/11 Amperes
230/400 VAC, 50 Hz., 3 WYE phase, 5.6KW, 9/8/8 Amperes
230/400 VAC, 50 Hz., 3 WYE phase, 8KW, 13/11/11 Amperes

NOTE: The company reserves the right to make substitutions of components without prior notice

1/4 H.P., 2 speed motor, 1140 and 1725 RPM (60Hz.)

1/4 H.P., 2 speed motor, 1425 and 950 (50Hz.)

This oven contains a mercury relay. DO NOT put mercury relay in trash. Relay must be recycled or disposed of as hazardous waste.

BLODGETT OVEN COMPANY

www.maytagfoodservice.com

50 Lakeside Avenue, Burlington, VT 05402

Toll Free: (800) 331-5842 • Phone: (802) 860-3700 • Fax: (802) 864-0183