



TRUE EUROPE

UK OFFICE: Field's End Road, Goldthorpe, Nr. Rotherham, South Yorkshire S63 9EU, UK  
 Tel +44 01709 888 080 • Fax +44 01709 880 838 • Free Phone 0 800 783 2049  
 Free Phone to U.S. 0 800 894 928 • EU OFFICE: Hauptstr. 269 • 79650 Schopfheim • Germany  
 Tel +49 07622 6883 0 • Fax +49 07622 6883 499 • www.truefmfg.com



8/16

Model:  
**T-49F-HC**

**T-Series:**  
 Reach-In Solid Swing Door Freezer with Hydrocarbon Refrigerant



### T-49F-HC

- ▶ True's solid door reach-in's are designed with enduring quality that protects your long term investment.
- ▶ Designed using the highest quality materials and components to provide the user with colder product temperatures, lower utility costs, exceptional food safety and the best value in today's food service marketplace.
- ▶ Factory engineered, self-contained, capillary tube system using environmentally friendly R290 hydro carbon refrigerant that has zero (0) ozone depletion potential (ODP), & three (3) global warming potential (GWP).
- ▶ High capacity, factory balanced refrigeration system that maintains -10°F (-23.3°C) temperatures. Ideal for both frozen foods and ice cream.
- ▶ Stainless steel solid doors and front. The very finest stainless with higher tensile strength for fewer dents and scratches.
- ▶ Adjustable, heavy duty PVC coated shelves.
- ▶ Positive seal self-closing doors. Lifetime guaranteed door hinges and torsion type closure system.
- ▶ Automatic defrost system time-initiated, temperature-terminated. Saves energy consumption and provides shortest possible defrost cycle.

**Bottom mounted units feature:**

- ▶ "No stoop" lower shelf.
- ▶ Storage on top of cabinet.
- ▶ Compressor performs in coolest, most grease free area of kitchen.
- ▶ Easily accessible condenser coil for cleaning.

ENERGIA - ENERGIJA - ENERGIJA  
 ENERGIJA - ENERGY - ENERGIJA  
 ENERGIJA - ENERGY - ENERGIJA

4478 kWh/annum

914 L

4 30°C-55%

2015/1094

### PLAN VIEW

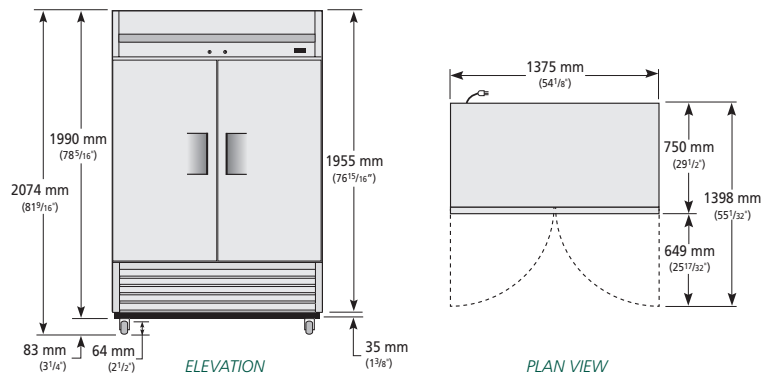

### ROUGH-IN DATA

Specifications subject to change without notice.  
 Chart dimensions rounded up to the next whole millimeter (inches rounded up to the next 1/8").

Model	Model Type	Doors	Shelves	Cabinet Dimensions (mm)			Net Volume (litres)	EEC	EEI	24 hr/ Energy Consumption (kWh)	Annual Energy Consumption (kWh)	Crated Weight (kg)
				L	D	H						
T-49F-HC	Vertical Frozen	2	8	1375	750	2074	914	D	75	12.268	4478	200