



Shown with optional 6" extension tray



## Principle

Middleby Marshall PS Series conveyor ovens bake both faster and at a lower temperature than other ovens. Vertical columns of hot air move heat aerodynamically instead of using high temperatures. The streams of hot air remove the boundary layers of cool heavy air which tend to insulate the product. All Middleby ovens are designed to cook a multitude of products including pizza, seafood, sandwiches, bagels, ethnic foods and more.

## General Information

The PS520 conveyor oven is ideally suited for Kiosk and express-style locations where smaller ovens are required.

## Standard Features

- Patented EMS Energy Management System\* reduces gas consumption and increases cooking efficiency
- 20" (508mm) long cooking chamber with 18" (457.2mm) belt
- 42" (1066.8mm) long, 37-1/2" (953mm) deep, and 21-3/4" (552.4mm) high overall dimensions
- Furnished with 4" (101.6mm) legs
- Stackable up to three high.
- Microprocessor-controlled bake time/conveyor speed
- Stainless steel front, sides, top and interior
- Reversible conveyor direction
- 12" (304.8mm) Extension Tray

## Optional Features

- 6" (152.4mm) Extension Tray
- Stand with casters
- Extended warranty available

## Conserves Energy

Unit incorporates a patented Energy Management System - EMS. Middleby ovens provide very efficient heat transfer to product. Energy is conserved as air is recycled from heater to product, with minimum loss. Oven is cool to the touch.

## Cleanability

PS520 Ovens are designed for easy cleaning. Removable parts include: crumb pans, end panels, air fingers, exit tray, and a removable conveyor belt assembly.

## Easily Services

Control compartment is designed for quick and easy access.

## Warranty

All PS520 models have a one year parts and labor warranty.

## Ventilation

Use of a ventilation hood is required.

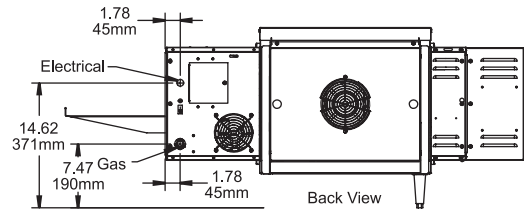
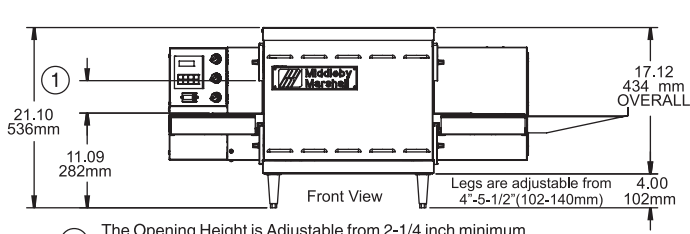

① The Opening Height is Adjustable from 2-1/4 inch minimum to 3-3/4 inch maximum in 1/2 inch increments.

**PS520-1**

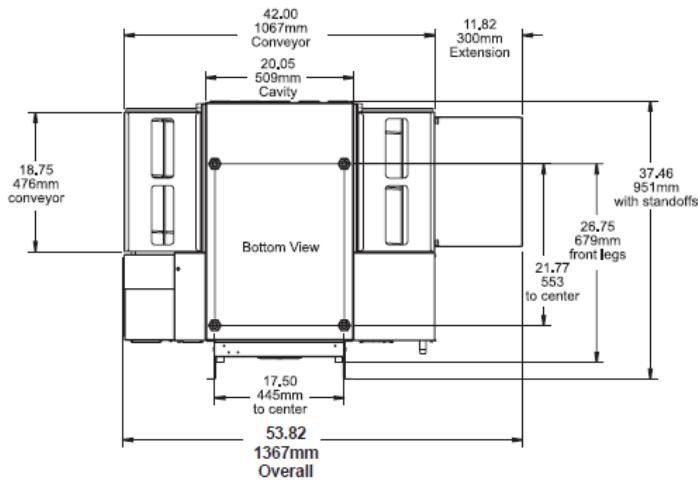

① The Opening Height is Adjustable from 2-1/4 inch minimum to 3-3/4 inch maximum in 1/2 inch increments.

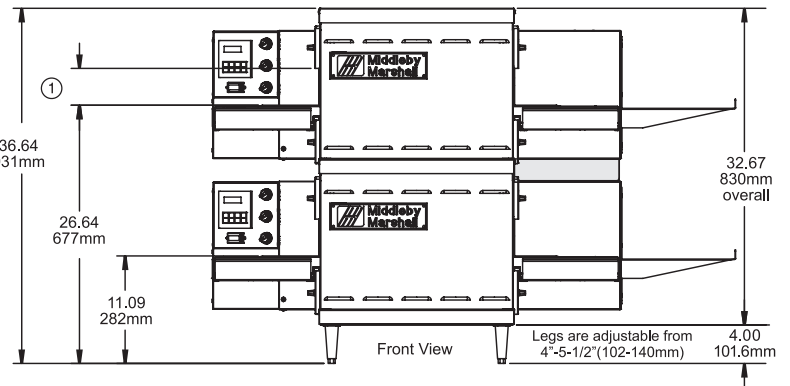

**PS520-2**

② P/N 59927 is shown in its correct installed position & must be installed in the field on all double & triple stack ovens.

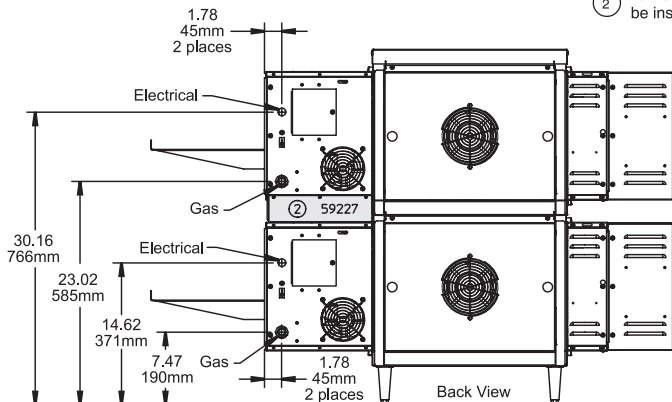

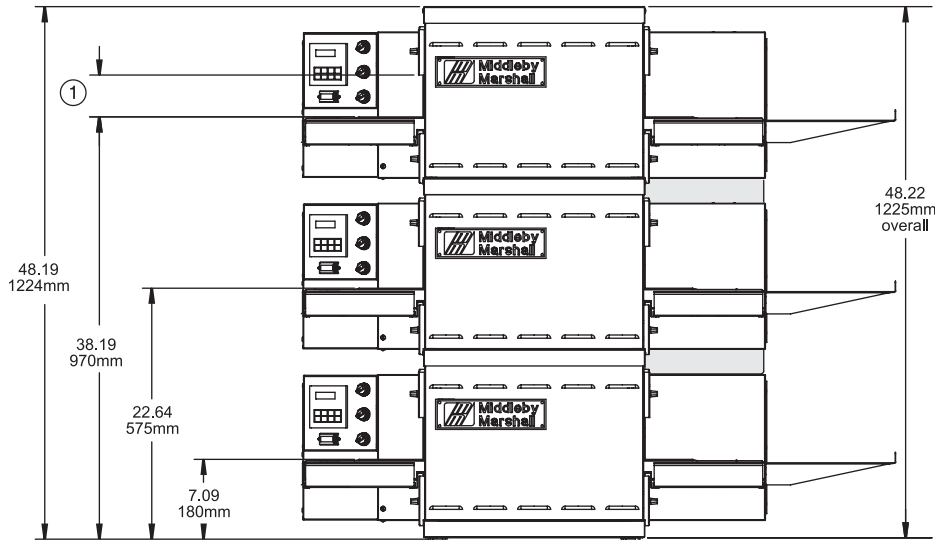

Front View

- ① The Opening Height is Adjustable from 2-1/4 inch minimum to 3-3/4 inch maximum in 1/2 inch increments.
- ② P/N 59927 is shown in its correct installed position & must be installed in the field on all double & triple stack ovens.

**PS520-3**

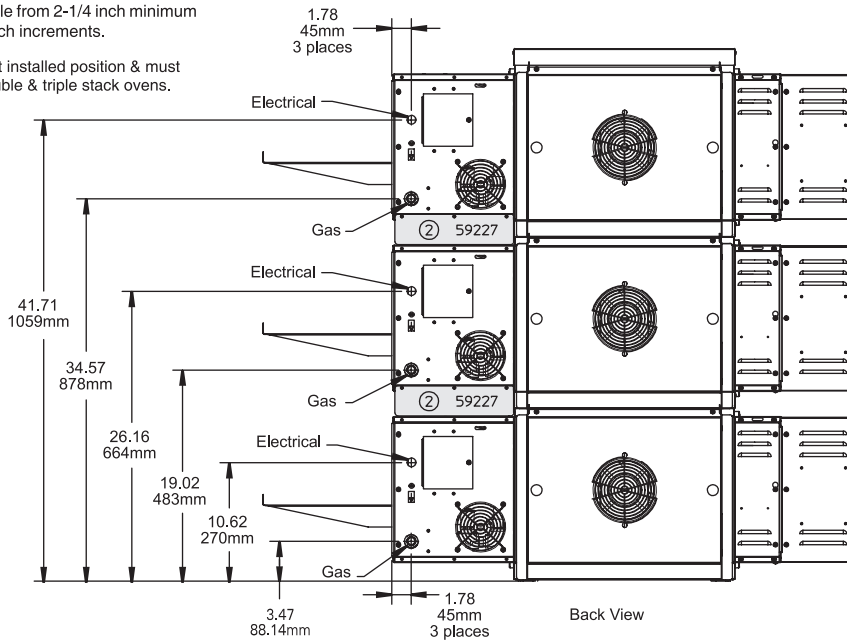

Back View

**Optional stand available for all PS520 Series Models**

Stand for *Single and Double Oven Only*

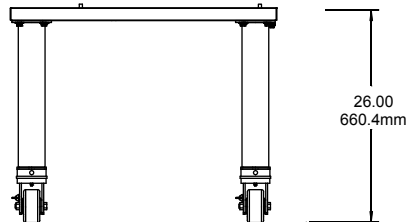

Stand for *Triple Oven Only*

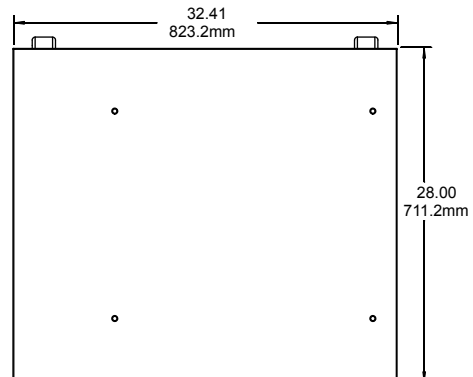
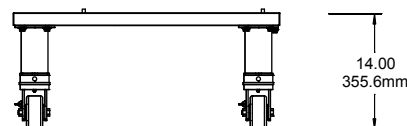

**RECOMMENDED MINIMUM CLEARANCES**

Rear of Oven to Wall	Control end of conveyor to wall	Non-control end of conveyor to wall
0"	0"	0"

**GENERAL SPECIFICATIONS**

	Heating Zone	Baking Area	Belt Length	Belt Width	Overall Length (12" exit tray installed)	Height without 4" legs	Depth	Maximum Operating Temp	Bake Time Range	Ship Wt	Ship Cube
PS520-1	20" 508mm	2.5 sq ft 0.23 sq m	42" 1066 mm	18" 457mm	53.82" 1367mm	17.12" 434mm	37.46" 951mm	550°F 288°C	1-10 min	325 lbs 147.42kg	22.1 ft3 0.62m3
PS520-2	40" 1016mm	5.0 sq ft 0.46 sq m	42" 1066 mm	18" 457mm	53.82" 1367mm	32.67" 830mm	37.46" 951mm	550°F 288°C	1-10 min	650 lbs 294.48 kg	44.2 ft3 1.24m3
PS520-3	60" 1524mm	7.5 sq ft 0.69 sq m	42" 1066 mm	18" 457mm	53.82" 1367mm	48.19" 1224mm	37.46" 951mm	550°F 288°C	1-10 min	975 lbs 442.25 kg	66.3 1.86m3

**ELECTRICAL SPECIFICATIONS**

Version	Voltage	Phase	Freq	Current Draw	Supply	Breakers
Domestic and std. export	208/240v	1	50/60 hz	1.5 Amp	2 pole, 3 wire	As per local codes

\* The current draw rating shown above are maximum values for normal operation, amperage draw will be less than the listed value.

Each oven includes a 6 ft cord with NEMA# L6-20P plug. Customer to provide NEMA# L6-20R receptical.

**GAS SUPPLY SPECIFICATIONS**

Version	Gas Type	Supply (inlet) Pressure	Regulated Pressure	Rated Heat Input
Domestic & std export	Natural Gas	6-12" W.C. (14.9-29.9mbar) *	3.5" W.C. (8.72mbar)	40,000 BTU
Domestic & std export	Propane Gas	11-14"W.C. (27.4-34.9mbar) *	10" W.C. ( 24.9mbar)	40,000 BTU

\* The required gas supply pressures of other locations are dependent on the local gas type and on all applicable local codes.

**Minimum Gas Pipe Sizes:**

- \* Natural Gas - 1 1/2" (31.8 mm) main supply line. One 3/4" (19mm) NPT branch per oven cavity with individual full-flow shutoff valve.
- \* Propane Gas - 1 1/2" (31.8 mm) main supply line. One 3/4" (19mm) NPT branch per oven cavity with individual full-flow shutoff valve

Each oven includes (1) 3/4"(19mm)NPT x 36"(914mm) flexible, vinyl coated gas hose.