



IMC IMCHIP PC2 COUNTER-TOP POTATO CHIPPER - W 370 MM - 0.18 KW [KNIFE BLOCK SIZE TO BE SPECIFIED]

MODEL: F61/220



Power up your restaurant's chip making capabilities with this ultra-fast IMC Potato Chipper, which can produce 25kg of chips per minute with minimal waste. Designed to ensure short preparation times which in turn reduces costly wage bills and makes for better staff utilisation, the chipper offers interchangeable knife and scallop blocks for choice of chip size. Easy to clean, there are interlocks for operator safety and an easy-to-load hopper.

A/A FILE NUMBER:

PRODUCT OPTIONS AND ACCESSORIES

- S61/134 Blades for CS-C1/PC2 Chipper Knife Block - 12 mm x 12 mm [fits S61/135 & S61/145 blocks]
- S61/129 Blades for CS-C1/PC2 Chipper Knife Block - 14 mm x 14 mm [fits S61/114 & S61/151 blocks]
- S61/128 Blades for CS-C1/PC2 Chipper Knife Block - 17 mm x 14 mm [fits S61/115 & S61/144 blocks]
- S61/183 Blades for CS-C1/PC2 Chipper Knife Block - 21 mm x 17 mm [fits S61/182 & S61/184 blocks]
- S61/135 Knife Block - 12 mm x 12 mm - for PC2 Chipper [includes S61/134 Blade]
- S61/114 Knife Block - 14 mm x 14mm - for PC2 Chipper [includes S61/129 Blade]
- S61/115 Knife Block - 17 mm x 14 mm - for PC2 Chipper [includes S61/128 Blade]
- S61/182 Knife Block - 21mm x 17 mm - for PC2 Chipper [includes S61/183 Blade]
- S61/140 Stand for CS-C1/PC2 Chipper

PRODUCT FEATURES

- Able to produce 25kg of chips per minute
- Compact design, with flexible mounting options, to suit kitchens of any size
- Large-capacity 12kg hopper allows quick and easy loading
- One-piece knife block design for quick and safe cutting, with minimal waste
- Supplied with knife block - 12mm, 14mm, 17mm, or 21mm sizes available
- Engineered using heavy-gauge stainless steel, for longevity and easy cleaning
- UK 3 pin plug allows users to simply plug in and switch on
- Please specify a knife block at point of ordering chipper

ITEM NUMBER:



IMC IMCHIP PC2 COUNTER-TOP POTATO CHIPPER - W 370 MM - 0.18 KW [KNIFE BLOCK SIZE TO BE SPECIFIED]

MODEL: F61/220

WEIGHTS & DIMENSIONS

Width	370 mil
Depth	603 mil
Height	550 mil
Weight	40 kg

SHIPPING DETAILS

Ship Width	68 cm
Ship Depth	42.5 cm
Ship Height	84 cm
Ship Weight	44 kg
Number of Shipment Parcels	1
Ship Method	Small Parcel (FedEx, UPS, DHL)
Shipping Origin Zip Code	LN6 3QZ, UNITED KINGDOM
Quick Ship Product	No

PRODUCT CERTIFICATIONS



ENERGY SPECS

Primary Energy Type	Electric	Number of Electrical Plugs	1
Electrical Total Amperage	2.4 A	Electrical Connection Type	Cord and Plug
Electrical Volts	240V	Number of Electrical Conductor Wires	1
Electrical Total Wattage	180 W	Dedicated Circuit Required	No
Electrical Kilowatts	0.18 kW	Electrical Remarks	Single
Electrical Phase	1-Phase	Energy Saving	No
Electrical Plug Type	UK 3-Pin Plug		

ADDITIONAL SPECIFICATIONS

Airbreak	No
Control Type	On/Off
Hopper Load	12 kg
Legs or Casters	Not Applicable
Motor Power	0.24 hp
Operator Safety Method	Interlock
Processing Capacity Per Hour	1500 kg
Timer Type	No Timer

IMC reserves the right to modify specifications or discontinue models without incurring obligation. Dimensions nominal.

Document Auto-Generated
July 02, 2024





IMC IMCHIP PC2 COUNTER-TOP POTATO CHIPPER - W 370 MM -
0.18 KW [KNIFE BLOCK SIZE TO BE SPECIFIED]

MODEL: F61/220

BIDDING SPECIFICATIONS

Bidding Specifications Not Available.

TECHNICAL DRAWING

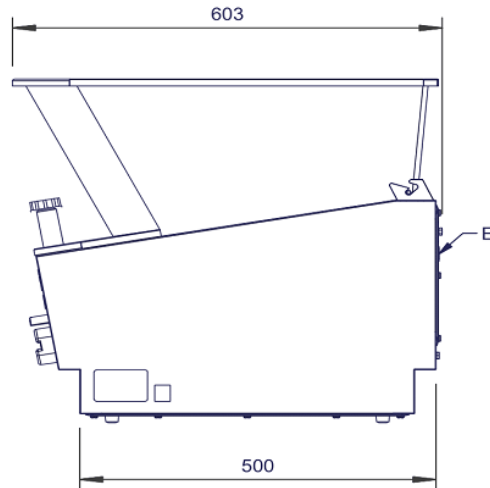
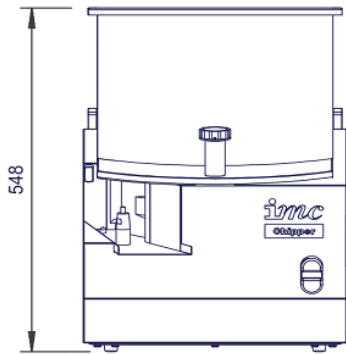
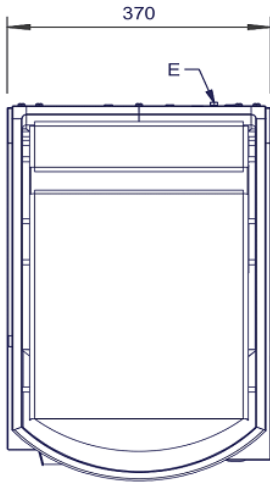

IMC reserves the right to modify specifications or discontinue models without incurring obligation. Dimensions nominal.

Document Auto-Generated
July 02, 2024

