

# HT2/HT3 Heated Trolleys

**CAUTION: Read the instructions  
Before using this appliance**



## INSTALLATION and SERVICING INSTRUCTIONS

### IMPORTANT

The installer must ensure that the installation of the appliance is in conformity with these instructions and National Regulations in force at the time of installation.

Particular attention **MUST** be paid to -

**BS7671 IEE Wiring Regulations**

**Electricity at Work Regulations**

**Health And Safety At Work Act**

**Fire Precautions Act**

This appliance has been CE-marked on the basis of compliance with the Low Voltage and EMC directives for the voltages stated on the data plate.

### WARNING -THIS APPLIANCE MUST BE EARTHED

On completion of the installation these instructions should be left with the Engineer-in-Charge for reference during servicing. Further to this, the Users Instructions should be handed over to User, having had a demonstration of the operation and cleaning of the appliance.

**IT IS MOST IMPORTANT THAT THESE INSTRUCTIONS BE CONSULTED BEFORE INSTALLING AND COMMISSIONING THIS APPLIANCE. FAILURE TO COMPLY WITH THE SPECIFIED PROCEDURES MAY RESULT IN DAMAGE OR THE NEED FOR A SERVICE CALL.**

### PREVENTATIVE MAINTENANCE CONTRACT

In order to obtain maximum performance from this unit we would recommend that a Maintenance Contract be arranged with SERVICELINE. Visits may then be made at agreed intervals to carry out adjustments and repairs. A quotation will be given upon request to the SERVICELINE contact numbers below.

This equipment is designed **FOR PROFESSIONAL USE ONLY** and be operated by **QUALIFIED** persons. It is the responsibility of the supervisor or equivalent to ensure that the user wears **SUITABLE PROTECTIVE CLOTHING**. Attention should also be drawn to the fact that some parts of the appliance will, by necessity, become **VERY HOT** and could cause burns if touched accidentally.



### WEEE Directive Registration No. WEE/DC0059TT/PRO

At end of unit life, dispose of appliance and any replacement parts in a safe manner, via a licenced waste handler.

Units are designed to be dismantled easily and recycling of all material is encouraged whenever practicable.

## Falcon Foodservice Equipment

### HEAD OFFICE AND WORKS

Wallace View, Hillfoots Road, Stirling, FK9 5PY, Scotland.

### SERVICELINE CONTACT

Phone: 01438 363 000

Fax: 01438 369 900

T100744 Ref.4

# IMPORTANT INFORMATION

## Warranty Policy Shortlist

Warranty does not cover :-

- Correcting faults caused by incorrect installation of a product.
- Where an engineer cannot gain access to a site or a product.
- Repeat commission visits.
- Replacement of any parts where damage has been caused by misuse.
- Engineer waiting time will be chargeable.
- Routine maintenance and cleaning.
- Gas conversions i.e. Natural to Propane gas.
- Descaling of water products and cleaning of water sensors where softeners/ conditioners are not fitted, or are fitted and not maintained.
- Blocked drains
- Independent steam generation systems.
- Gas, water and electrical supply external to unit.
- Light bulbs
- Re-installing vacuum in kettle jackets.
- Replacement of grill burner ceramics when damage has been clearly caused by misuse.
- Where an engineer finds no fault with a product that has been reported faulty.
- Re-setting or adjustment of thermostats when unit is operating to specification.
- Cleaning and unblocking of fryer filter systems due to customer misuse.
- Lubrication and adjustment of door catches.
- Cleaning and Maintenance
  - Cleaning of burner jets
  - Poor combustion caused by lack of cleaning
  - Lubrication of moving parts
  - Lubrication of gas cocks
  - Cleaning/adjustment of pilots
  - Correction of gas pressure to appliance.
  - Renewing of electric cable ends.
  - Replacement of fuses
  - Corrosion caused by use of chemical cleaners.

## SECTION 1 - INSTALLATION

UNLESS OTHERWISE STATED, PARTS WHICH HAVE BEEN PROTECTED BY THE MANUFACTURER ARE NOT TO BE ADJUSTED BY THE INSTALLER.

### 1.1 MODEL NUMBERS, NETT WEIGHTS and DIMENSIONS

Model	Width (mm)	Length (mm)	Height (mm)	Weight (kg)
HT2 Trolley	700	1105	1200	150
HT3 Trolley	700	1505	1200	195

### 1.2 SITING

The mobile trolleys are intended to transport hot, cooked food from kitchen to serving area.

Store, load and unload unit on a level floor.

Operate unit in a well lit area. Position trolley close to a suitable power supply in a manner that will not unduly put strain upon cable, plug and/or power socket when connected. This will facilitate easy and safe loading/ unloading of food.

### 1.3 ELECTRICAL SUPPLY

The unit is suitable for 230V~ 50Hz single phase operation only.

Mains power cable and plug is factory fitted.

The trolley relies solely on plug connection for electrical earthing. As this is a mobile unit, no additional earth provisions are available.

The unit has no ON/OFF switch. Elements/controls will be energised whenever unit is connected to mains power.

A dummy socket has been provided in trolley side panel for holding the cable and plug safely above ground and away from castors when unit is not connected to mains power supply.

**Check that no damage has occurred to the appliance, power cable and plug face during transit. If damage has occurred do not use the appliance.**

**Ensure that the mains power cable is routed free from the appliance to avoid damage.**

**We recommend supplementary electrical protection with the use of a residual current device (RCD).**

**Periodical testing, repair and fixing wiring connection should only be undertaken by a skilled and competent electrician.**

**This appliance is also provided with a terminal for connection of an external equipotential conductor. This terminal is in effective electrical contact with all fixed exposed metal parts of the appliance, and shall allow the connection of a conductor having a normal cross-sectional area of up to 10mm<sup>2</sup>. It is located on the rear panel and is identified by the following symbol and must only be used for bonding purposes.**



### 1.4 ELECTRICAL RATINGS

The HT2 heated trolley is rated at 0.92kW. Data plate is located upon rear panel.

The HT3 heated trolley is rated at 1.38kW. Data plate is located upon rear panel.

The plug is factory fitted with a 10A fuse.

## **SECTION 2 - ASSEMBLY and COMMISSIONING**

### **2.1 ASSEMBLY**

The trolley is supplied fully assembled.

Each food compartment is provided with a removable 1/1 gastronorm container rack.

Remove all packaging and dispose of waste material in a responsible manner. Recycle or re-use if possible.

### **2.2 CONNECTION TO ELECTRICITY SUPPLY**

Simply plug the unit into a 13A mains socket when in use.

### **2.3 COMMISSIONING**

Ensure there is no visual damage to any part of the trolley, including removable food container racks.

Check power cable is in good condition and cable arrest at side panel entry is effective.

Check foot-operated doors open and close easily.

Check free movement of loading racks when chamber door is fully opened.

Check brake operates smoothly. To move unit, press hand levers together. It should not be possible to move trolley when hand levers are released.

Power unit ON by plugging it into a 13A mains socket.

Power ON neon should illuminate and controller will display chamber ambient temperature in °C. 'Out1' will illuminate green.

There is no setting temperature adjustment available to user. The controller has been pre-programmed at factory for a thermostat setting of 85°C. Remove outer control cover by undoing tamperproof screws. Press controller 'set' button to check that pre-set temperature is correct.

Press 'set' again to return to operational mode with display of ambient chamber temperature. Replace outer control cover with tamperproof screws provided.

Check that elements have energised and chamber starts to heat.

A slight odour may be noticed when heating unit up for the first time. This is normal, and should not persist in subsequent use.

Unplug unit and place plug in dummy socket provided. If any damage or fault is observed these must be rectified.

After successfully completing commissioning checks, hand instructional literature to user and demonstrate correct method of use. Particular emphasis should be given to:

- Safe storage of mains cable plug by use of dummy socket in trolley side panel during transport and when not in use.
- Brake operation.
- Positioning for safe loading/unloading of food.
- How unit is powered ON/OFF.
- Pre-heat requirement.
- Operating temperature viewed on controller display.
- Indication of fault condition on controller display.
- Good practice cleaning and maintenance regime.

## **SECTION 3 - SERVICING and MAINTENANCE**

BEFORE ATTEMPTING ANY MAINTENANCE TASK, UNPLUG APPLIANCE FROM MAINS SOCKET. CARRY OUT ELECTRICAL SAFETY CHECKS ON COMPLETION OF ANY ELECTRICAL SERVICE OPERATIONS.

### **3.1 SERVICE ACCESS PANELS – TO REMOVE**

All panels are fixed with tamperproof screws. With the exception of control panel, each fixing is covered by a protective cap. Prise cap out with a flat screwdriver blade or similar implement to access screw head. When replacing caps, ensure these are in good condition and provide an effective seal against water ingress.

#### **3.1.1 Top Panel**

To remove top panel, open chamber doors. Undo fixings along front underside and rear edges.

Refit in reverse order. Fix with tamperproof screws provided and replace caps.

#### **3.1.2 Control Panel**

To remove, undo fixings at outer rim to remove outer cover. Undo panel fascia fixings. Pull panel forward to expose electrical wiring.

Refit in reverse order. Ensure gasket in side panel opening is in good condition to prevent moisture ingress. Use tamperproof screws provided.

### **3.1.3 Element Access Panel**

Element access panel is located at rear lower edge. To remove, undo fascia fixings.

Refit in reverse order. Secure using tamperproof screws provided and replace caps.

### **3.1.4 Side Panels**

To remove, undo fascia fixings.

Refit in reverse order. Fix with tamperproof screws provided and replace caps.

## **3.2 POWER SUPPLY CABLE**

Remove top panel as detailed in Section 3.1.1 to gain access to internal wire connections.

To remove cable, undo terminal connections. Loosen cable arrest in side panel and withdraw cable. Replacement cable must be to specification declared by Falcon for particular appliance.

Refit in reverse order. Ensure cable arrest is effective.

## **3.3 POWER SUPPLY TERMINAL BLOCK**

Remove top panel as detailed in Section 3.1.1 to access internal terminal block.

To remove terminal block, undo all wiring. Undo terminal block fixings.

Refit in reverse order. Ensure thermal insulation from heated chamber is in good condition. Refer to circuit diagram for correct re-wiring. Ensure integrity of all appliance earth provisions.

## **3.4 POWER-ON NEON**

If power-ON neon does not illuminate, check that this is not a sign of controller malfunction before considering replacement. Refer to Section 3.5.1 for controller fault finding.

To access neon connections, remove control panel as detailed in Section 3.1.2.

To remove neon, pull off wire terminal connections. Undo rear fixing nut and withdraw neon.

Refit in reverse order.

## **3.5 TEMPERATURE CONTROLLER**

### **3.5.1 Fault Finding**

There is no setting temperature adjustment available to the user. Controller has been pre-programmed at factory for a thermostat setting of 85°C. When switching power ON to appliance, controller display will be going through an initialisation process lasting a couple of seconds before settling into its operating mode.

Under normal operation ambient chamber temperature at controller probe location will be displayed. Once fully pre-heated, chamber temperature will cycle around this value as elements are switched ON/OFF to maintain set temperature. "Out1" will illuminate green when elements are energised.

Empty chamber cycle normally remains within 10° of this setting. Refer to User Instructions for further performance comments.

If 'PR 1' is flashing on display the probe or its electrical connections are defective. Check integrity of probe wire connections to controller before considering replacement. Wire connections can either be accessed by removing top panel as Section 3.1.1 or control panel as Section 3.1.2.

Power ON neon going OFF for longer periods in combination with wide temperature swings signifies the thermal limiter is activated. Check thermostat setting and whether controller is shorted out of circuit before considering replacement.

To check pre-programmed thermostat setting, remove outer control cover by undoing tamperproof screws. Press controller 'set' button to check that pre-set temperature is correct. Press 'set' again to return to operational mode with display of ambient chamber temperature. Replace outer control cover with tamperproof screws provided.

### **3.5.2 To Replace Controller**

Remove control panel as Section 3.1.2.

To remove controller, disconnect wires. Depress locking tabs of mounting bracket at side of controller and slide off to rear. Withdraw controller forward through panel.

Re-fit in reverse order. Ensure mounting bracket locking tabs are engaged. Refer to circuit diagram for correct re-wiring.

### **3.5.3 To Replace Probe**

Remove top panel as Section 3.1.1. Disconnect probe connections at rear of controller. At probe end, carefully lift away thermal insulation and undo chamber seal. Probe sensor is fitted within the chamber compartment roof divider channel. From inside chamber, undo probe and guard fixings to feed out through roof aperture.

Re-fit in reverse order. Ensure roof probe is correctly located. Re-seal at roof aperture and fully restored thermal insulation on top of chamber before re-fitting top panel. Check temperature controller operation.

### **3.6 THERMAL LIMITER**

A self-resetting thermal limiter is fitted to the unit to protect components from further damage should controller operation fail while elements are energised.

To access device, remove top panel as Section 3.1.1. Thermal limiter is attached to top of heating chamber.

To remove device, carefully lift thermal insulation in the vicinity of limiter body. Pull off wire terminal connections and undo mechanical fixings.

Re-fit in reverse order, applying heat sink compound between limiter and chamber surfaces. After accessing component, ensure thermal insulation is fully restored before re-fitting top panel.

### **3.7 ELEMENTS**

Remove element access panel as Section 3.1.3.

Pull off element terminal connections. Undo element tray fixings. Slide tray out. Elements may now be removed.

Refit in reverse order, ensuring both electrical and mechanical connections are securely fixed.

### **3.8 DOOR CATCH MECHANISM**

Refer to **Figure 1**. (*Page 7*)

To remove door stop spring mechanism, tee-bar must be fully unscrewed. Depress door stop to bring tee-bar down below mounting plate edge. Unscrew tee-bar. Door stop mechanism can then be withdrawn and spring and washer removed. When replacing, ensure washer is located below the spring against base.

To remove foot pedal and mounting plate, first unscrew tee-bar sufficiently to clear mounting plate. Undo fixings on underside of base. Refit in reverse order.

Adjust tee-bar as required to ensure satisfactory door operation. Door stop engages with roller attached to bottom edge of door.



### 3.9 BRAKE MECHANISM

Refer to **Figures 2 and 3.** (Page 7)

To adjust tension on brake cable:

Remove lower control panel below brake handle. Use nut on underside to adjust to required tension. Replace in reverse order.

If further adjustment is required:

Loosen brake cable terminal at castor. Pull cable tight.  
Re-tighten cable terminal. Replace in reverse order.

To replace cable: Cut off cable nipple.

Loosen cable terminal.

Pull cable free from sheath. Replace in reverse order.

### 3.10 CASTORS

**Note:** This unit is heavy.

**Note:** Refer to Section 1.1 for nett weights. Take due care when replacing castors. Unit may be jacked up or lifted upon blocks to allow safe removal of castor(s). Alternatively, an empty trolley may be laid on its back provided appropriate lifting assistance is available to do this in a safe and controlled manner.

**Note:** Always replace castor with correct specification variant for the given position.

**To remove Castor:** Undo fixings on underside of trolley to remove. Refit in reverse order.

To remove Castor with Brake: Loosen tension of cable before release from castor brake mechanism. Replace in reverse order.

To set brake tension, tighten turnbuckle to top and release by a half turn. Lock in place with nut. Regrease mechanism at handle bar and castor. When trolley is resting on all castors, ensures brake operates smoothly. It should not be possible to move trolley when hand levers are released. Adjust screw link if necessary. Re-fit side panel when satisfied brake operates correctly.

### **3.11 DOOR**

To remove door, undo top door hinge fixings. Swing door open and lift off bottom hinge.

To remove door catch roller bar assembly, undo locknut to remove securing pin and roller.

Re-fit in reverse order. Check door operates as required.

### **3.12 DOOR with DOOR SEAL**

Remove door as detailed in Section 3.11.

To remove door seal, undo fixings on inner door panel. When refitting seal, start at bottom of door. Fit in stages while securing inner panel. Make triangular cuts into seal flange to form bends at corners. Apply sealant at seal joint.

### **3.13 CHAMBER DOOR SEAL**

Use a Ø4.5mm drill to remove aluminium rivets.

Re-use metal strips and rivet replacement seal to chamber.

### **3.14 DUMMY SOCKET**

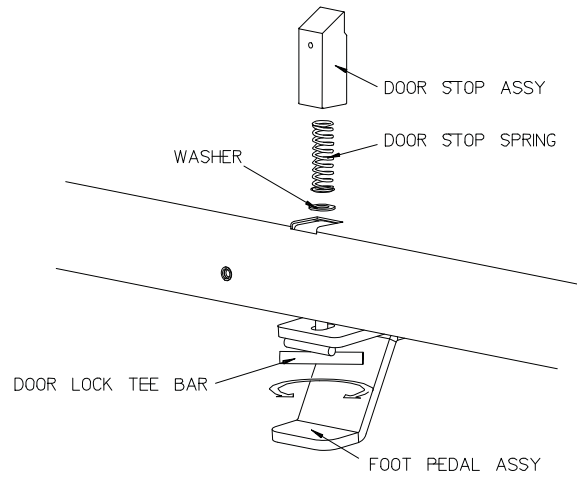
Loosen mains power cable arrester. Remove side panel fixings as Section 3.1 and open panel. Take care not to put strain on power cable.

To remove socket, depress assembly fixing tabs and withdraw through stiffening plate and panel.

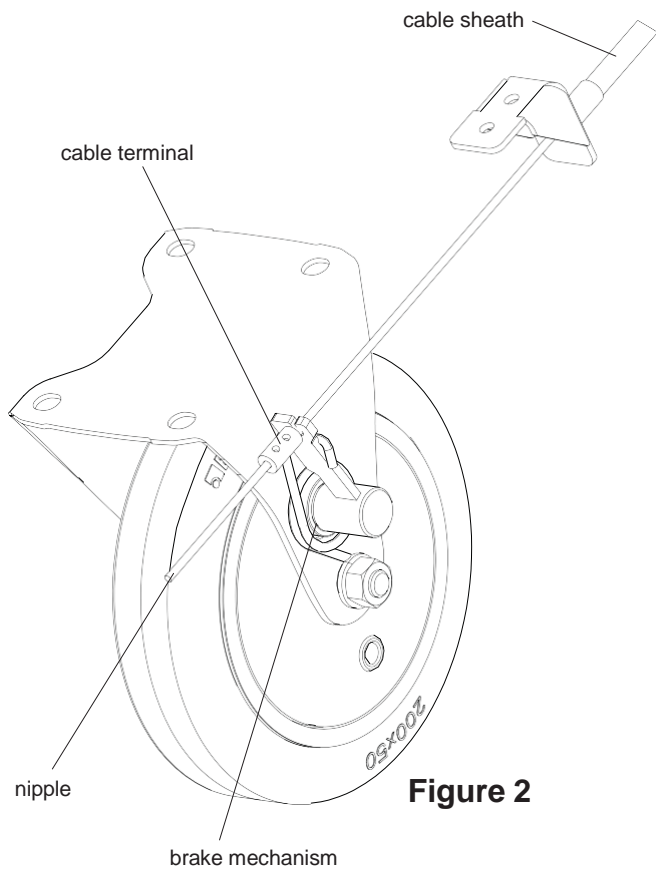
Re-fit in reverse order, making sure stiffening plate is fitted. Ensure cable arrest is effective.

## **SECTION 4 - SPARES**

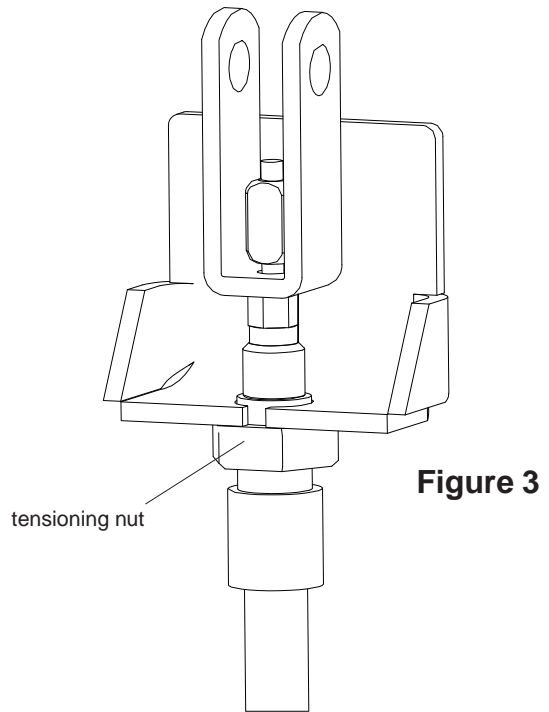
When ordering spare parts, always quote unit type and serial number. This information can be found on appliance data plate located upon appliance rear panel.



**Figure 1**

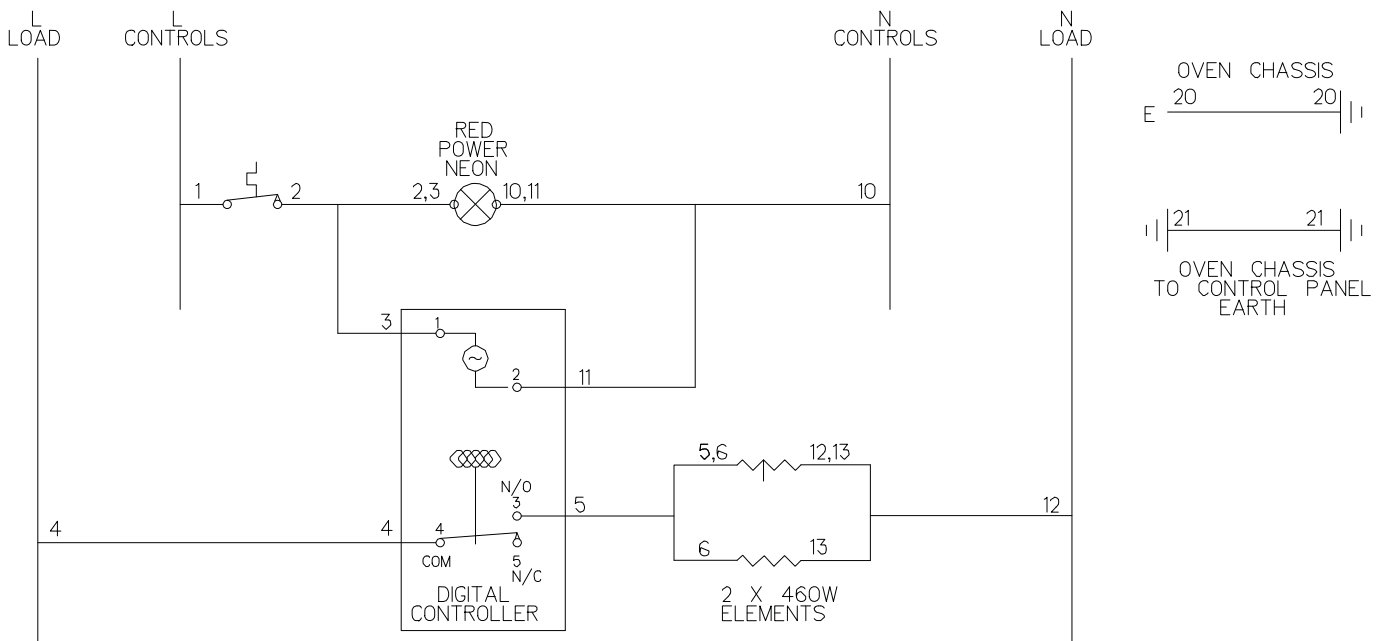


**Figure 2**



**Figure 3**

## HT2 CIRCUIT DIAGRAM



## HT3 CIRCUIT DIAGRAM

