

MTE30



Installation	Free Standing
Category	One Door
Cooling type	Static
Defrost	Automatic
Technology type	Thermoelectric
Hinge type	Standard
Hinge position	Right
Reversible door	Yes
EAN code	8017709312534



Target

Industries	Hotels
------------	--------

Aesthetics

Colour	Black
Material	Plastic
Handle	Integrated
Logo colour	Chrome
Side material	Steel
Side colour	Black
Logo	Silk screen

Refrigerator compartment features



No. of adjustable shelves	1
Type of adjustable shelves	Glass
Internal light in fridge	Yes
Type of internal light (fridge)	LED

Refrigerator Inner Door

Number of adjustable door shelves	1
No. of bottle shelves	1

Other technical features

Refrigerant gas type	R600a	Refrigerant Quantity (gr)	25 g
----------------------	-------	---------------------------	------

Performance / Energy Label

Noise level	23 dB(A) re 1 pW
-------------	------------------

Performance / Energy Label



Annual energy consumption	131 kWh/a
Energy efficiency class	G
Airborne acoustical noise emission class	A
Total volume	20 l
Sum of the volumes of the chill compartment(s) and the unfrozen compartment(s)	20 l
Total volume	30 l
Climatic class	N
EEL	168 %

Electrical Connection

Nominal power	65 W
Voltage (V)	230 V
Frequency (Hz)	50/60 Hz
Power supply cable length	150 cm
Plug	(F;E) Schuko

Logistic Information

Width (mm)	384 mm
Depth without handle	375 mm
Product Height with feet	468 mm
Product width with maximum doors opening	567 mm
Product depth with doors open at 90°	742 mm
Dimensions of the product (WxDxH)	384x375x740 mm
Packed product dimensions (WxDxH)	455x475x505 mm

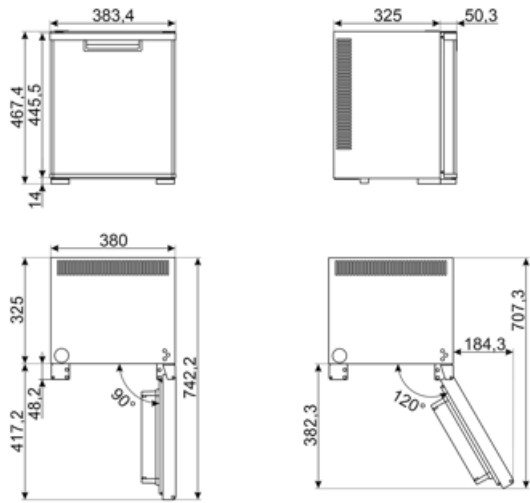

Symbols glossary



The automatic defrost system works by automatically defrosting at regular intervals eliminating the need to defrost altogether.



LED interior lighting: is a more energy efficient and long lasting way of illuminating the interior of the appliance.



Energy efficiency class G

Benefit

The R600a refrigerant, with a low environmental impact, ensures rapid cooling and reduced energy consumption.

The integrated handle optimises space and reduces the risk of bumps thanks to the absence of protrusions. Additionally, the continuous surface makes cleaning easier.

The internal lighting ensures optimal visibility of the shelves, improving organisation within the fridge compartment.

Automatic defrosting prevents ice build-up and reduces the need for manual intervention, improving reliability and service continuity.