

Overview

Hot conveyance trolleys fitted with Moffat's renowned innovative sahara fan heating cell. Easily removable for cleaning and maintenance. The energy efficient hot trolley is controlled by a 30° to 110° thermostat. Available with the capacity for 6, 12, or 20 level 1/1 GN containers or wire shelving. Each model is fitted with corner bumpers, transport handles, locking castors and a single solid lockable door. There is also a humidification tray. Designed to maintain pre-heated, cooked food at a regulated temperature. Suitable for the holding of most types of hot food.

**Key Features:**

- Fast heat up and recovery time
- Thermostatically controlled.
- Unique, removable, forced air heating cell.
- Low maintenance, easily cleaned, and highly efficient
- 3 models in the range holding 6 to 20 GN 1/1 gastronorm type containers.
- Various mixed sizes of gastronorm pans can be used in unison.
- 24 hour operation
- Plug and Go, complete with 2 metre long power cable and 13amp plug
- Fully insulated
- Mobile with all swivel castors, two are fitted with brakes.
- Lockable doors

Options:

- Gastronorm containers



This unit features
Moffat's renowned,
Sahara fan heating
cell & easy-lift pan lip.

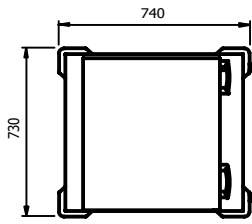

PF6

Model	Weight (kg)	L x W x H (mm)	Electrical Supply	Power Rating (kw)	Shelf pitch
PF6	70	740 x 730 x 880	13amp	0.9	80
PF12	89	740 x 730 x 1360	13amp	1.9	80
PF20	130	740 x 730 x 1800	13amp	1.9	70

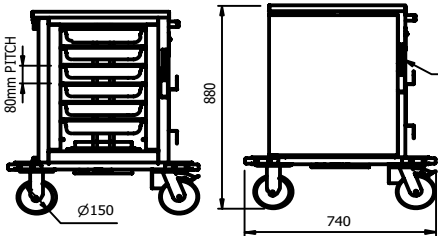

INTERIOR SHOWN WITH DOOR OPEN

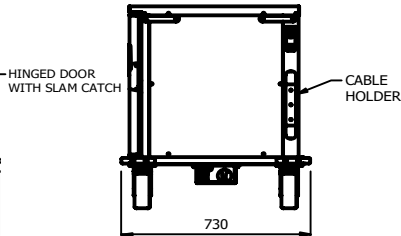

PF6

PF12

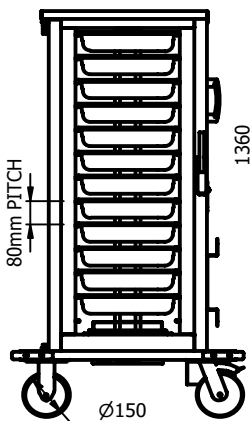

INTERIOR SHOWN WITH DOOR OPEN

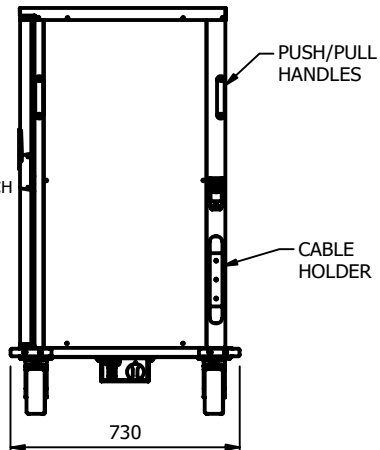
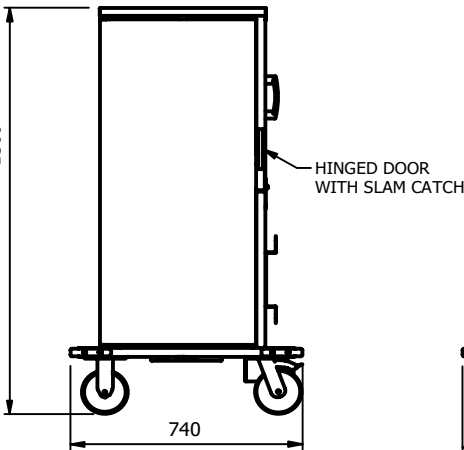

PF20

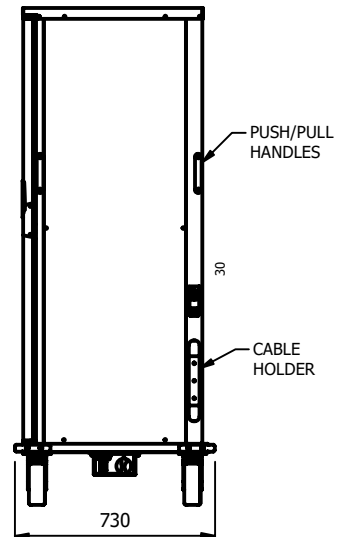
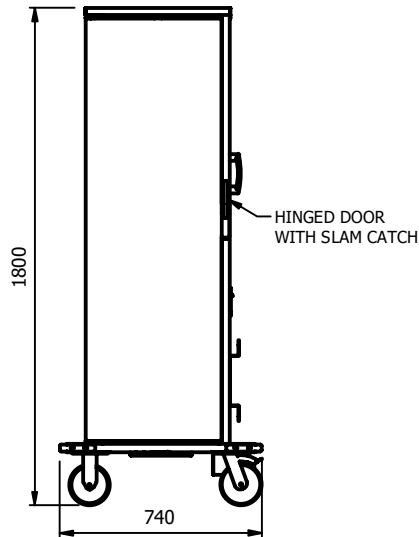
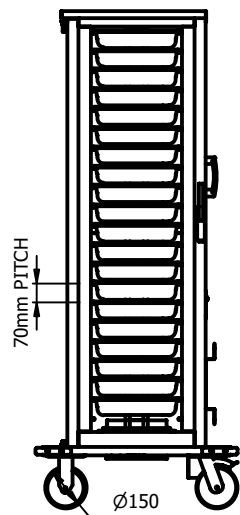

MADE IN BRITAIN

E&R Moffat Ltd.
Bonnybridge
FK4 2BS
Scotland

Find us on:



1963 - 2018

www.ermoffat.co.uk
+44 (0) 1324 812272
sales@ermoffat.co.uk