

Engineers' manual

Under counter machines



Technical Support	+44 (0) 1889 272337
Spare Parts	+44 (0) 1889 272340
Service	+44 (0) 1908 359059
Sales	+44 (0) 1889 272338

Table of Contents

1.	INTRODUCTION.....	3
1.1	INSTALLATION AND COMMISSIONING.....	3
1.2	SERVICE AND REPAIRS.....	3
1.3	MODIFICATION.....	3
2.	EXPLANATION OF SYMBOLS USED.....	3
3.	WARNING AND SAFETY INFORMATION.....	3
3.1	DANGER WARNINGS.....	3
3.2	WARNINGS.....	3
3.3	CAUTIONS.....	3
4.	MACHINE SPECIFICATIONS.....	4
4.1	SYSTEMS MATRIX.....	4
4.2	MECHANICAL SPECIFICATIONS AND SITE REQUIREMENTS.....	4
4.3	WIRING.....	4
4.4	COMPONENTS.....	4
4.4.1	<i>Pump wiring.....</i>	<i>5</i>
5.	WATER PATHS.....	6
5.1	STANDARD SYSTEM – C400 & C500.....	6
5.2	WATER SOFTENER SYSTEM – C400WS & C500WS.....	7
5.3	WATER SOFTENER UNIT.....	8
5.4	WATER WAYS LEGEND.....	9
6.	LOGIC.....	10
6.1	INDICATOR LOGIC.....	10
6.1.1	<i>Heating indicator.....</i>	<i>10</i>
6.1.2	<i>Cycle indicator.....</i>	<i>10</i>
6.1.3	<i>Display indicator.....</i>	<i>10</i>
6.2	FILL AND HEAT.....	11
6.3	WASH AND RINSE.....	12
6.4	DRAIN.....	12
6.5	CHEMICAL DOSING.....	14
6.6	WATER SOFTENER UNIT.....	14
7.	SERVICE SETTINGS.....	15
7.1	SERVICE INTERFACE.....	15
7.2	COMMISSIONING AND CUSTOM SETTINGS.....	15
7.3	SERVICE MODE.....	15
7.3.1	<i>Parameters.....</i>	<i>17</i>
7.3.2	<i>Errors.....</i>	<i>23</i>
7.3.3	<i>Statistics.....</i>	<i>25</i>
7.3.4	<i>Load Activation.....</i>	<i>26</i>
7.3.5	<i>Diagnostics.....</i>	<i>27</i>
7.3.6	<i>Machine Data.....</i>	<i>27</i>
7.3.7	<i>Update Menu.....</i>	<i>28</i>
8.	CONTROL UNIT.....	29
8.1	INPUTS AND OUTPUTS.....	29
8.1.1	<i>Main board.....</i>	<i>29</i>
8.2	BOARD SETUP.....	31
9.	CABLE REPAIR KITS.....	32
	AVAILABLE CABLE KITS LIST.....	32

10.	TOOL LIST.....	32
11.	NOTES.....	33
12.	MACHINE RATING.....	34

1. Introduction

Prior to reading this manual it is essential that you are familiar with the contents and subject matter covered by the "**Installation and Operation manual**".

1.1 Installation and commissioning

Installation and commissioning instructions are detailed in the "**Installation and Operation manual**" and should always be followed. Incorrect installation may invalidate any warranties.





1.2 Service and repairs

Repairs to the machine should only be carried out by a **Classeq** approved/trained technician using genuine **Classeq** parts. Failure to do so may invalidate any warranties.

1.3 Modification

Classeq reserves the right to modify the machine or the contents of this manual without notice.

2. Explanation of symbols used

 DANGER!	Warning against potentially serious or fatal injuries to persons if the described precautionary measures are not taken.	▶	This symbol refers to a chapter with more detailed information
 Warning!	Warning against potentially minor injuries to persons or material damage if the described precautionary measures are not taken	1	Refer to foot note at bottom of page
 Caution	Warning against defects in or destruction of the product if the described precautionary measures are not taken.		Recycle

3. Warning and safety information

3.1 Danger warnings

Unless the machine has been isolated from the supply there will always be potential for mains voltage to any components in the machine. (▶ 8)

3.2 Warnings

DO NOT run the machine if there is no salt in the salt reservoir, as this will allow lime scale to build up, also any lime scale will invalidate your warranty.

DO NOT add any chemicals, such as detergent or rinse aid to the reservoir. These will cause damage to the machine.

3.3 Cautions

Only use granulated salt (*max. grain size 5 – 7 mm*). Salt tablets are not suitable.

If the reservoir cap is not properly secured, water and/or chemicals can leak in or out of the unit causing damage to the machine.

Repairs to the machine should only be done with the mains supply isolated. (▶ 8)

Any changes made to P30 will not be saved if power to the machine is disrupted before completely exiting service mode. (▶ 8.2)

4. Machine specifications

4.1 Systems matrix

Below is a table describing the various systems available for the different machine types.

Machine type	13A (11A ¹)	28A	3 Phase	Rinse booster pump	WRAS approved air gap	Water softener	Drain pump
C400	●	●	●	●	●	○	●
C400WS	●	●	●	●	●	●	●
C500	●	●	●	●	●	○	●
C500WS	●	●	●	●	●	●	●

● - Standard

◐ - Optional

○ - Not available

4.2 Mechanical specifications and site requirements

For details on machine dimensions and site requirements refer to the “**90001697 User Manual**” for the machine.

4.3 Wiring

For detailed wiring information refer to the wiring diagram “**30018142 wiring diagram UC**”. It is available online on Classeq’s website to download or view. You can also find wiring diagram on the lower front panel’s inner side.

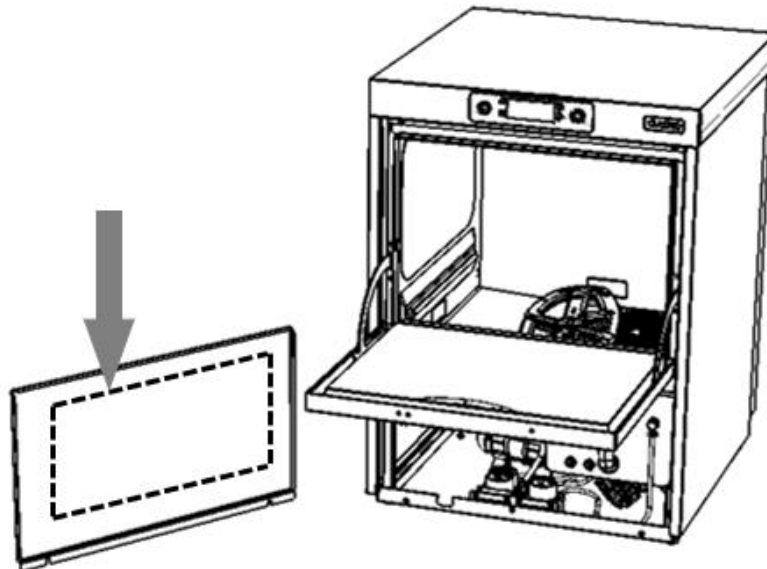

4.4 Components

The table below indicates the electrical components in the machines and their electrical specifications.

Component		Voltage range (V)	Frequency (Hz)	Current (A)	Power (W)	Resistance (Ω)
Inlet solenoid		220-240	50/60	0.026	6	4110
Rinse element	6000 W	220-240	50/60	8.68	3 x 2000	27.25
Rinse Pump		220-240	50	0.7	190	M – 32.2 A – 43.3
		220-240	60	0.66	146	M – 26.78 A – 34.8
Wash element		220-240	50/60	8.7	2000	27.3
Wash Pump		220-240	50	2.55	580	M – 9.52 A – 18.97
		220-240	60	2.42	550	M – 8.06 A – 16.11
Drain pump		220-240	50	0.2	30	145.1
		208-240	60	0.15	32	76
Relay	3 Pole	220-240	50/60	0.006	1.3	6760
Detergent pump		220-240	50/60	0.03	8	3180
Rinse aid pump		220-240	50/60	0.03	8	3180

4.4.1 Pump wiring

The windings of the wash and rinse pumps are wired to the plug as below:

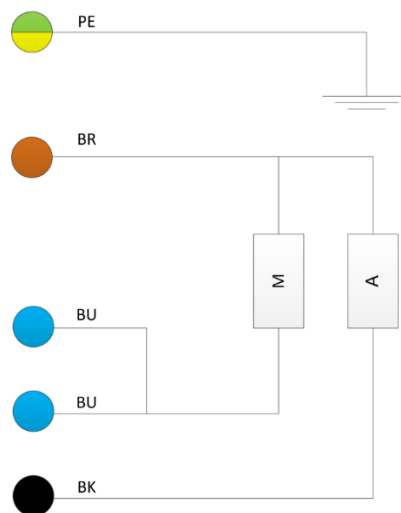

Key	Description
M	Main winding
A	Auxiliary winding
PE	Earth wire (Green and Yellow)
BU	Blue wire
BK	Black wire

5. Water paths

5.1 Standard system – C400 & C500

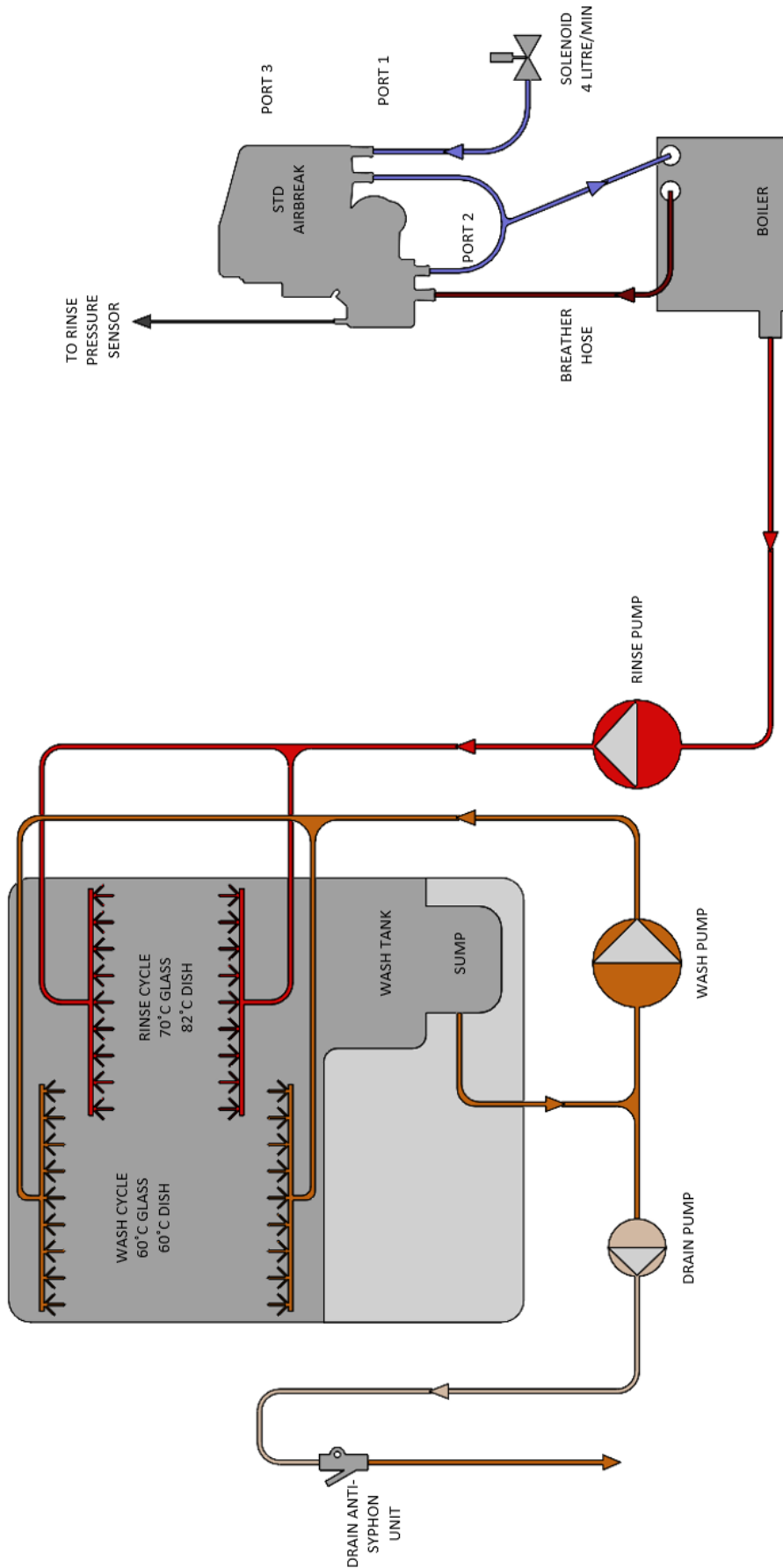



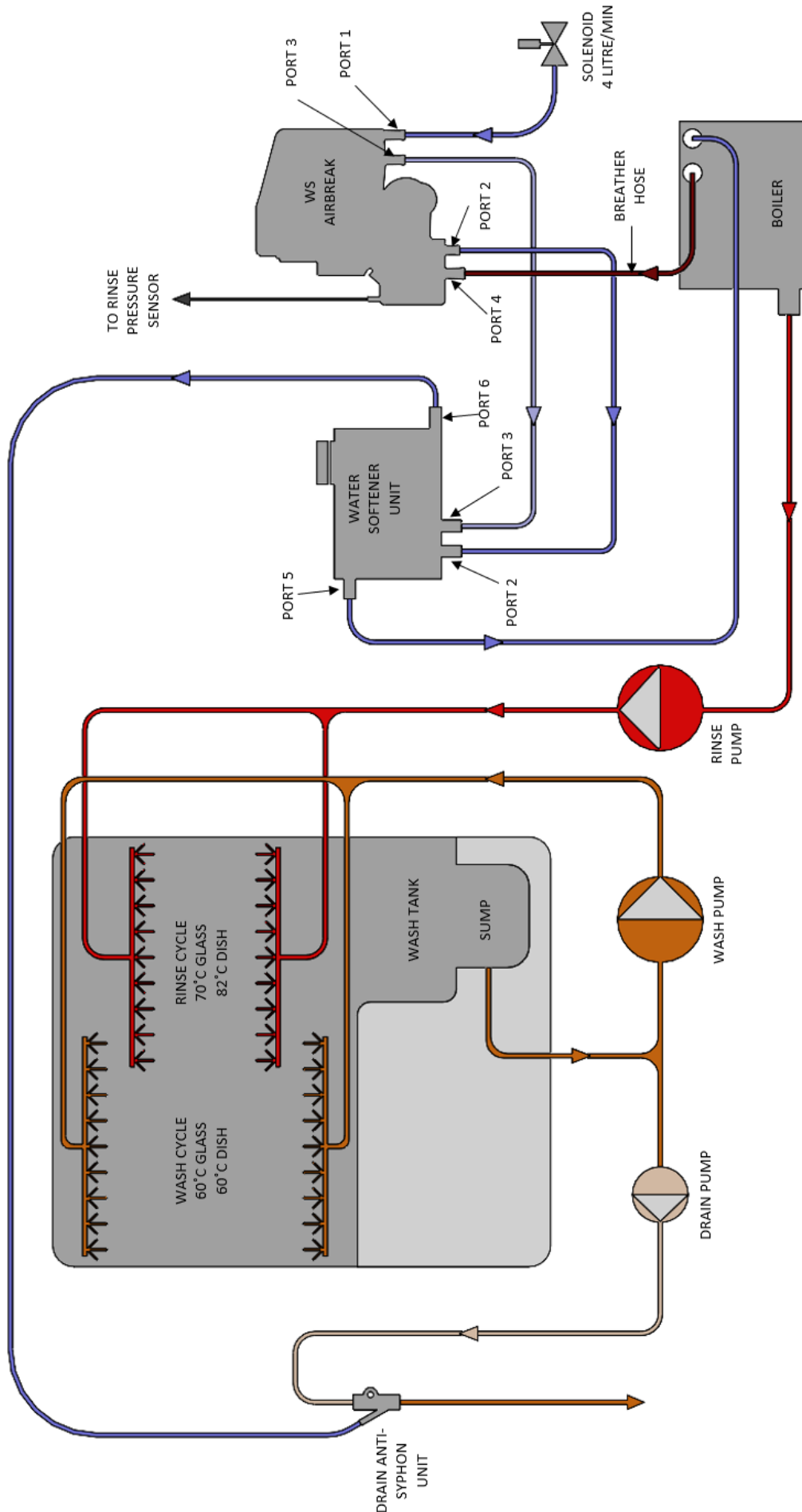

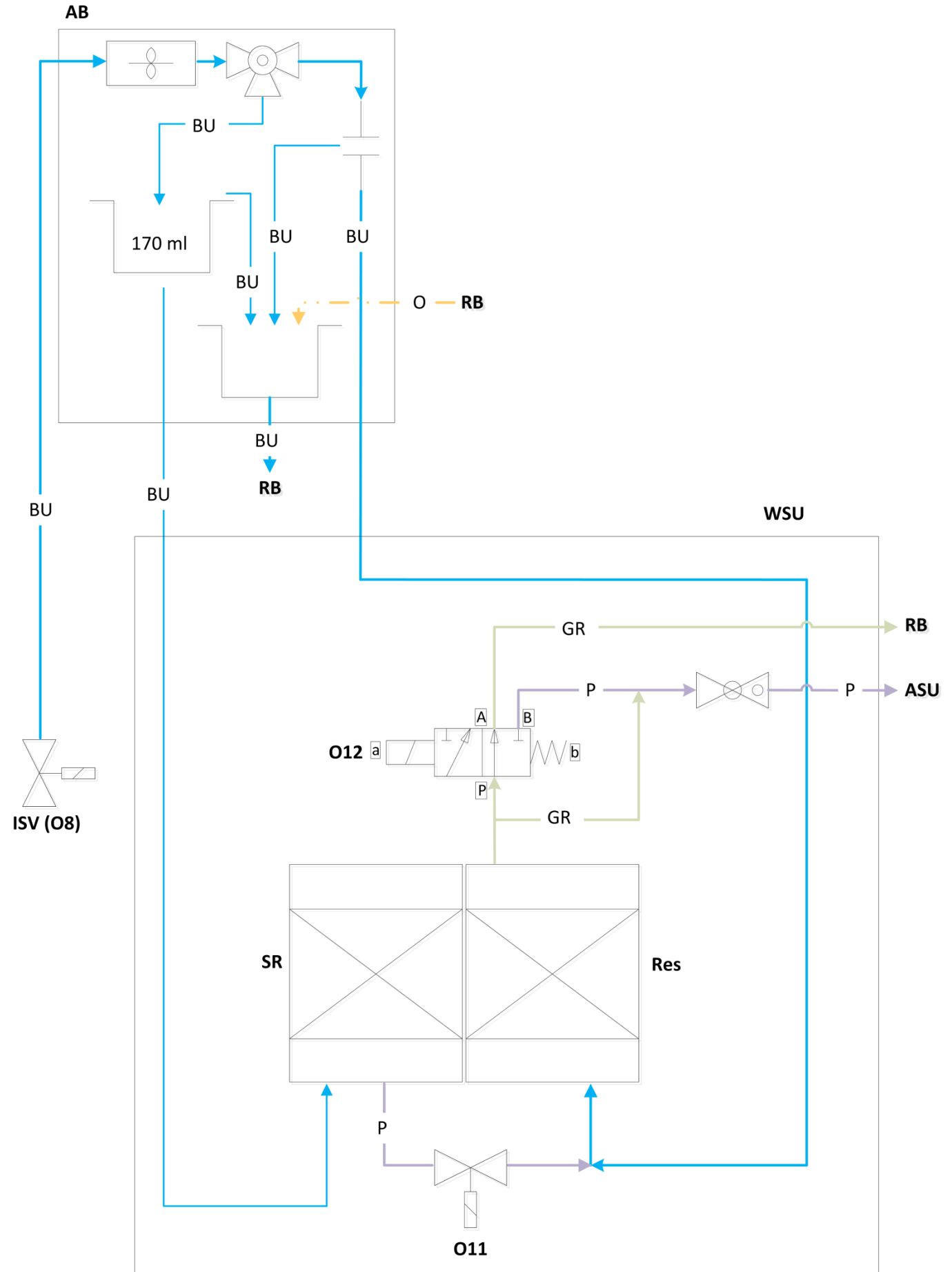

5.2 Water softener system – C400WS & C500WS

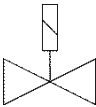
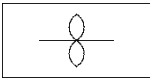
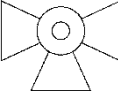

5.3 Water softener unit

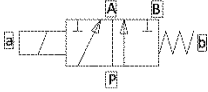

5.4 Water ways legend

Key	Description
ISV	Inlet solenoid valve
AB	WRAS approved type AB air gap
RB	Rinse tank
WSU	Water softener unit
ASU	Anti-syphon unit
SR	Salt reservoir
Res	Resin chamber
	Solenoid valve
	Paddle sensor
	Ball valve
	Air gap
	Switching valve
	Non return ball valve
BU 	Incoming water
GR 	Softened water
P 	Waste water – Water softener

6. Logic

6.1 Indicator logic

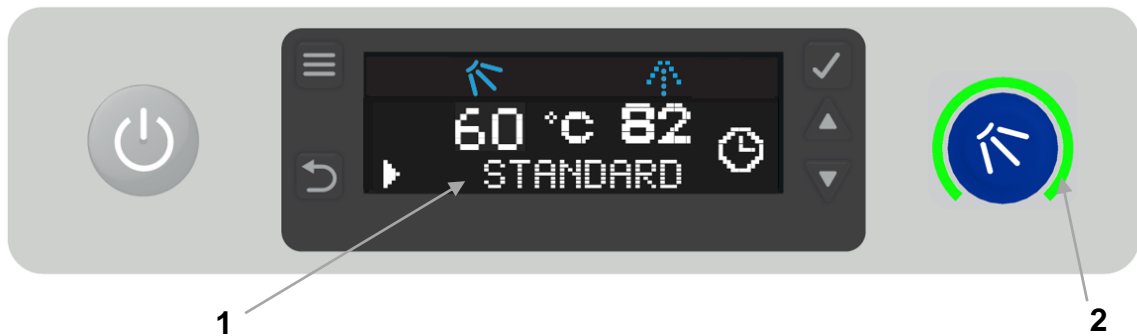

Item	Description
1	Display Indicator
2	Heating/Cycle indicator

6.1.1 Heating indicator

This will illuminate **GREEN** only when following condition is achieved:

- Wash tank water level full
- Rinse tank water level full

If one of these has not been achieved the indicator will flash **AMBER** to indicate that the machine has not achieved these.

6.1.2 Cycle indicator

This will illuminate **BLUE** when a cycle has been requested. The cycle will then start when the above interlock requirements have been achieved.

In certain serious error conditions this indicator will illuminate **RED** and the machine will turn off.

6.1.3 Display indicator

This will display active state of the machine.

During filling and heating	
Standby Mode	
Cycle Mode	
Drain Mode	

6.2 Fill and heat.

Unpressurised (air gap) machines fill and rinse using a rinse booster pump; this means that the rinse is not reliant on the incoming water pressure. These machines fill in the following manner:

- 1) Activate solenoid valve to fill rinse tank.
- 2) When rinse tank has reached the minimum level, it will start to heat to a specified transfer temperature; this is lower than the rinse temperature to ensure that the wash tank is not too hot after the fill cycle.
- 3) Activate the rinse booster pump to transfer water for a specified time.
- 4) Repeat steps 1 to 3 until the wash tank is full.
- 5) Once the wash tank has reached a minimum level this will begin to heat if required while the rinse tank is refilling.
- 6) On machines with water softeners fitted the machine will calculate the volume of water that has passed through the unit and activate the regeneration process (► 6.6) as required.
- 7) Once wash tank water level and Rinse tank water level is achieved, **GREEN** lamp will illuminate.
- 8) In the background machine will continue to heat until the rinse boiler and wash tank have both reached the specified temperatures.

Below is a flow diagram to represent this.

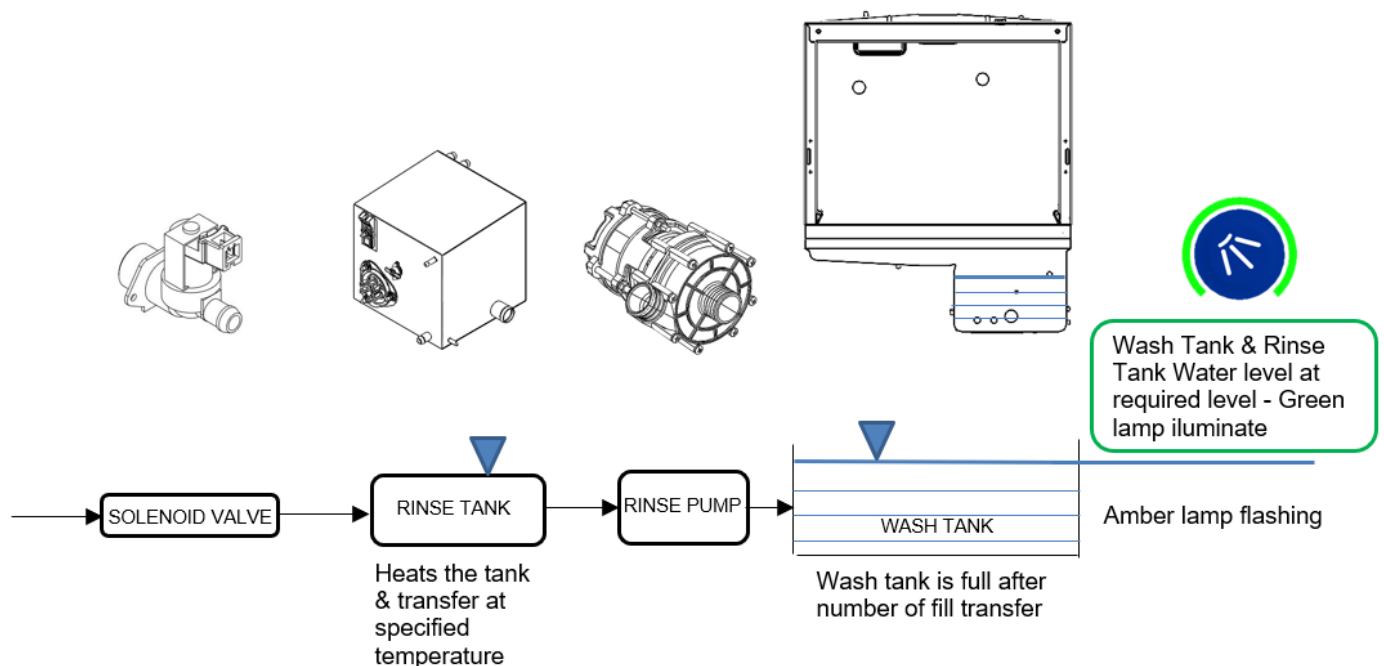

6.3 Wash and rinse

If a cycle is requested when the machine is in standby the wash and rinse, process on all machines, follow the below procedure:

- 1) BLUE lamp is illuminate on cycle indicator.
- 2) Starts the wash cycle with wash pump activated. Soft start runs i for first 6 seconds.
- 3) Once the wash tank and rinse tank has achieved the interlock temperature (P41&P51) and the wash time has elapsed, Wash pump will be deactivated. If the interlock temperature is not satisfied during wash cycle time than it will extend the wash cycle till it has achieved, it.
- 4) There is a pause of 8 seconds to allow the wash tank water to drip down back in wash tank.
- 5) Completes the rinse cycle for the specified time (P60) with activation and deactivation of Rinse pump.
- 6) There is a short pause after the rinse to allow water to drip down then the Cycle indicator will turn to Green or Amber.

Below is a flow diagram to represent this.

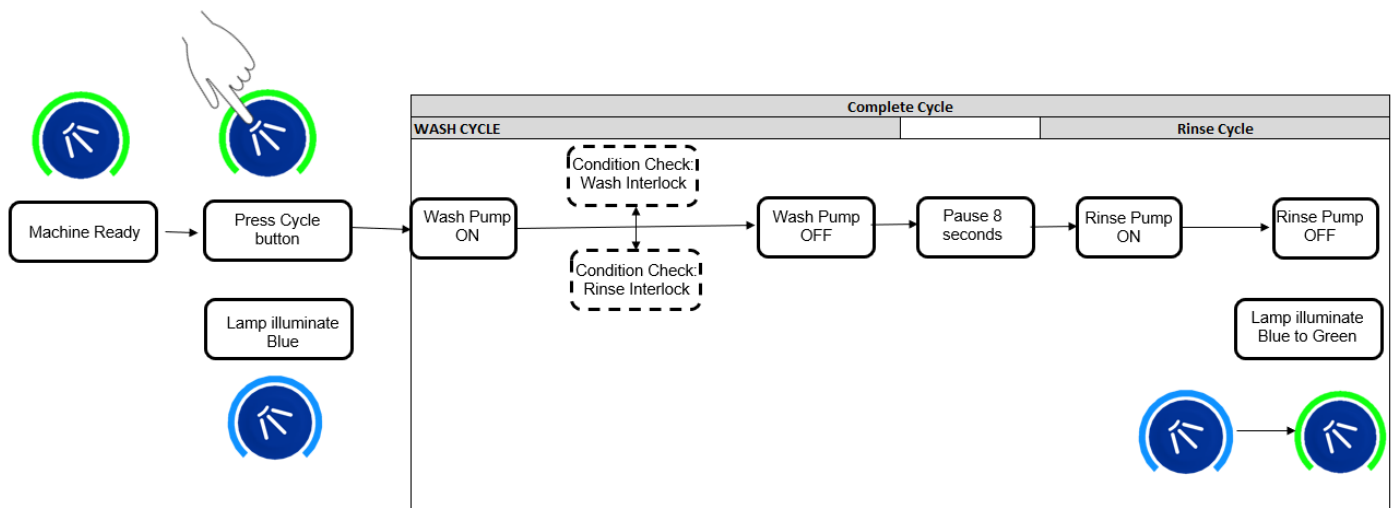

Refer (►7.3.1) for more information on Parameters P41 & P51 and interlock options. Please note if condition for either P41 or P51 not met during specific wash cycle time than it will extend the wash cycle time till it satisfies the conditions.

6.4 Drain

The drain of the machine functions in two ways:

1. It monitors the water level in the wash tank and drains away any excess water at any time.
2. If the machine is turned off and the drain cycle is selected, this function will follow the below process:
 - a. Start draining the machine.
 - b. Once the water reaches the minimum level in the wash tank an "Assisted clean" function will transfer water from the rinse boiler in the same fashion as it fills (►6.2) while continuing to drain (If the door is open at this time the "Assisted clean" will be cancelled).
 - c. Once the wash tank reaches a minimum level again it activates a timer to drain out the remaining water.

Below is a flow diagram to represent this.

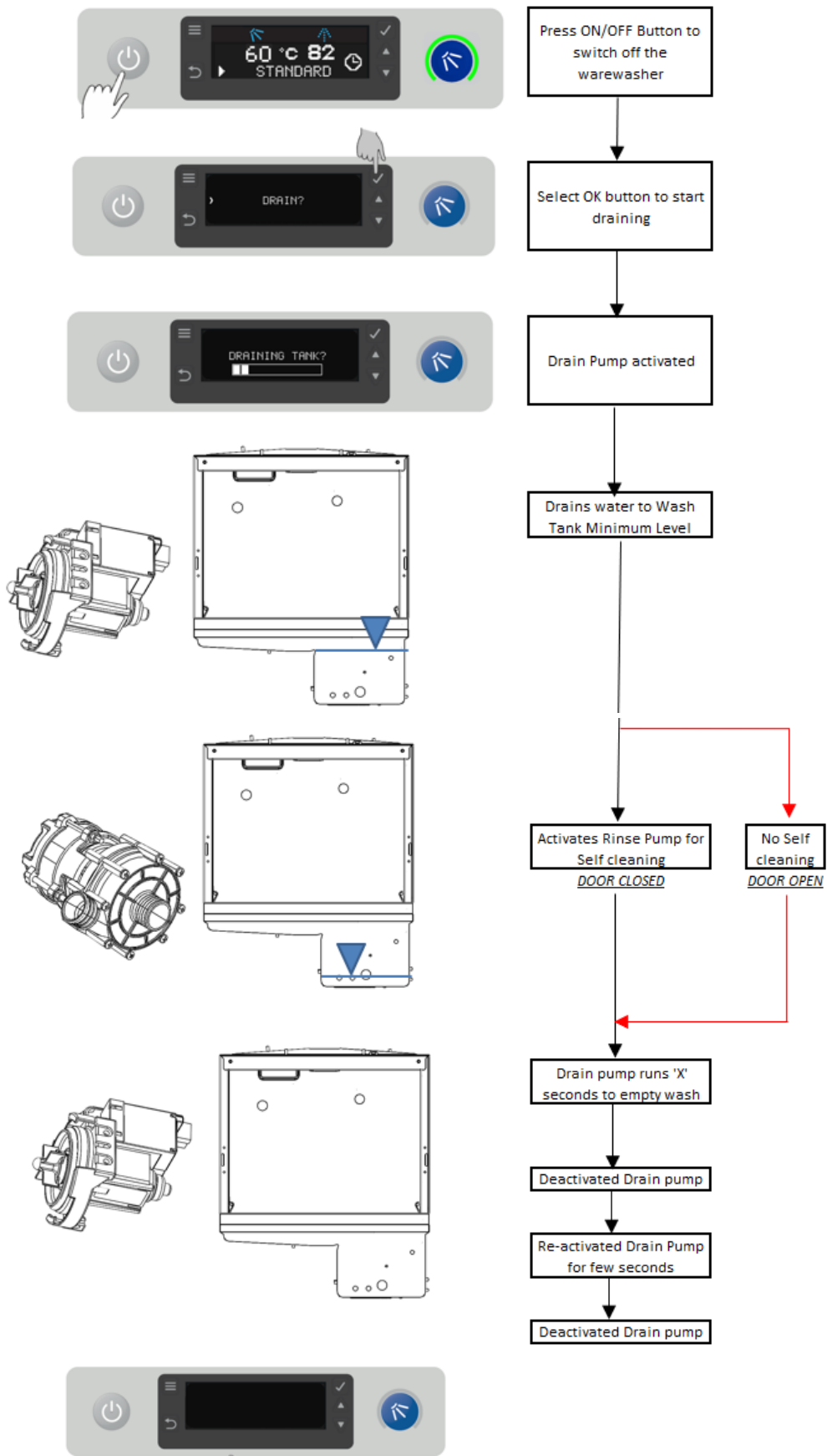

6.5 Chemical dosing

The machine doses chemical at two different stages:

1. While filling the machine:
 - a. The detergent is dosed into the wash tank with each transfer. At the end of the fill the rinse aid is dosed into the rinse tank.
2. While cycling the machine:
 - a. When a cycle is selected the detergent will dose into the wash tank. This will not occur on the first cycle after filling the machine.
 - b. After each cycle the rinse aid is dosed into the rinse boiler as per water used during cycle.

6.6 Water softener unit

On machines with the integral water softener fitted the machine will monitor the amount of water passing through the resin of the softener unit and regenerate at intervals required by the water hardness setting.

The regeneration process passes salt water into the resin, allows a contact period for the salt to 'scrub' the resin then flushes this salt water out the waste.

 Re-fill salt indicator will flash to indicate water softener needs salt re-filling. Refer (► 3.3) for Salt specification and unit installation and operation manual for more information.

Below is the timing for this function of the water softener unit.

Function	Rinse until resin exhausted	Pause	Salt to resin	Pause	Pressurise	Regen (Contact)	Pause	Flush	Pause
Time		3s	25s	3s	1.5s	20s	3s	20s	3s
ISV (O8)									
WS salt valve (O11)									
WS waste valve (O12)									

7. Service settings

7.1 Service interface

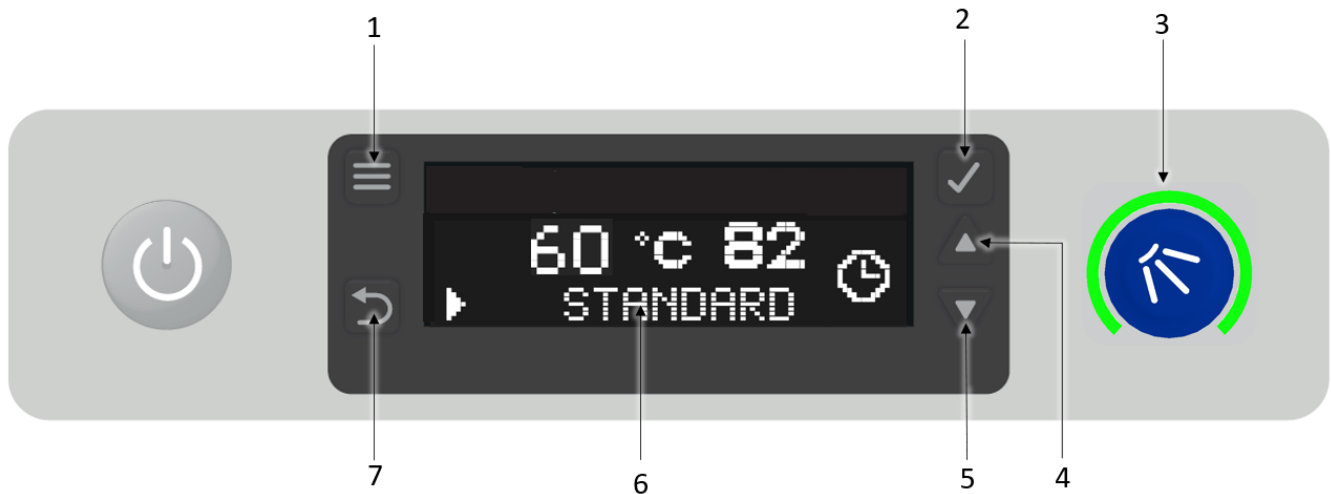

Item	Description
1	Menu button
2	Enter/Select button
3	LED indicator
4	UP Button
5	DOWN button
6	State Display
7	Back button

Press Menu button (1) to Enter the Service Mode and Back Button (7) to come out of Service Mode. UP and DOWN buttons (4 & 5) are to scroll the options.

7.2 Commissioning and Custom settings

Please refer "[**User Manual**](#)" which covers commissioning and custom settings topics.

7.3 Service mode



These settings can only be access by qualified electrician or Technician. Failure to do can result in warewasher malfunction. Always make a note of previous settings before making any changes.

Contact Classeq Technical for more information.

Service mode can be accessed during filling, standby and cycle MODE.

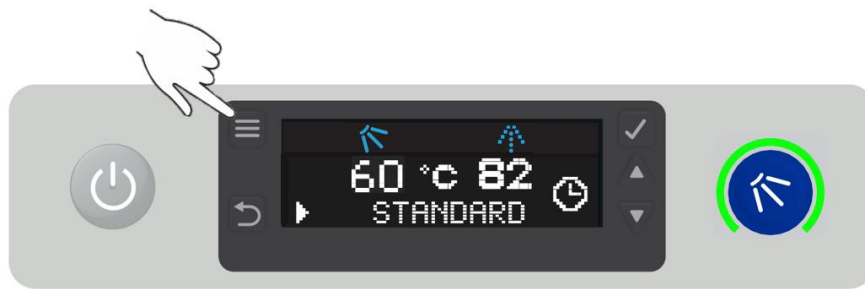

Press Menu button (1) to enter setting Mode.

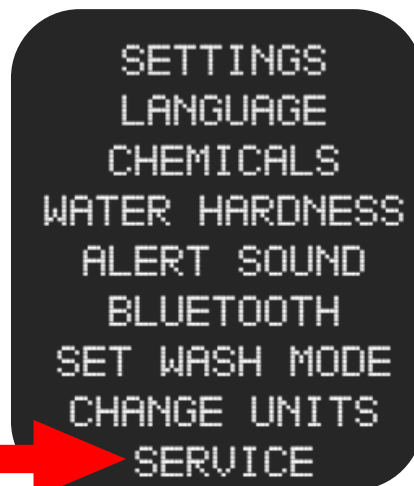
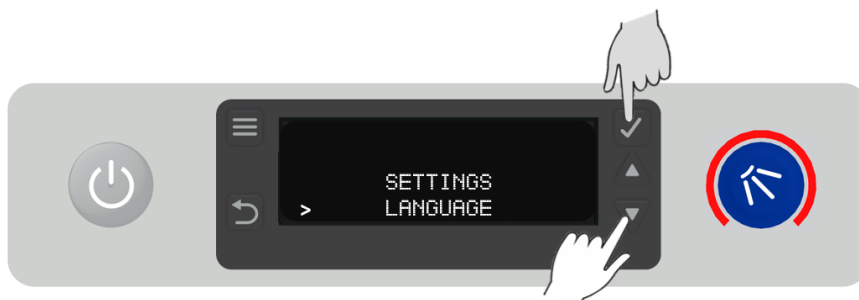

Pressing DOWN (5) button, scroll to SERVICE Options and press SELECT button (2). LED indicator (3) is illuminates to red to notify warewasher in setting mode.

Please note all other options are covered in the **"User Manual"** which is available to download via Classeq's Website or APP.



DISPLAY (6) will prompt to confirm if this option is access by the competent person only. Press

SELECT button (2) to confirm. DISPLAY (6) also displays spanner icon  to notify that warewasher is in Service Mode.

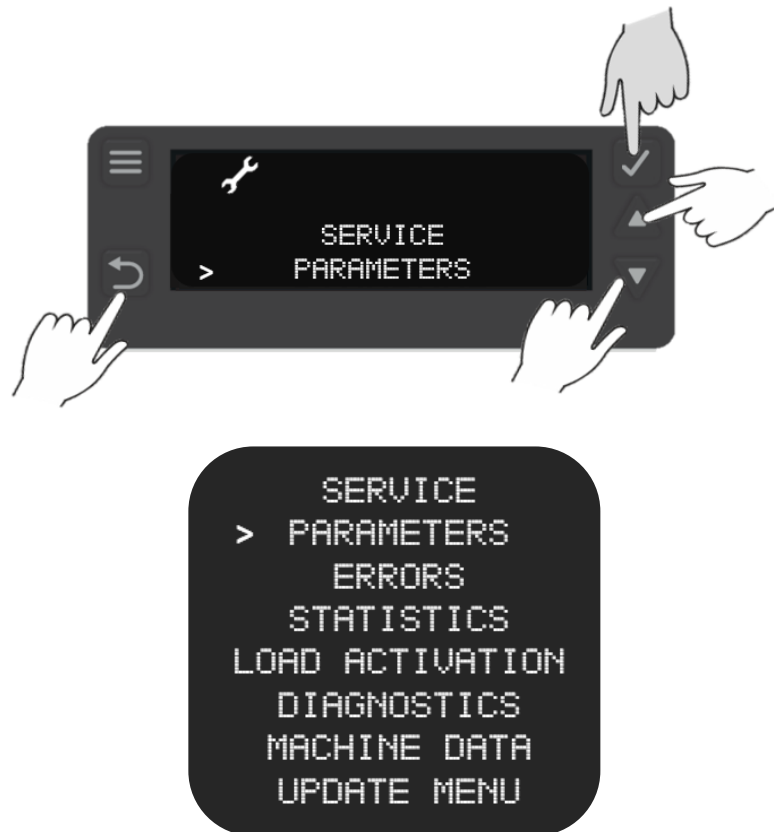

Pressing UP & DOWN (4 & 5) buttons, scroll to SERVICE Lists and press SELECT button (2). Pressing BACK button (7) will take warewasher to Setting Mode and pressing BACK button (7) again will take warewasher to Normal Mode.

7.3.1 Parameters

The parameters menu feeds back the reading that the sensors are receiving at the given time. Below is a list of the program values available. Below is a list of Programmes that can be activated, via the UP and DOWN buttons (4 & 5). To select certain programme press SELECT button (2). To come out of the Parameters menu press BACK button (7).

Press SELECT Button (2) to enter parameters list. Below all the **PARAMETERS** list







P01

Display Wash tank water temperature. This parameter cannot be change and for information purpose only.

Signals are received via Wash tank temperature sensor.

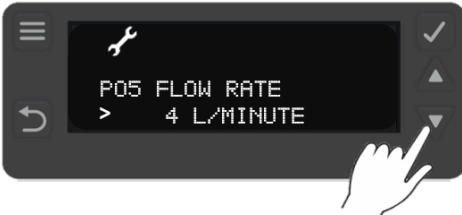

<p>P02 Display Wash tank water level. This parameter cannot be change and for information purpose only.</p> <p>Signals are received via Wash pressure sensor.</p>	
<p>P03 Display Rinse tank water temperature. This parameter cannot be change and for information purpose only.</p> <p>Signals are received via Rinse tank temperature sensor.</p>	
<p>P04 Display Rinse tank water level. This parameter cannot be change and for information purpose only.</p> <p>Signals are received via Rinse pressure sensor.</p>	
<p>P05 Display inlet solenoid valve flow rate. This parameter cannot be change and for information purpose only.</p> <p>This is value corresponds to inlet Solenoid valve and same for all UC range WS and Standard warewasher.</p>	
<p>P06 <i>(Only on WS Warewasher)</i> Display Salt present in the warewasher with internal Water softener.</p> <p>It only displays either Full or Empty. This parameter cannot be change and for information purpose only.</p> <p>Signals are received via Salt float switch connected inside water softener unit.</p> <p><i>Please Note: Standard warewasher will not display this parameter.</i></p>	
<p>P10 This parameter displays either door is open or closed.</p> <p>Signals are received via Door switch mounted on the top panel. This parameter cannot be change and for information purpose only.</p>	

P30

This parameter allows to change the Model type.

Press UP & DOWN buttons (4&5) to select desire Model type and confirm with pressing SELECT button (2).



Caution

Please Note: Refer Rating Label of the warewasher before updating Model. Incorrect model selecting can result in warewasher not working properly.

Any changes made to P30 will not be saved if power to the machine is disrupted before completely exiting service mode.

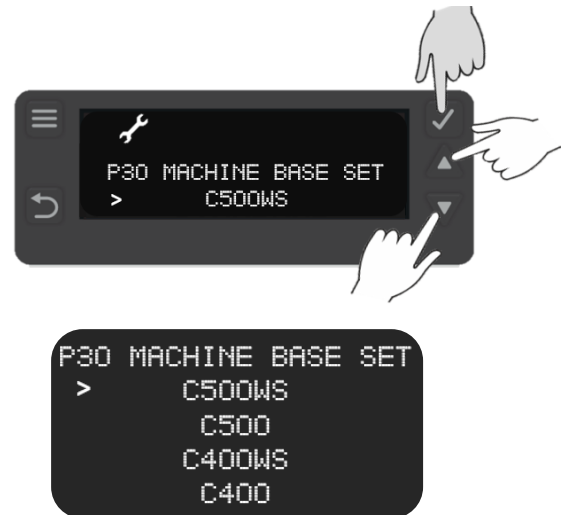
**P40**

This parameter allows to change wash tank water temperature.

Selection range is from 30°C to 75°C.

Default setting or recommended setting is 60°C.

Press UP & DOWN buttons (4&5) to select desire temperature and confirm with pressing SELECT button (2).

**P41**

This parameter allows to change wash tank water **INTERLOCK** temperature.

Selection range is from 30°C to **P40** °C.

(P41 ≤ P40)

Default setting or recommended setting is 0°C.

Press UP & DOWN buttons (4&5) to select desire temperature and confirm with pressing SELECT button (2).

Please Note: Warewasher will not start the cycle till wash tank water interlock temperature is satisfied.

**P50**

This parameter allows to change Rinse tank water temperature.

Selection range is from 55°C to 85°C.

Default setting or recommended setting is 82°C on Dishwasher and 70°C on



Glasswasher.

Press UP & DOWN buttons (4&5) to select desire temperature and confirm with pressing SELECT button (2).

P51

This parameter allows to change rinse tank water **INTERLOCK** temperature.

Selection range is from 55°C to **P50** °C.

(P51 ≤ P50)

Default setting or recommended setting is 55°C.

Press UP & DOWN buttons (4&5) to select desire temperature and confirm with pressing SELECT button (2).

Please Note: Warewasher will not start the rinse cycle and extend the wash cycle till rinse tank water interlock temperature is satisfied.



P60

This parameter allows to change Rinse time during cycle.

Selection range is from 2.0 to 20.0 seconds.

Default setting or recommended setting is 6.0 seconds.

Please Note: 6.0 seconds result in 3 litres of water per cycle, changing this parameter affects water usage of the warewasher.



P72

This parameter allows to change amount of detergent used during the Deep Clean cycle.

Default setting or recommended setting is 7.

Press UP & DOWN buttons (4&5) to select desire multiplier and confirm with pressing SELECT button (2).



P82

This parameter allows the integration of external rinse aid lances to the warewasher.

Signals from the lances prompt the reminder before cycle to refill the rinse aid bottle in event of empty rise aid bottle.

Press UP & DOWN buttons (4&5) to select desire option and confirm with pressing SELECT button (2).

**P83**

This parameter allows the integration of external detergent lances to the warewasher.

Signals from the lances prompt the reminder before cycle to refill the detergent bottle in event of empty detergent bottle.

Press UP & DOWN buttons (4&5) to select desire option and confirm with pressing SELECT button (2).

**P84**

This parameter allows to set reminder in an event of no drain recorded during x number of cycles.

Default settings is disabled.

Press UP & DOWN buttons (4&5) to select desire option and confirm with pressing SELECT button (2).

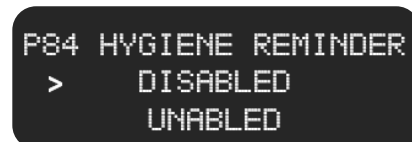
**P85**

This parameter allows to set reminder of regeneration for external water softener fitted warewasher.

Default settings is disabled (OFF). Customize litres can be set from 1 litre to 65500 litres. Selecting OFF will disable this parameter.

Press UP & DOWN buttons (4&5) to select desire option and confirm with pressing SELECT button (2).



P86

This parameter allows to set energy saving Mode when warewasher is inactive for some time. Warewashers standby temperature are set low compared to target temperature.

Press UP & DOWN buttons (4&5) to select desire option and confirm with pressing SELECT button (2).

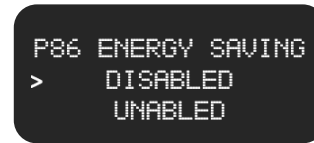
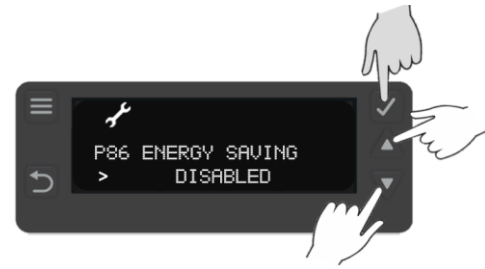
**P87**

This parameter allows to set reminder for service based on number cycles.

Default settings is disabled (OFF). Customize setting range is from can be set from 1 cycle to 65500 cycles. Selecting OFF will disable this parameter.

Press UP & DOWN buttons (4&5) to select desire option and confirm with pressing SELECT button (2).



7.3.2 Errors

The errors menu feeds back the last 38 errors on the machine in order to help identify the fault. Use the UP (4) and DOWN (5) keys to cycle through the list, the list does not roll over and will always start on the most recent error.

Below is a list of error codes and their possible cause. These are given as an aid only; all other possible causes of faults should be investigated before repair is carried out.

Errors E01,03,12,13,18,19 are displayed on the display when the fault is active.

Display	Title	Description	Possible cause
E00	New day	Displays each time the machine is switched on.	
E01	Wash tank pressure sensor	Invalid signal from the wash pressure sensor.	Wash tank pressure sensor faulty or disconnected.
E02	Wash tank temperature sensor	Invalid signal from the wash temperature sensor.	Wash tank temperature sensor faulty.
E03	Rinse tank pressure sensor	Invalid signal from the rinse pressure sensor.	Rinse tank pressure sensor faulty or disconnected.
E04	Rinse tank temperature sensor	Invalid signal from the rinse temperature sensor.	Rinse tank temperature sensor faulty.
E05	Wash water level unchanged during cycle.	Wash tank level not changed after soft start, repeated 3 times before error logged.	Wash pump blocked. Wash arm blocked. Wash pump capacitor failed. Wash pump failed. Board output relay failed.
E06	Rinse water level unchanged during rinse.	Rinse tank level not changed when starting the rinse pump.	Rinse arm blocked. Rinse pump blocked. Rinse pump capacitor failed. Rinse pump failed. Board output relay failed.
E07	Rinse tank temperature not achieved.	Rinse tank has not reached the target temperature within 60 minutes.	Rinse tank over heat thermostat tripped. Rinse tank heating element failed. Rinse tank element contactor failed. Board output relay failed.
E08	Wash tank temperature not achieved.	Wash tank has not reached the target temperature within 60 minutes.	Wash tank over heat thermostat tripped. Wash tank heating element failed. Board output relay failed.
E09	Wash water level unchanged during soft start.	Wash tank level not changed during soft start.	Wash pump blocked. Wash arm blocked. Wash pump capacitor failed. Wash pump failed. Board triac failed.

E10	Salt missing	Only in machines with water softener fitted. Salt level in reservoir is low for 30 seconds.	No salt in reservoir. Salt reed switch failed.
E11	Display communication failure	No signal from the user interface unit.	User interface not correctly connected. User interface failed.
E12	Wash tank fill	Wash tank has not filled within the required number of transfers.	Drain plug not inserted. Machine leaking. Very low water pressure (pressurised machines).
E13	Rinse tank fill timeout	Rinse tank has not filled within 5 minutes.	Water supply not connected or turned on. Very low water pressure. Solenoid valve failed.
E14	Door switch	Door switch has not changed position for the past 20 cycles	Door switch failed.
E16	Wash tank overflow	Wash tank has reached the flood risk level.	Site drain blocked. Machine waste hose blocked or kinked. Solenoid failed open. Drain pump failed.
E17	Filter mesh blocked	Water level in wash tank has been reduced to below minimum required level during a wash cycle.	Wash arms blocked. Wash pump blocked. Wash filters blocked. Container in wash tank collecting water.
E18	Rinse tank temperature exceeded	Rinse tank temperature has exceeded the safety limit.	Rinse tank temperature sensor disconnected. Rinse element relay fused. Main board relay fused. Rinse element wired incorrectly.
E19	Wash tank temperature exceeded	Wash tank temperature has exceeded the safety limit.	Wash tank temperature sensor disconnected. Main board relay fused. Wash element wired incorrectly.
E20	Power interruption	Power to machine has been interrupted.	Machine isolated from power supply. Power failure.
E21	EEPROM Error	EEPROM failed	Main board failed
E22	Invalid machine type	Incorrect machine type set	Machine type 0. Main board has not been configured.
E28	Service Reminder Call Service provider	Warewasher reached the value set on parameter P87 .	Call Service provider to update P87 value.

Items in **BOLD** will cause the machine to enter error mode; this will turn off the machine and illuminate the LED indicator **(3)** red.

E12 – Number of cycles will differ depending on machine.

7.3.3 Statistics

The statistics menu provides data on various aspects of the machine. Below is a list of the statistics that can be viewed.



Display	Description	Units
S00	Total number of completed wash cycles	
S01	Total run time (Power connected)	Hours
S02	Total active time (Machine ON)	Hours
S03	Total water usage	Litres
S04	Drain pump failures	
S20	Total number of regenerations	
S21	Total number of cycles without salt	
S22	Total number of Deep Clean Cycle	

S20 and S21 are only active in machines with integral water softener fitted.

7.3.4 Load Activation

The loads menu allows activation of specific loads within the machine in order to test their function. Some loads have safety criteria that need to be achieved before the load can be activated, if the component does not activate when the load is activated first check the continuity or resistance of the component through the harness.



Below is a list of loads that can be activated, via the UP and DOWN buttons (4 & 5), and their required criteria. Each of the loads has a safety timeout applied to reduce the risk of wear on the components.

Display	Description	Value	Safety criteria
L00	Wash pump	0 = Off 1 = On	Wash water level above minimum level and door closed.
L01	Wash pump + soft start	0 = Off 1 = On	Wash water level above minimum level and door closed.
L02	Wash tank heat element	0 = Off 1 = On	Wash water level above minimum level.
L03	Detergent pump	0 = Off 1 = On	
L04	Rinse pump	0 = Off 1 = On	
L05	Rinse aid pump	0 = Off 1 = On	
L06	Wash tank heat element - Spare	0 = Off 1 = On	Wash water level above minimum level.
L07	Rinse tank heat element	0 = Off 1 = On	Rinse water level above minimum level and door closed.
L08	Inlet solenoid valve	0 = Off 1 = On	
L09	Drain pump	0 = Off 1 = On	
L11	WS Salt valve	0 = Off 1 = On	
L12	WS Waste valve	0 = Off 1 = On	
L13	WS Waste valve + inlet valve	0 = Off 1 = On	

Please Note: L11 and L12 will display if an integral water softener is fitted.

7.3.5 Diagnostics

This Service module allows to run the diagnostics tool on the warewasher. In an event of first Error recorded Diagnostic progress stops and Error is displayed. Re-run the diagnostic tool once Error has been resolved. For more information on Error please refer section (► 7.3.2)

<p>Press SELECT button (2) to activate diagnostics tool.</p>	
<p>Display shows the progress bar.</p>	
<p><u>In an Event of NO Errors</u></p>	
<p><u>In an Event of Error</u> (Image is example only)</p>	

7.3.6 Machine Data

Machine data provides warewasher information only. Information cannot be change.

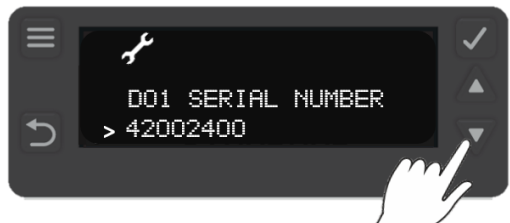
<p>Press SELECT button (2) to view the machine information.</p>	
<p>Press the DOWN button (5) to view more information after serial number. (Image is example only)</p>	

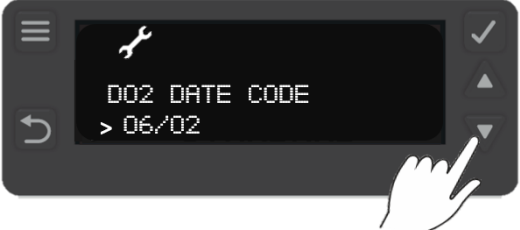
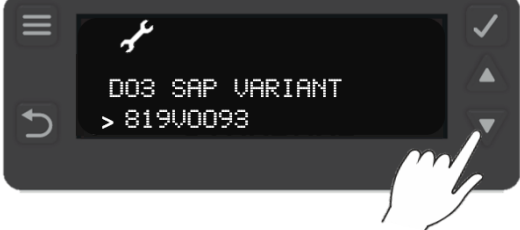
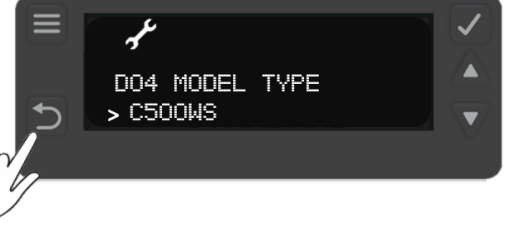
<p>Press the DOWN button (5) to view more information. (Image is example only)</p>	
<p>Press the DOWN button (5) to view more information. (Image is example only)</p>	
<p>Press the BACK button (7) to exit Machine Data Menu. (Image is example only)</p>	

7.3.7 Update Menu

Update Menu provide information on the Software version.

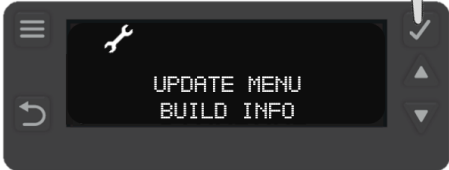
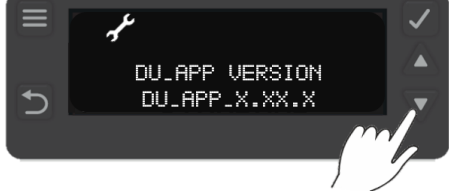
<p>Press SELECT button (2) to enter Update Menu.</p>	
<p>Press SELECT button (2) to view the software version information.</p>	
<p>Press the DOWN button (5) to view more information. DU – Display Unit CWS - Main Board.</p>	
<p>Press the BACK button (7) to exit Update Menu.</p>	

8. Control unit



DANGER!

Unless the machine has been isolated from the supply there will always be potential for mains voltage to any components in the machine.



Caution

Repairs to the machine should only be done with the mains supply isolated.

8.1 Inputs and outputs

8.1.1 Main board

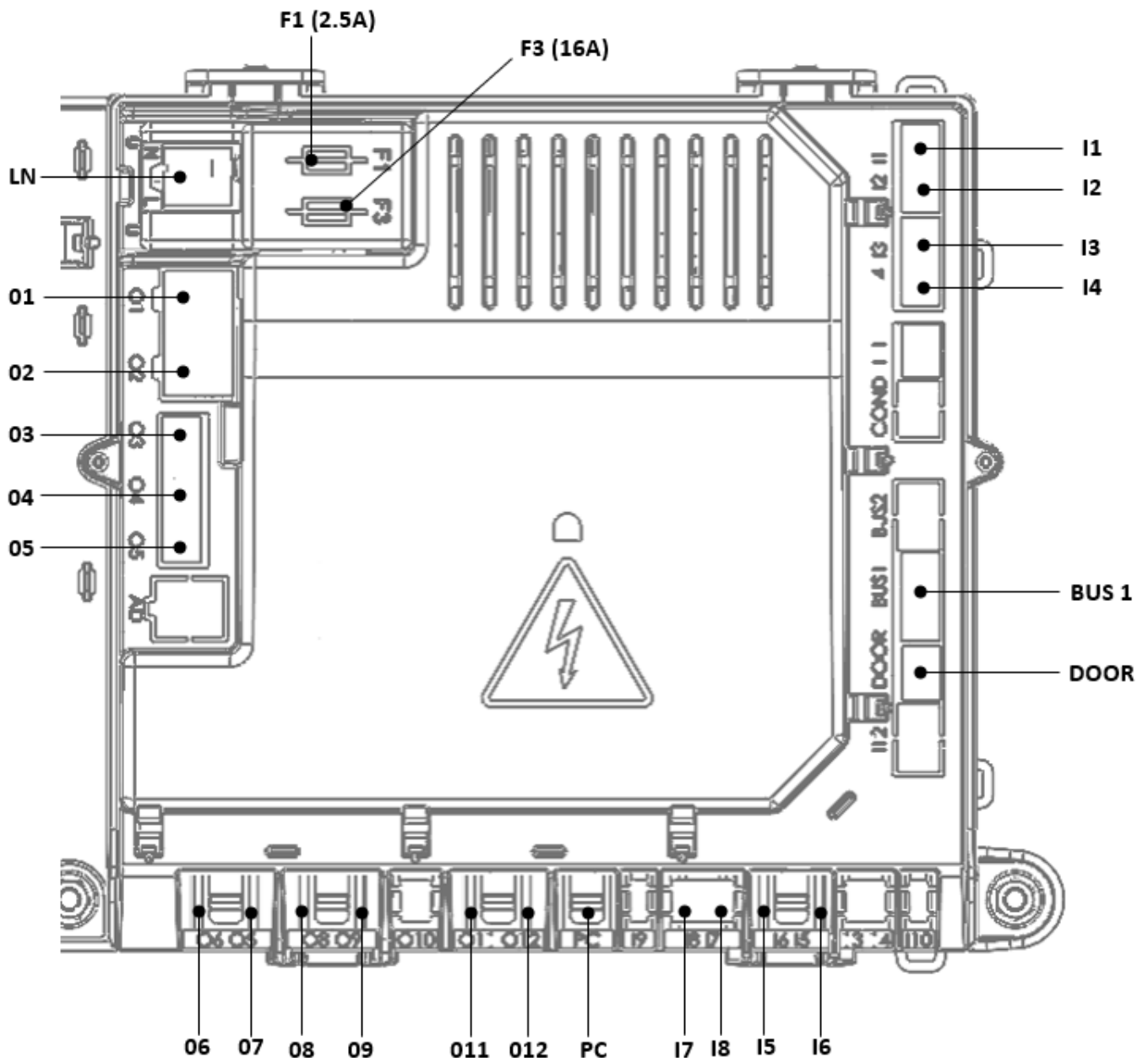



Inputs	
Label	Device
I1	Wash temperature sensor
I2	Wash pressure sensor
I3	Rinse temperature sensor
I4	Rinse pressure sensor
I5	Water softener float switch
I6	Not used
I7	Detergent Lance (Optional)
I8	Rinse Aid Lance (Optional)
Bus	User interface
Door	Door switch
PC	Production test port
LN	Mains power from terminal block
F1	2.5A Fuse [O3, O5, O6, O7, O8, O9, O10, O11 & O12]
F3	16A Fuse [O1, O2 & O4]

Outputs	
Label	Load
O1	Wash pump
O2	Wash element
O3	Detergent pump
O4	Rinse booster pump
O5	Rinse Aid pump
O6	<i>Not used</i>
O7	Rinse contactor
O8	Inlet solenoid valve
O9	Drain pump
O10	<i>Not used</i>
O11	WS Salt Valve
O12	WS Waste Valve

8.2 Board setup

In the event of changing a control board the new board will need to be configured to the machine. The warewasher automatically detect new board and ask to perform initial set-up. Warewasher is not accessible until this set up is completed.

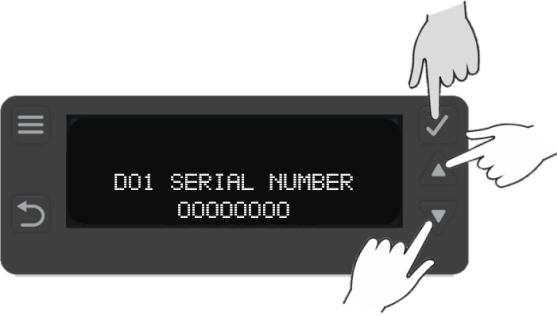
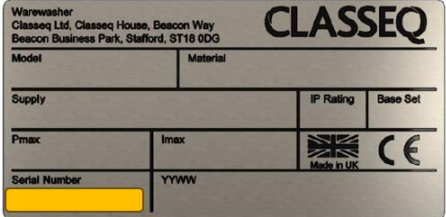
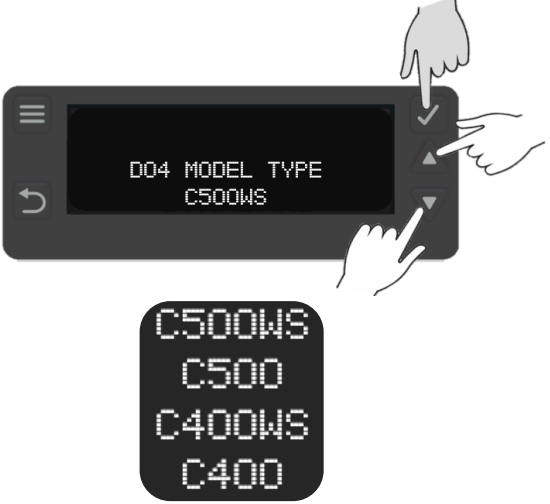
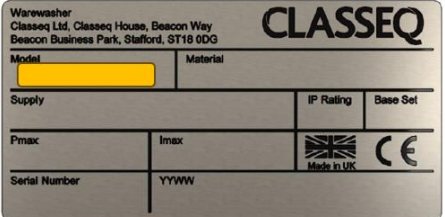
Step	Instruction	
1		<p>Switch the warewasher ON by pressing ON/OFF Button</p>
2		<p>Press SELECT button (2) to start the set up.</p>
3		<p>Press UP & DOWN buttons (4&5) to select numbers which matches to serial number on the Rating Label (Silver Label) and confirm with pressing SELECT button (2).</p> 
4		<p>Press UP & DOWN buttons (4&5) to select from list the model which matches to model on the Rating Label (Silver Label) and confirm with pressing SELECT button (2).</p> 
5	<p>Setup now is completed.</p>	



Caution

Refer the rating label to find correct Model type and Serial number.

9. Cable Repair Kits

Available Cable Kits list

Detailed below are the spares cable kits available for the machine:

Item	Description	Part number
1	KIT MACRO-MODULE PLUG SIZE 2,5 6-POLE	30002484
2	KIT MACRO-MODULE PLUG SIZE 2,5 5-POLE	30002483
3	KIT MACRO-MODULE PLUG SIZE 2,5 4-POLE	30002482
4	KIT MACRO-MODULE PLUG SIZE 2,5 3-POLE	30000198
5	KIT MACRO-MODULE PLUG SIZE 2,5 2-POLE	30000197
6	Module Plug (Size 5,0 / 4Pole) Type A	30014137
7	Module Plug (Size 5,0 / 4Pole) Type B	30014138
8	Module Plug (Size 5,0 / 6Pole)	30014140
9	MACRO-MODULE PLUG5, 5-POLE	3112091
10	Marco Module Plug5, 5Pole	30002002
11	6.0kW Element Wire Kit	30013685

10. Tool list

The below list of tools will allow access to all components within the machine:

Tool group	Description
Spanner/nut runner/ratchet	5.5mm
	7mm
	8mm
	13mm
Posi screwdriver	No. 2
	No. 3
Electrical testing	Ammeter (A)
	Capacitance meter (μF)
	Resistance meter (Ω)
	Continuity (\rightarrow)

12. Machine Rating

These diagrams are schematic references.

6.0 kW Configuration			
	Machine rating (Volts / Phase / Amps)		Cable type
	220-240V / 1N~/13A		H07RN-f 3G 1.5
	Temp. rating	Length of cable	Conforms to
80°C min.	3m	IEC 60335-2-58 & IEC 60227 types 56 & 57	
	Machine rating (Volts / Phase / Amps)		Cable type
	220-240V / 1N~/20A		H07RN-f 3G 4.0
	Temp. rating	Length of cable	Conforms to
80°C min.	3m	IEC 60335-2-58 & IEC 60227 types 56 & 57	
	Machine rating (Volts / Phase / Amps)		Cable type
	220-240V / 1N~/30A		H07RN-f 3G 4.0
	Temp. rating	Length of cable	Conforms to
80°C min.	3m	IEC 60335-2-58 & IEC 60227 types 56 & 57	

		Machine rating (Volts / Phase / Amps)	Cable type
		380-415V / 3N~/11A	H07RN-f 5G 2.5
Temp. rating	Length of cable	Conforms to	
80°C min.	3m	IEC 60335-2-58 & IEC 60227 types 56 & 57	

Document number: 90001723

Revision: DEV-02

Date: 23/10/2023

Language: English