

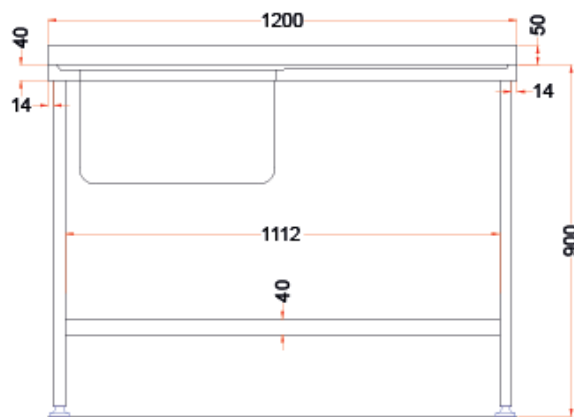

STAINLESS STEEL SINK - DR362 FLATPACK

DIMENSIONS

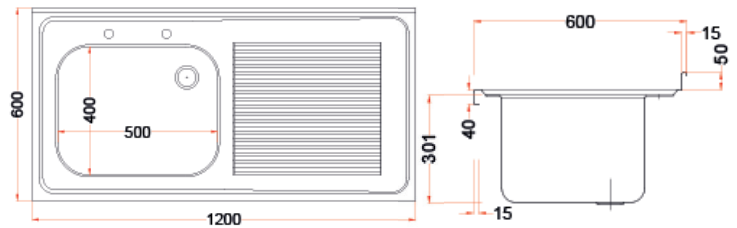

This 1200mm wide stainless steel sink from British specialists Holmes features a left side bowl and right side drainer, and a hard wearing 304 stainless steel construction. Easy to assemble and keep clean, the commercial grade steel is used in kitchens for its ability to resist corrosion and ensure the highest standards of kitchen hygienic. The sink easily allows you to create practical washing areas and also features a strong undershelf providing extra storage for tools, equipment or extra supplies.

TECHNICAL DATA

Unpacked height (mm)	900 + 50 upstand
Unpacked width (mm)	1200
Unpacked depth (mm)	600
Weight (kg)	13
Material top	SAE grade 304; EN 1.4301, X5CrNi18-10
Material sub-top	SAE grade 430; EN 1.4016, X6Cr17
Surface finish	Satin
Type of Mounting	Floor
Feet	Adjustable

Property of Holmes