



OD8007/N - Opus 800
Dual Fuel [Natural Gas]
Free-standing Oven
Range - 6 Burners - W
900 mm - 45.0 kW

This powerful Opus 800 dual fuel oven is built to deliver high volumes of top quality food and will withstand the rigours of even the busiest kitchen.

- ✓ Powerful 7.5kW dual concentric Burners for focused heat distribution from a fast boil to a low simmer
- ✓ Individual heavy-duty single cast iron supports, built to withstand the rigours of the busiest kitchen
- ✓ Low flue to allow use of the complete hob top
- ✓ Powerful 6kW twin fan assisted oven for even cooking results
- ✓ Large 6 x GN1/1 capacity oven enabling six different foods to be cooked simultaneously
- ✓ Dual Fuel Oven Ranges

Specifications

Summary

Range Name	Opus 800
Power Type	Dual Fuel
Gas Type	Natural Gas
Unit Type	Free-standing
Available in UK Only	No
UK Warranty	2 Years Parts and Labour Warranty
Export Warranty	Contact your local dealer
GTIN Code	5056105102328

Power and Performance

BTU per Hour	153,546
Gastronorm Capacity	6 x GN1/1
Total Power kW	45.0
Temperature Range °C	120 - 280
IP Rating	IP24
Temperature Control	Mechanical
Rating per Hob kW	7.5
Oven Rating kW	6.0

Key Specifications

Number of Shelves included	3
Number of Shelf Positions	5
Number of Hobs	6
Shape of Hob	Square

Weights and Dimensions

Unit Height (External) mm	912
Unit Width (External) mm	900
Unit Depth (External) mm	800
Height (Internal) mm	410
Width (Internal) mm	825
Depth (Internal) mm	530
Shelf Dimensions Width mm	770
Shelf Dimensions Depth mm	530
Hob Dimensions mm	300 x 300
Net Weight Kg	186

Supply Connections

Requires Installation	Yes
Requires Electrical Supply	Yes
UK 3 Pin Plug	No
Requires Hardwiring	Yes
Electrical Supply Rating Watts	6,060
Single Phase Amps	26.0
Single Phase Voltage	230
Three Phase Amps	L1=9.0 ; L2=8.7 ; L3=8.7
Three Phase Voltage	400
Gas Connection BSP	3/4"
Gas Consumption at full rate Natural m ³ per Hour	4.06
Gas Pressure Natural mbar	20.0
Total heat input at full rate Natural kW	45.0
Total heat input at full rate Natural BTU per hour	153,546

Shipping

Packed Weight Kg	201
Packed Height cm	107
Packed Width cm	100
Packed Depth cm	85

Available Accessories

CH01	CATERFLEX HOSE 1/2" 1 METRE
CH02	CATERFLEX HOSE 1/2" 1.5 METRE
LK06	OPUS 800 LEG KIT
OA8985	SPLASHBACK/SHELF - OD8007

Technical Picture

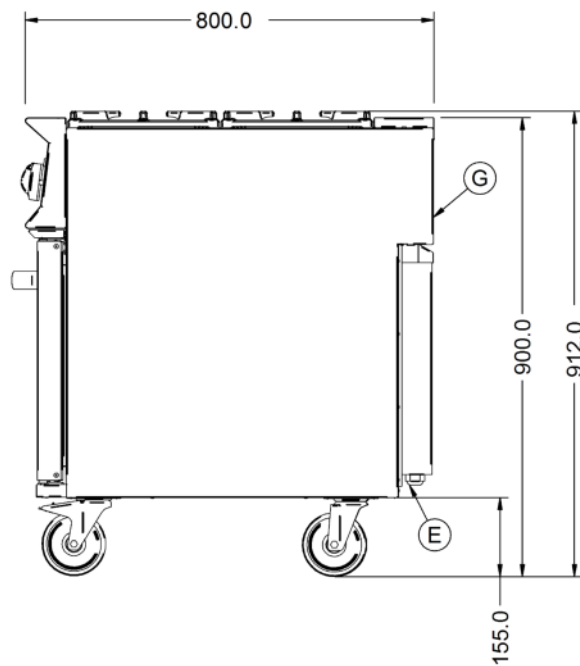
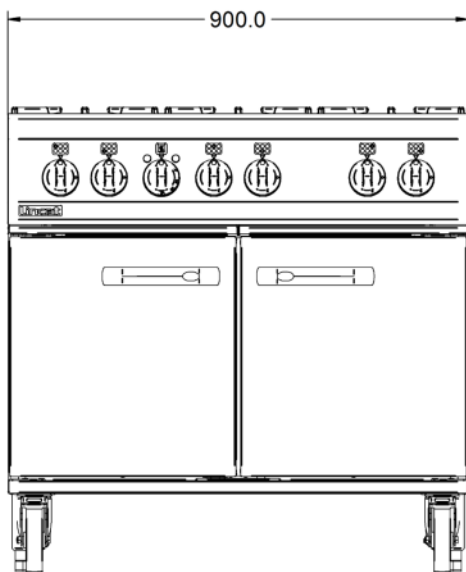
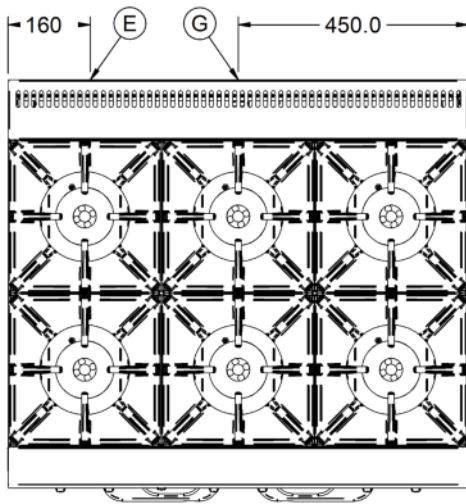

Lincat Limited

Whisby Road,
Lincoln, LN6 3QZ,
United Kingdom

Company No: 2175448

A member company of



Customer Care

Tel: +44 1522 875500
Email: care@lincat.co.uk

Export Customers

Tel: +44 1522 503250
Email: export@lincat.co.uk

Opening Hours

Monday – Friday:
8.30am – 5pm