

Conservators

IKG275

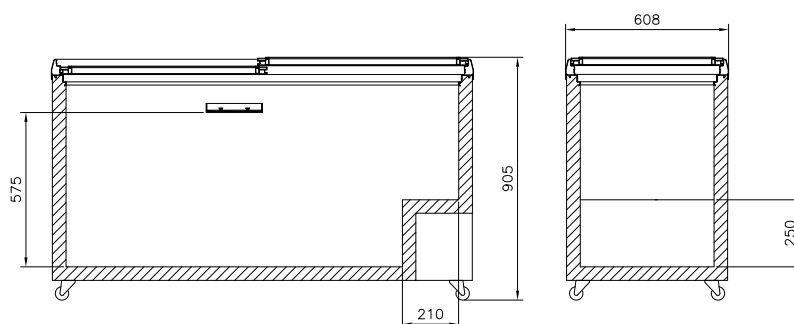

IKG405



FEATURES

White laminated exterior

Aluminium interior

Sliding glass lid

Castors as standard

Skin condenser

TECHNICAL SPECIFICATIONS

Controller: Manual thermostat

Cooling: Static

Defrost: Manual

Refrigerant: R600a

Climate Class: 4

Temperature Range: -18°C ~ -24°C

Power Supply: 13amp

MODEL	GROSS CAPACITY	BASKETS SUPPLIED	MAX. BASKETS	EXT. DIMENSIONS (H x W x D mm)	POWER CONSUMPTION	DECIBELS	WEIGHT (kg)	RRP
IKG205	194L	1	2	905 x 720 x 600	180W	42dBA	46	
IKG275	265L	2	3	905 x 920 x 600	260W	43dBA	52	
IKG405	386L	3	5	905 x 1260 x 600	300W	44dBA	64	
IKG505	492L	3	6	905 x 1560 x 600	320W	44dBA	74	

