

**ecomax**<sup>TM</sup>  
by **HOBART**

# GLASS AND DISHWASHER



made in germany

**LOW PRICE**  
**HIGH PERFORMANCE**



# OVERVIEW OF OUR MODELS

**ecomax**<sup>™</sup>  
by **HOBART**

The entry-level models for those who search for a low-cost dishwasher for commercial use. Ideal for start-ups and companies with irregular washing frequency, who invest in a dishwasher for the first time. **ecomax** meets all requirements for hygienic wash results.

**Model G404**  
Compact glasswasher



**Model F504**  
Undercounter dishwasher



**ecomax**  
by **HOBART** **plus**

For budget-oriented operators who seek a plus for comfort and equipment. **ecomax plus** combines all the features of an **ecomax** dishwasher and offers a plus for wash power, energy efficiency, noise reduction and ease of use.

**Model G415**  
Compact glasswasher



**Model F515**  
Undercounter dishwasher



**Model F515L**  
Undercounter dishwasher  
with deeper wash chamber



**plus**

**LOW PRICE**  
**HIGH PERFORMANCE**



# OVERVIEW OF OUR MODELS

made in germany

**ecomax**<sup>™</sup>  
by **HOBART**

**Model H604**  
Hood-type dishwasher



**ecomax**<sup>™</sup> **plus**  
by **HOBART**

**Model H615**  
Hood-type dishwasher



**plus**

## ECOMAX G404 COMPACT GLASSWASHER

*The fast and reliable glasswasher in compact design. Perfect for start-ups, small bars or restaurants.*



### FEATURES

- Single-button control with digital temperature indication, 3 programmes and further special cycles
- Rotating wash and rinse arms for an even water distribution
- Indented nozzles prevent blocking
- Integrated counter for cycles and water consumption, e.g. for control of water treatment system
- Double-walled housing and door
- Deep drawn rack track for easy cleaning
- USB connection for easier service access
- Incl. connection cable, supply and drain hose for immediate operation
- Thermostop function for guaranteed temperatures
- Hygiene programme for hygienic cleanliness
- Refill signal monitors fill level of external chemical containers with optional suction lances





## ECOMAX PLUS G415 COMPACT GLASSWASHER

*The compact glasswasher  
for hotels, bars and restaurants,  
that are washing more than a  
hundred glasses a day.*

### plusFEATURES

+++ additional to ecomax +++

- + Best cleaning results thanks to additional cutlery cycle
- + Deep-drawn wash tank for easy cleaning
- + Double-walled, insulated housing and thermally insulated front door for reduction of noise and energy losses
- + Better energy efficiency saves operating costs
- + Tank strainer, coarse filter and pump suction casing secure safe operation
- + Door damping control for long life operation
- + Fully equipped with rinse pressure pump, detergent and rinse aid dispenser and drain pump





## ECOMAX F504 DISHWASHER

*With a high capacity of up to 60 racks per hour, this dishwasher is a reliable partner for club houses, bistros, and fast-food restaurants. The practical floor unit fits under every work counter.*

### FEATURES

- Single-button control with digital temperature indication, 3 programmes and further special cycles
- Rotating wash and rinse arms for an even water distribution
- Indented nozzles prevent blocking
- Integrated counter for cycles and water consumption, e.g. for control of water treatment system
- Deep drawn rack track for easy cleaning
- Double-walled housing and door
- Refill signal monitors fill level of external chemical containers with optional suction lances
- USB connection for easier service access
- Incl. connection cable, supply and drain hose for immediate operation
- Thermostop function for guaranteed temperatures
- Hygiene programme for hygienic cleanliness
- Tank strainer reduces soiling of the tank water
- Rinse pressure pump for optimum flow pressure
- Optional cabinet base for ergonomic operation





## ECOMAX PLUS F515 / F515L DISHWASHER

*Due to the high wash power and the robust filter systems, it is the quiet and resource-saving solution for your busy workday life.*

### plusFEATURES

+++ additional to ecomax +++

- + Best cleaning results thanks to additional cutlery and glasswashing cycle
- + Deep-drawn wash tank for easy cleaning
- + Double-walled, insulated housing and thermally insulated front door for reduction of noise and energy losses
- + Better energy efficiency saves operating costs
- + Coarse filter secures safe operation
- + Door damping control for long life operation
- + Fully equipped with rinse pressure pump, detergent and rinse aid dispenser and drain pump



### F515L FEATURE

- + Extra deep wash chamber suitable to wash trays of 600 x 400 mm or EN containers

### F515 FEATURE

- + Bottle washing programme for the hygienic cleaning of bottles with optional bottle washing system, consisting of spray attachment, wire attachment and bottle rack



## ECOMAX H604 HOOD-TYPE DISHWASHER

*The ecomax hood-type dishwasher is, combined with tables, a powerful partner for the catering and hotel sector.*

### FEATURES

- The 4-sided closed hood keeps energy and humidity in the system and saves up to 3 kW energy
- Electronic control with digital temperature indication and 3 programmes for easy operation
- Deep-drawn wash tank for easy cleaning
- Rotating wash and rinse arms for an even water distribution
- Refill signal monitors fill level of external chemical containers with optional suction lances
- Intended nozzles prevent blocking
- Incl. connection cable, supply and drain hose for immediate operation
- Thermostop function for guaranteed temperatures





## ECOMAX H615 HOOD-TYPE DISHWASHER

*The hood-type dishwasher for ergonomic and efficient work processes in the kitchen, thanks to the single-button control on top and the all-around handle.*

### plusFEATURES

+++ additional to ecomax +++

- + Single-button control on top of the hood with digital temperature indication, 3 programmes and further special cycles
- + All-around handle for an ergonomic hood lift
- + Reduced rinse water consumption
- + Hygiene programme for hygienic cleanliness

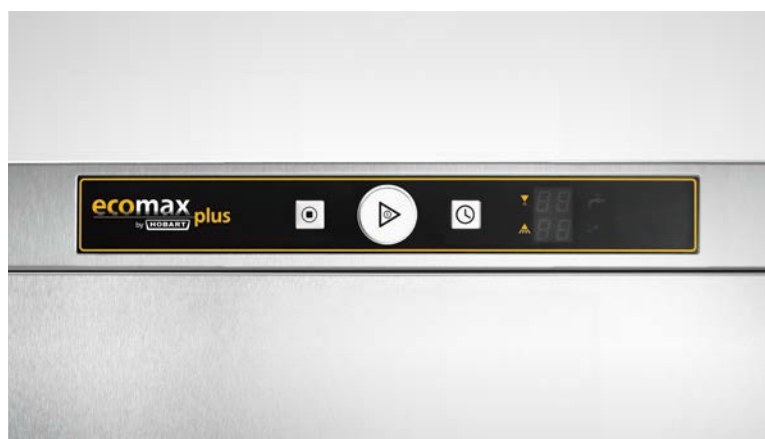



# HYDROLINE WATER TREATMENT



*Always the exactly right water quality for your application – whether your focus is on protecting your machine efficiently against limescale, or on ensuring that your wine glasses are free of stains after washing.*

## External single-chamber softener SE-H

Protects heating rods against limescale and reduces detergent consumption. Quantity-controlled automatic regeneration.

## External double-chamber softener SD-H

Protects heating rods against limescale and reduces detergent consumption. Regeneration takes place parallel to the cleaning process.

## Partial demineralisation cartridge STAR PD

Residue-free removal of hardness components from the water.

## Full demineralisation cartridge STAR EXTRA FD

Removes all minerals from the water. For brilliant wash results for glasses and cutlery.

## Reverse osmosis RO-S

Removes all minerals and particles from the water. For brilliant wash results for glasses and cutlery.

# HYLINE HYGIENE RANGE DETERGENT / RINSE AID

*Highly-concentrated liquid detergents for use in commercial dishwashers. Extremely effective and therefore economic in use. Tailor-made for **ecomax** and **ecomax plus** dishwashers.*



*Highly-concentrated rinse aid for use in commercial dishwashers. Makes glasses and cutlery shining and provides a spotlessly clean wash result.*



# DRAWINGS

## UNDERCOUNTER GLASS AND DISHWASHERS

**Glasswasher G404**

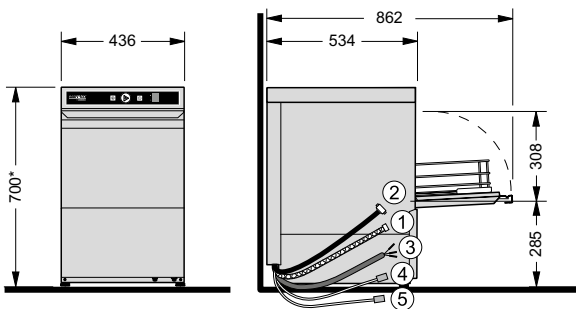

\* + 40 mm adjustable feet

**Glasswasher G415**

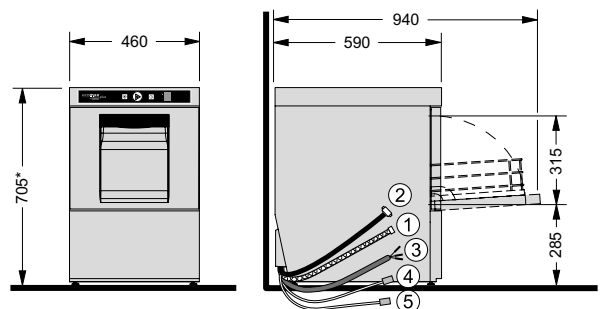

\* + 40 mm adjustable feet

**Undercounter dishwasher F504**

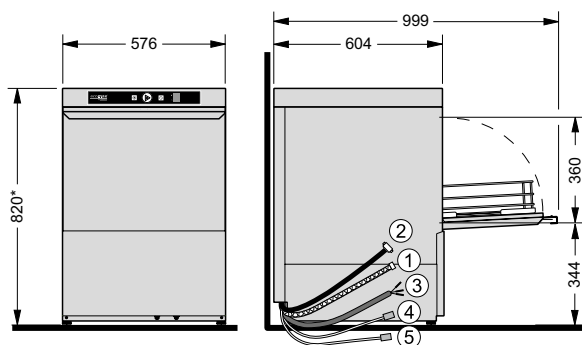

\* + 40 mm adjustable feet

**Undercounter dishwasher F515**

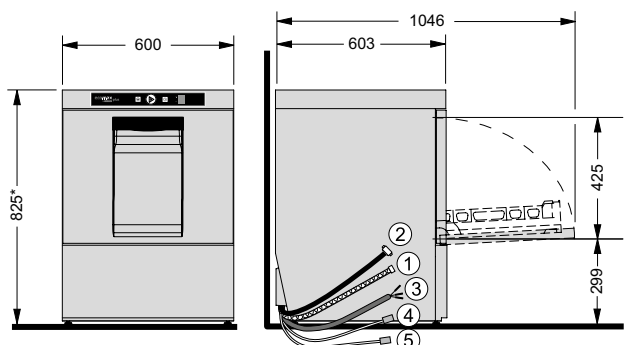

\* + 40 mm adjustable feet

**Undercounter dishwasher F515L**

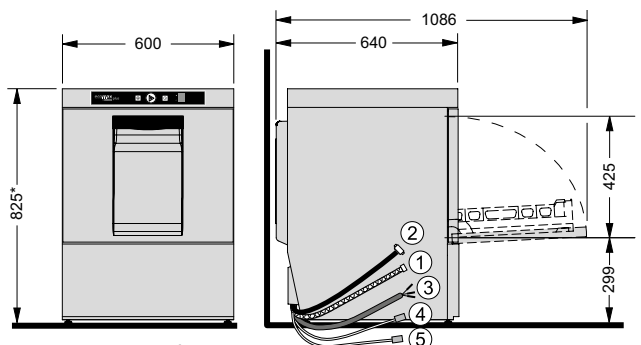

\* + 40 mm adjustable feet

- ① Drain hose
- ② Supply hose
- ③ Connection cable
- ④ Liquid detergent <sup>a)</sup>
- ⑤ Rinse aid <sup>a)</sup>

<sup>a)</sup> for machines with external containers

**plus**

# DRAWINGS

## HOOD-TYPE AND UTENSIL WASHERS

Hood-type dishwasher H604

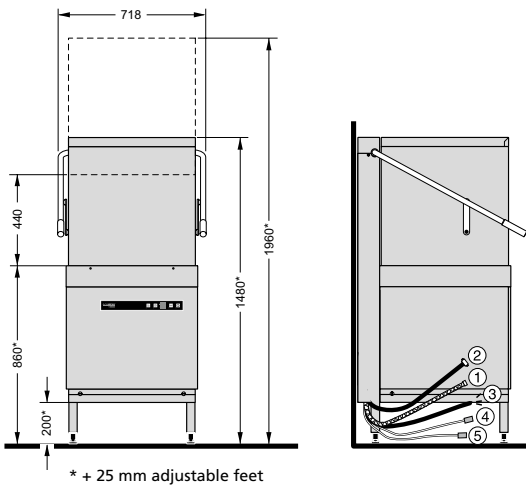

Hood-type dishwasher H615

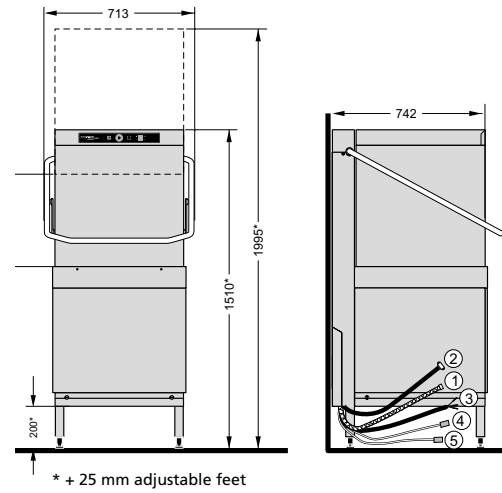

- ① Drain hose
- ② Supply hose
- ③ Connection cable
- ④ Liquid detergent <sup>a)</sup>
- ⑤ Rinse aid <sup>a)</sup>

<sup>a)</sup> for machines with external containers

plus

# FEATURES

MODELS	GLASSWASHER						UNDERCOUNTER DISHWASHER							
	G404 -10	G404 S-10	G404 -12	G404 S-12	plus G415 -11 G415 S-10		F504 -10	F504 S-10	F504 -12	F504 S-12	plus F515 -11 F515 S-11 F515L -11 F515L S-11			
Integrated water softener*	-	●	-	●	-	●	-	●	-	●	-	●	-	●
Double-walled housing – insulated	-	-	-	-	●	●	-	-	-	-	●	●	●	●
Double-walled housing	●	●	●	●	-	-	●	●	●	●	-	-	-	-
Deep-drawn wash tank	-	-	-	-	●	●	-	-	-	-	●	●	●	●
Door damping control	-	-	-	-	●	●	-	-	-	-	●	●	●	●
Tank strainer	-	-	-	-	●	●	●	●	●	●	●	●	●	●
Drain pump	○	○	●	●	●	●	○	○	●	●	●	●	●	●
Rinse pressure pump**	-	●	-	●	●	●	●	●	●	●	●	●	●	●
Rinse aid dispenser	●	●	●	●	●	●	●	●	●	●	●	●	●	●
Detergent dispenser	○	○	●	●	●	●	○	○	●	●	●	●	●	●
Chemical suction lances	○***	○***	○***	○***	○	○	○***	○***	○***	○***	○	○	○	○
Bottle washing system	-	-	-	-	-	-	-	-	-	-	○	○	-	-
Deeper wash chamber	-	-	-	-	-	-	-	-	-	-	-	-	●	●
Base cabinet (435 mm high) with removable door	-	-	-	-	-	-	○	○	○	○	○	○	○	○
Glass rack (4 sloped rows) 00-139321-057	●	●	●	●	-	-	-	-	-	-	-	-	-	-
Glass rack (4 sloped rows) 371450-84	-	-	-	-	●	●	-	-	-	-	-	-	-	-
Plate rack P-18-12	-	-	-	-	-	-	●	●	●	●	●	●	●	●
Cutlery box CB1	○	○	○	○	○	○	●	●	●	●	○	○	○	○
Cutlery rack with 4 boxes 01-246175-1	-	-	-	-	-	-	○	○	○	○	●	●	●	●
Universal flat rack B-00-07	-	-	-	-	-	-	○	○	○	○	●	●	●	●

\* For machine protection the water hardness should not exceed 3°dH, if higher we recommend using an integrated water softener or an external water treatment system.

\*\* Necessary flow pressure without rinse pressure pump: 2 - 6 bar. Flow pressure with integrated rinse pressure pump: 0.8 - 6 bar.

\*\*\* Available from March 2025

● Inclusive      ○ Optional



# FEATURES

made in germany

MODELS	HOOD-TYPE DISHWASHER			plus	
	H604 -10	H604 -12	H604 S-12	H615 -10	H615 S-10
Integrated water softener*	–	–	●	–	●
Double-walled housing – insulated	–	–	–	–	–
Deep-drawn wash tank	●	●	●	●	●
Door damping control	–	–	–	–	–
Tank strainer	●	●	●	●	●
Drain pump	○	●	●	●	●
Rinse pressure pump**	–	●	●	●	●
Rinse aid dispenser	●	●	●	●	●
Detergent dispenser	○	●	●	●	●
Chemical suction lances	○	○	○	○	○
HOBART tabling programme	○	○	○	○	○
Plate rack P-18-12	●	●	●	●	●
Cutlery box CB1	●	●	●	○	○
Cutlery rack with 4 boxes 01-246175-1	○	○	○	○	○
Cutlery rack with 8 boxes CB8	○	○	○	●	●
Universal flat rack 01-510508-1	–	–	–	–	–
Universal flat rack B-00-07	○	○	○	●	●

\* For machine protection the water hardness should not exceed 3°dH, if higher we recommend using an integrated water softener or an external water treatment system.

\*\* Necessary flow pressure without rinse pressure pump: 2 - 6 bar. Flow pressure with integrated rinse pressure pump: 0.8 - 6 bar.

● Inclusive      ○ Optional

TECHNICAL SPECIFICATIONS



# TECHNICAL SPECIFICATIONS

made in germany

MODELS	ecomax™ by HOBART			ecomax plus by HOBART			
	G404	F504	H604	G415	F515	F515L	H615
Cycle times*	60/120/180 s	60/120/180 s	75/150/180 s	60/120/180 s	60/120/180 s	60/120/180 s	60/90/180 s
Rack capacity	60 /h	60 /h	48 /h	60 /h	60 /h	60 /h	60 /h
Tank capacity	10 l	25 l	21 l	8 l	10.6 l	10.6 l	23 l
Water consumption	1.8 l/rack	2.0 l/rack	2.3 l/rack	1.8 l/rack	2.0 l/rack	2.0 l/rack	2.2 l/rack
Wash pump	0.18 kW	0.34 kW	0.4 kW	0.4 kW	0.5 kW	0.5 kW	0.7 kW
Tank heating	1.8 kW	1.8 kW	2.5 kW	0.8 kW	0.8 kW	0.8 kW	2.5 kW
<b>BOOSTER LOADING</b>							
Standard	1.8 kW (230 V)	5.5 kW (400 V)	6.2 kW (400 V)	2.8 kW (230 V)	6.2 kW (400 V)	6.2 kW (400 V)	6.2 kW (400 V)
Alternative	5.5 kW (400 V)	1.8 kW (230 V)	–	4.1 kW (400 V)	2.0 kW (230 V)	2.0 kW (230 V)	4.1 kW (230 V)
<b>TOTAL CONNECTED LOAD</b>							
Standard	2.1 kW (230 V)	5.9 kW (400 V)	6.6 kW (400 V)	3.2 kW (230 V)	6.7 kW (400 V)	6.7 kW (400 V)	6.9 kW (400 V)
Alternative	5.7 kW (400 V)	2.2 kW (230 V)	–	5.4 kW (400 V)	2.6 kW (230 V)	2.6 kW (230 V)	4.9 kW (230 V)
Rated voltage	230/50/1 (400/50/3N)	400/50/3N (230/50/1)	400/50/3N –	230/50/1 (400/50/3N)	400/50/3N (230/50/1)	400/50/3N (230/50/1)	400/50/3N (230/50/1)
Width	436 mm	576 mm	635 mm	460 mm	600 mm	600 mm	635 mm
Depth	534 mm	604 mm	742 mm	590 mm	603 mm	640 mm	742 mm
Height	700 mm	820 mm	1,480 (1,960) mm	705 mm	825 mm	825 mm	1,510 (1,995) mm
Loading height	308 mm	360 mm	440 mm	315 mm	425 mm	425 mm	440 mm
Rack size	390x390 mm	500x500 mm	500x500 mm	400x400 mm	500x500 mm	500x500 mm	500x500 mm

\* The machine is equipped with an automatic cycle-time control which ensures hygienic rinse temperatures even on a cold-water supply or with reduced heating performance.



A registered brand of HOBART GmbH  
A company of the ITW Group

UNITED KINGDOM · HOBART UK  
Southgate Way · Orton Southgate · Peterborough I PE2 6GN  
Phone: +44(0)844 888 7777 · [customer.support@hobartuk.com](mailto:customer.support@hobartuk.com)  
[www.hobartuk.com](http://www.hobartuk.com)

[www.hobartindependent.co.uk](http://www.hobartindependent.co.uk)



The details given in this brochure are correct as of 10/2024.  
We reserve the right to technical or design modifications.

