

320L Refrigerators and Freezers

HW400

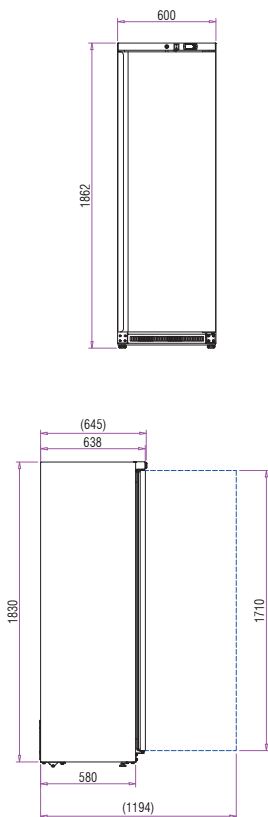

LS400



FEATURES

White laminated (W) or stainless steel exterior (S)

White aluminium interior

Reversible door

Lock fitted as standard

Refrigerator - 4 adjustable shelves
Freezer - 5 fixed shelves

Replaceable door gasket

TECHNICAL SPECIFICATIONS

	Refrigerator	Freezer
Controller:	Dixell controller	
Cooling:	Ventilated	Static
Defrost:	Automatic	Manual
Refrigerant:	R290	R290
Climate Class:	4	4
Temperature Range:	+2°C ~ +8°C	-18°C ~ -22°C
Power Supply:	13amp	13amp

MODEL	TEMPERATURE RANGE	GROSS CAPACITY	EXT. DIMENSIONS (H x W x D mm)	ENERGY RATING	POWER CONSUMPTION	KWH /ANNUM	DECIBELS	WEIGHT (kg)	RRP
HW400	+2°C ~ +8°C	320L	1862 x 600 x 645	E	267W	860	48dBA	100	£782.00
HS400	+2°C ~ +8°C	320L	1862 x 600 x 645	E	267W	860	48dBA	100	£854.00
LW400	-18°C ~ -22°C	320L	1862 x 600 x 645	-	350W	-	48dBA	108	£847.00
LS400	-18°C ~ -22°C	320L	1862 x 600 x 645	-	350W	-	48dBA	108	£931.00



600L Refrigerators and Freezers

HW600



LS600

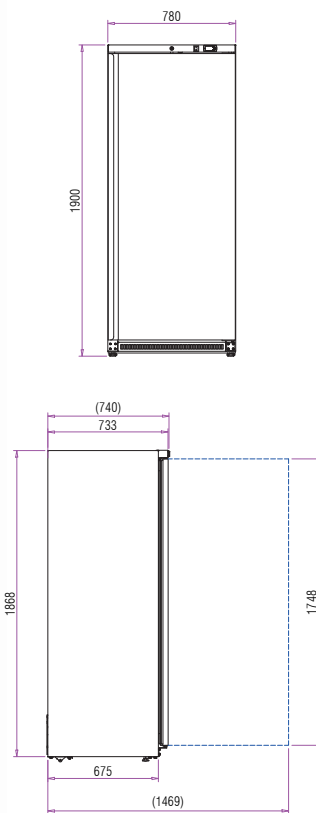

FEATURES

White laminated (W) or stainless steel exterior (S)

White aluminium interior

Reversible door

Lock fitted as standard

Refrigerator - 4 adjustable shelves
Freezer - 5 fixed shelves

Replaceable door gasket

TECHNICAL SPECIFICATIONS

	Refrigerator	Freezer
Controller:	Dixell controller	
Cooling:	Ventilated	Static
Defrost:	Automatic	Manual
Refrigerant:	R290	R290
Climate Class:	4	4
Temperature Range:	+2°C ~ +8°C	-18°C ~ -22°C
Power Supply:	13amp	13amp

MODEL	TEMPERATURE RANGE	GROSS CAPACITY	EXT. DIMENSIONS (H x W x D mm)	ENERGY RATING	POWER CONSUMPTION	KWH /ANNUM	DECIBELS	WEIGHT (kg)	RRP
HW600	+2°C ~ +8°C	600L	1900 x 780 x 740	D	267W	974	48dBA	110	£927.00
HS600	+2°C ~ +8°C	600L	1900 x 780 x 740	D	267W	974	48dBA	110	£1,009.00
LW600	-18°C ~ -22°C	600L	1900 x 780 x 740	-	350W	-	48dBA	120	£1,029.00
LS600	-18°C ~ -22°C	600L	1900 x 780 x 740	-	350W	-	48dBA	120	£1,100.00

