

Instruction Manual

Extraction Canopy Range

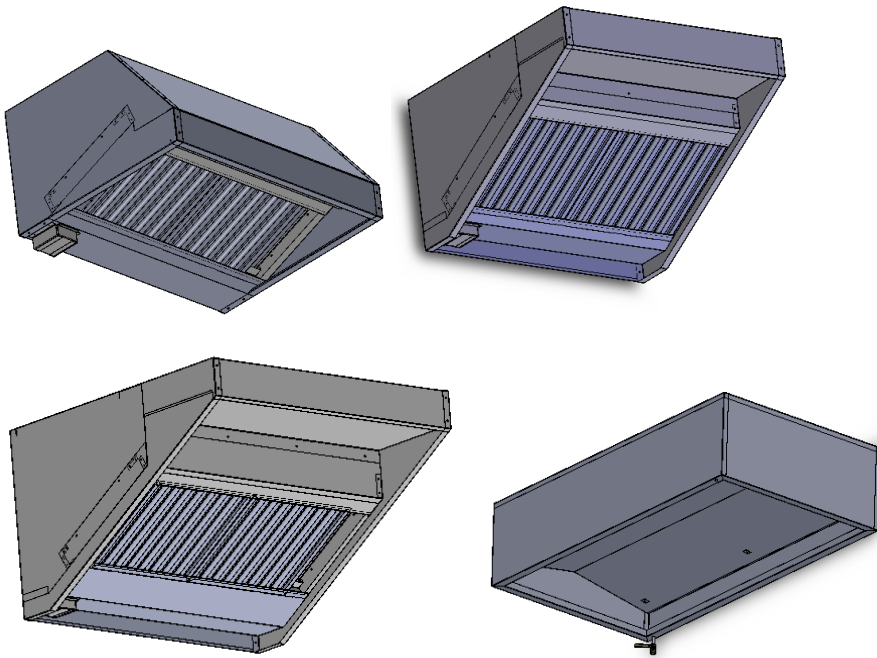

Available as:
Snack Type Range
General Type Range
Titan Type Range
Condensation Canopy Range

Built for purpose in Britain







Welcome to Parry...

We're proud to bring you quality stainless steel products that are designed for daily use – and built for purpose – right here in the UK.

When you work with us, you don't just benefit from our commitment to British craftsmanship. Our agile approach – combined with bespoke service – means that we're quickly able to adapt every aspect of our offering to fit your requirements.

-  With over 40 years' experience in commercial catering, our equipment heats quickly, cooks beautifully and cleans easily.
-  From food display units with specialist lighting to bespoke cupboard designs, our R&D team develop and refine products until they're precisely what you need.
-  Our extensive expertise and comprehensive support deliver benefits that go way beyond products leaving the factory.

If you have comments or questions, we'd be pleased to hear from you.

Contact us by calling **01332 875544** or visiting **www.parry.co.uk/contact-us**.



Contents





Contents	3
Product Overview	4
Safety Instructions	6
Installation Instructions.....	6
Cleaning Instructions.....	10
Fault Finding	11
Service Information.....	11
Wiring diagram	12
.....	13
Fixing Diagram	14
Parts List	15
Warranty Information	16
Disposal and Recycling	17



Product Overview

The Parry range of canopies has been designed to demystify the process of installing extraction above commercial catering equipment. The standard three designs of extraction canopy we offer can be purchase in packs with either internal fans or external fans. The packs include the associated flanges and speed controller to suit the fans spec for the length of canopy so you can rest assured that you have the key components needed to install the canopy.

The Parry canopy range benefits from :

-  Practical range of sizes to suit most kitchens
-  Good performance extraction fans
-  Quality stainless steel construction
-  Simple to specify kit of parts to suit most extraction requirements.
-  Parts warranty

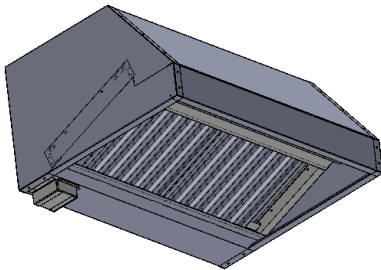

SNACK TYPE CANOPY	DETAIL
External Dimensions	1000/1200/1500/1800/2100/2400mm (w) x 810mm (d) x 500mm (h)
Removable drip tray	Yes
Fans packs available	Internal or external
Filters	All units provided with baffle filters
Construction	Stainless steel

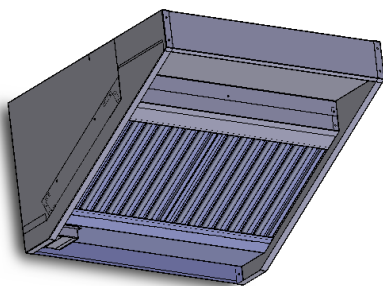

GENERAL TYPE CANOPY	DETAIL
External Dimensions	1000/1200/1500/1800/2100/2400mm (w) x 1000mm (d) x 600mm (h)
Removable drip tray	Yes
Fans packs available	Internal or external
Filters	All units provided with baffle filters
Construction	Stainless steel



Product Overview

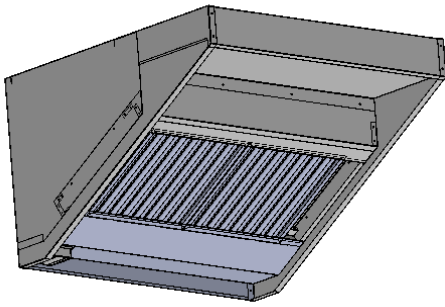

TITAN TYPE CANOPY	DETAIL
External Dimensions	1000/1200/1500/1800/2100/2400mm (w) x 1200mm (d) x 750mm (h)
Removable drip tray	Yes
Fans packs available	Internal or external
Filters	All units provided with baffle filters
Construction	Stainless steel

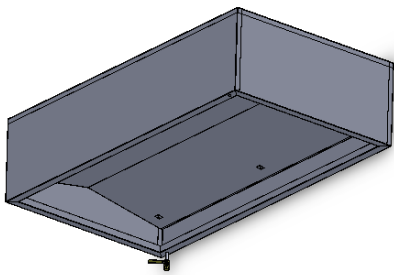





CONDENSATE CANOPY	DETAIL
External Dimensions	1000/1200/1700/2100mm (w) x 1100mm (d) x 500mm (h)
Integral drip tray	With drain tap
Fans packs available	No fan included
	All units provided with condensate plates
Construction	Stainless steel



Safety Instructions

Please read these instructions before you attempt to use the equipment. Keep these instructions for future reference.

-  To prevent shocks, the canopy, must be earthed.
-  To avoid scratching the highly polished exterior surface of this equipment whilst in transit, the protective film on the exterior surfaces has NOT been removed.
-  It is IMPORTANT that this protective film is peeled off before the equipment is used.
-  Ensure that vents intended to provide air flow in and around the unit are not obstructed.
-  Ensure the appliance is isolated from the power supply before installing, cleaning or maintaining the appliance



Installation Instructions

Specifying Instructions

Please consult HVCA Specification DW/172 and current local regulations, when specifying a canopy for a room.

Parry cannot specify extraction equipment or ducting due to the numerous factors that influence the selection of equipment for a certain environment.

Please ensure that you have checked that the canopy you select will have adequate air flow to extract the gases from the equipment that you propose to fit underneath it. If in doubt please seek professional advice.

All Parry canopies are manufactured from high quality stainless steel. The extraction canopy itself will be supplied with baffle filters and an easy to clean drip tray. Condensation canopies are fitted with a drain valve on one corner.

Installation Instructions

All gas appliances and gas interlock systems must be installed and commissioned by a registered gas safe fitter. Electrical products, and the wiring of lights and speed controllers must be fitted by an electrician. All ventilation ducting must be installed to comply with currents standards and building regulations.



Installation Instructions

Internal fan canopies

For canopies that have internal fans please ensure the fan is in the correct position before attempting to mount the canopy to a wall.

The centrifugal fan used within the internal fan packs draws air from both sides, so to work most effectively it has to be located centrally to give an even draw across the length of the canopy. In the longer lengths two fans may be required and these are spread equally a third of the way along the canopy length. Canopies with two fans require two sets of ducting, or a non return valve.

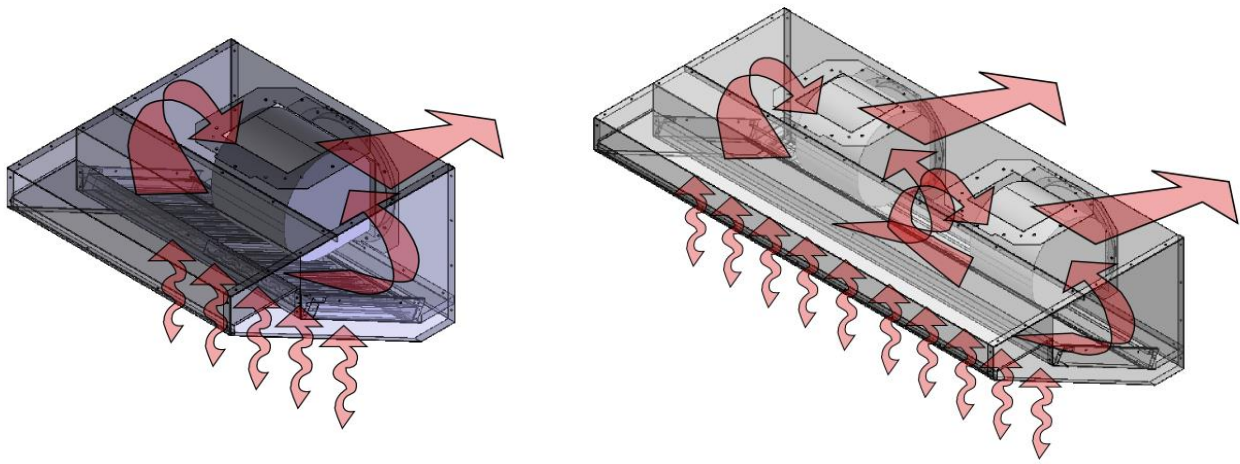

Repositioning the Internal Fan

As standard, canopies with internal fans will have the fan mounted to duct out of the centre back of the canopy as shown in figure 1. However if required the fan can be moved to duct out of the centre top of the canopy as shown in figure 2.

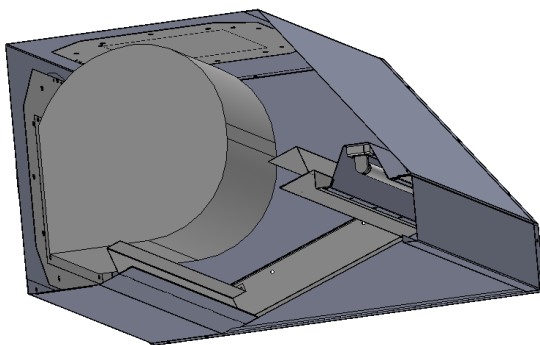

Figure 1

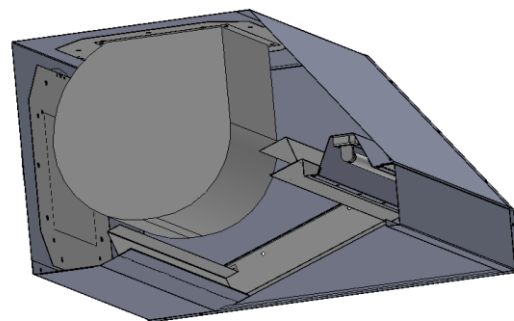

Figure 2

Please note that by removing the baffle filters and filter spacers by lifting and dropping them out of the channels you should be able to have just enough room to unbolt the fan and reposition it.



Installation Instructions

The fan is bolted to a plate with a square hole in it, using four pieces of threaded bar. The plate is then bolted to the canopy through the same holes as the flange.

To block off the holes in the canopy that are not being used, there is another plate, this time solid. It contains the same fixing holes as the fan plate, so can simply be bolted to the canopy in exactly the same way, making the two plates interchangeable.

If you do need to move the position of your fan please note that it will only fit in one way round. When located on the back, the flat side of the fan is facing downwards and when mounted on the top the flat side is facing forward as illustrated above.

Please ensure that all the bolts are securely tightened before hanging the canopy on the wall.

An earth tag has been provided and we would recommend that all units are earthed.

Information about the rating of the fan can be found on a label on the left inner side of the canopy. We would recommend you use this label to record the information relating to the canopy installation as it is commissioned.

External fan canopies

Parry offer all of their canopies with the option of an external fan packs. Especially useful for difficult applications, long runs and runs with a change in direction.

The external fan pack consists of a duct mount fan sized to the length of canopy, a pair of flanges, and a speed controller.

Canopies with external fans give the installer greater flexibility as to where the ducting can be mounted. Usually the installer would cut the hole in the canopy to suit where the ducting needs to be, however if stated with precise dimensions, holes can be cut into the canopy at the factory at an extra cost.

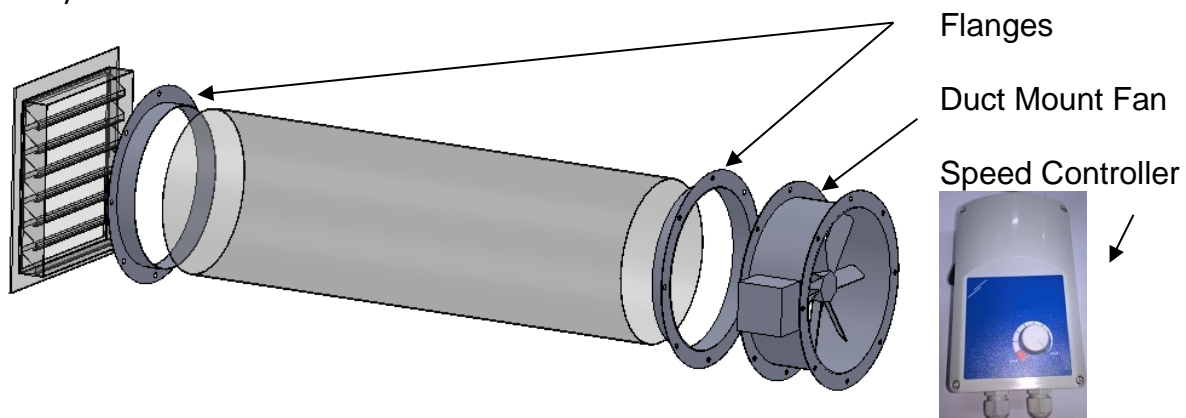



Installation Instructions

Parry does not supply any ducting and it is the responsibility of the installer to ensure that extraction ducting complies with all current standards. External weather louvered panels are not supplied as standard but can be bought separately from Parry. Parry can also supply reducers if you want to change the diameter of ducting leading away from the fan.

Hanging the canopy on a wall

The method chosen to hang the canopy to a wall or ceiling will depend greatly on the type and material of the wall or ceiling. It is the responsibility of the installer to check the structure is strong enough for the weight of the canopy and to use appropriate fixings.







If a canopy has been supplied on a stand or mounted to a table it may still need to be tied to a wall or ceiling for rigidity.

1. Choose a suitable position for your unit taking into consideration ducting, the location of units underneath it, and current standards. Do not butt the unit up against another unit which will get hot. Do not let the position of the unit blank off any ventilation vents on any other adjacent units.
2. Remove all protective film and packing material.
3. Holes can be drilled through the back or top of the canopy to screw directly to a wall or ceiling. In some circumstances it may be beneficial to run a baton along the wall for the unit to sit onto, as well as screwing directly into the wall.
4. If in the case of a condensate canopy the unit may be suspended from the ceiling with chain. Take steps to prevent the canopy from swaying, which could happen as doors into the room are opened and closed.
5. Please note that on canopies a fat collection tray may be situated to one side of the unit, and on condensate canopies a drain valve is located in one corner. To help the liquid flow into the drain or tray, it is best to fix the unit at a slight angle.



Cleaning Instructions

The appliance should be cleaned after every use and drip trays emptied as and when they fill up.

-  Allow canopy and any equipment sited below, to cool down before draining or cleaning the canopy
-  Turn off the mains power.
-  Remove baffle filters and clean in hot soapy water.
-  Wipe down the channel that the baffle filters sit in with soapy water.
-  If the canopy contains an internal fan this must be cleaned regularly to avoid grease build up on the fan blades that will cause the fan to become inefficient and noisy.
-  Stainless steel cleaners maybe used on the canopy but cleaning instructions on the product must be adhered to.
-  Never clean the unit with water jets.



Maintenance Instructions

Ensure the appliance is isolated from the power supply before installing, cleaning or maintaining the appliance.



Fault Finding

Fault	Check	Solution
Canopy not extracting	The unit has been installed by a professional and is connected to the mains	Turn on mains power
	Canopy is the correct size for the equipment that has been sited below it	Seek professional advice or see DW/172 Guidelines
Fan extraction is not very strong	Check the setting of the speed controller	Adjust if necessary
	Check that the fan is clean and that a build up of grease on the fan blades is not preventing them from turning efficiently	Clean fan
	Ensure there is nothing blocking the filters or ducting	Remove blockage
	Fan positioned incorrectly	Move fan to correct position
	Fan not wired correctly	Wire fan in accordance with the wiring guide provided
Fan is noisy	Check that the fan is clean and that a build up of grease on the fan blades is not preventing them from turning efficiently	Clean fan



Service Information

This appliance should be routinely serviced to prolong its lifetime. Parry recommends that the appliance is serviced every 12 months by a Parry authorised engineer. Failure to service your product within the initial 12 month warranty period will cause the 24 month warranty to become void.

If the supply cord becomes damaged, it must be replaced by the manufacturer, it's service agent, or a similarly qualified person.



Wiring Diagram

Speed Controller Instructions

For models CONTRE3-A and CONTRE6-A

Technical Data

Code	Current Range	Fuse
CONTRE3-A (STL-0-30-AT)	0.1-3.0A	5.0A
CONTRE6-A (STL-0-60-AT)	0.5-6.0A	10.0A

Enclosure: Plastic R-ABS, UL94-VO, grey RAL 7035, IP54

Max ambient temperature: 35degrees centigrade

For indoor use only, non-condensing



The electronic speed controller of these series control the speed of single phase (230 VAC – 50 HZ) voltage controllable motors by varying the supplied voltage through phase angle control. There is a potentiometer and a separate ON/OFF switch with built in tell tale, The minimum speed allowed can be adjusted internally with a little trimmer (Factory pre-set = 100V). The terminal board has a supplementary connection to bypass the ON/OFF switch (automatic start) or to branch off 230V not controlled (three wire motor connection, valve, lamp, damper, etc...)

There are two working modes internally selectable by placing or removing the red jumper on the PCB (See illustration)

Kickstart : the motor will always start (or reset) at max speed for 8 seconds, after that the motor speed automatically follows the position of the potentiometer.

Normal start : the motor starts according to the position of the potentiometer.

1. Be sure that the controller is in the OFF position.
2. Take off the box cover by loosening the 4 screws. Note that the potentiometer is connected to the PCB with 2 wires.
3. Connect mains, motor(s) and earth cables of the proper diameter to the terminals according to the scheme below.
4. Start the controller and adjust the little trimmer so that the motor continues turning or restarts smoothly in case of power faults. The minimum speed is factory preset at 100V
5. Close the box and verify that the installation works fine.
6. The operating position must be shown below.

Connections

LN	Mains supply 230Vac-50Hz
N	neutral
Pe	earth connection
L1N	230Vac not regulated output for connecting lamp, valve, dampers ... or three wire motor connections; branched off after switch and fuse Input: to bypass switch and fuse (ATTENTION)
N	regulated output to motor
Jumper	Jumper removed = normal working mode Jumper in place = kickstart working mode
Trimmer	minimum speed adjustment trimmer



Wiring Diagram

CONTRE3-A (STL-0-30-AT)



CONTRE6-A (STL-0-60-AT)



1. Kick start selection jumper JP1		Kick start is enabled
		Kick start disabled (normal start)
2. Minimum speed trimmer PT1		Adjusts the min. speed (factory preset 100 VAC)

Single phase wiring diagram for both comodels

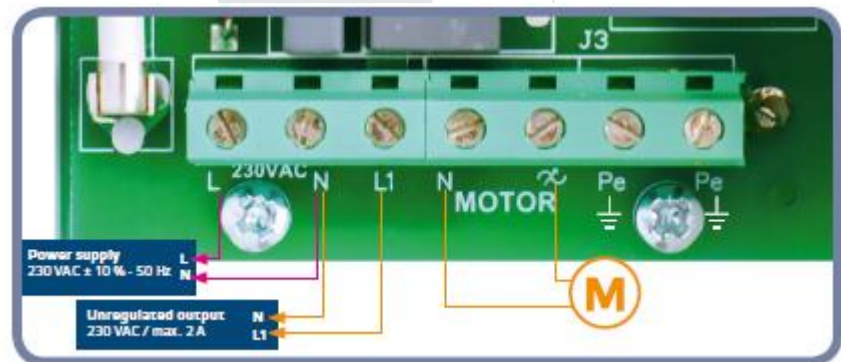



Fixing Diagram

Code	A	B	C	D	E	F
CONTRE3-A (STL-0-30-AT)	162mm	96mm	75mm	71mm	108.8mm	4.2
CONTRE6-A (STL-0-60-AT)	205mm	124mm	97mm	102mm	140mm	46

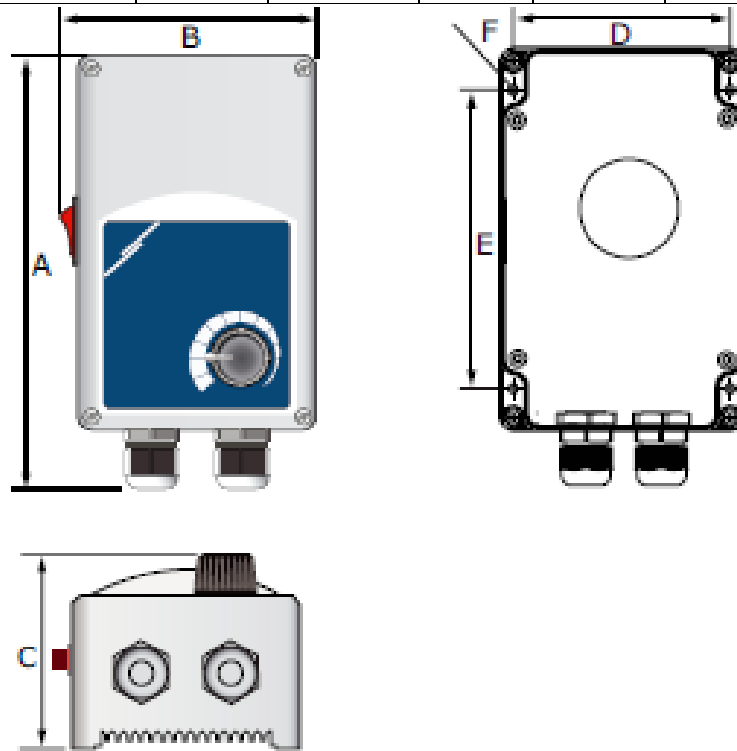



Parts List

Part Number	Description	Code
Internal Fan Pack (IF) for use with all sizes of canopy		
	Snail fan supplied with square mounting plate	FANBD9-9
	6amp speed controller	CONTRE6-A
	Set of two 400mm round flanges	FLANGE8897
External Fan Pack (EF) for use with canopies 1000/1200/1500/1800mm		
	400mm round duct mount fan	FANZSC400
	3amp speed controller	CONTRE3-A
	Set of two 400mm round flanges	FLANGE8897
External Fan Pack (EF) for use with canopies 2100/2400mm		
	450mm round duct mount fan	FANZSC450
	6amp speed controller	CONTRE6-A
	Set of two 450mm round flanges	FLANGE8898



Warranty Information

The manufacturer's warranty is only valid in the UK mainland. Northern Ireland, Western Isles, Inner Hebrides and Islands are parts only warranty. Please be aware that the warranty starts from the date of purchase from Parry and not the sale or installation date of the equipment.

To be eligible for a 2 year warranty, products must be serviced at least once within the first 12 months of purchase.

All service calls will be carried out between 8am and 5pm, Monday to Friday.

Your warranty is invalid if your equipment has not been installed in accordance with the manufacturer's instructions. The misuse, alteration or unauthorised repairs of the equipment will also invalidate the warranty.

During the warranty period it is at Parry's discretion whether to repair or replace the equipment. The warranty only applies if the equipment has been used in a professional manner following the manufacturer's instructions and maintenance guidelines.

The warranty covers defects in the material and component failure only. We are not liable for trading loss, loss of perishable items, water damage or loss due to injury or fire damage.

Please ensure you have referred to the manufacturer's instruction before placing a warranty call.

Contact our warranty department on **01332 875544** for technical assistance.

Please have your model number ready before calling.







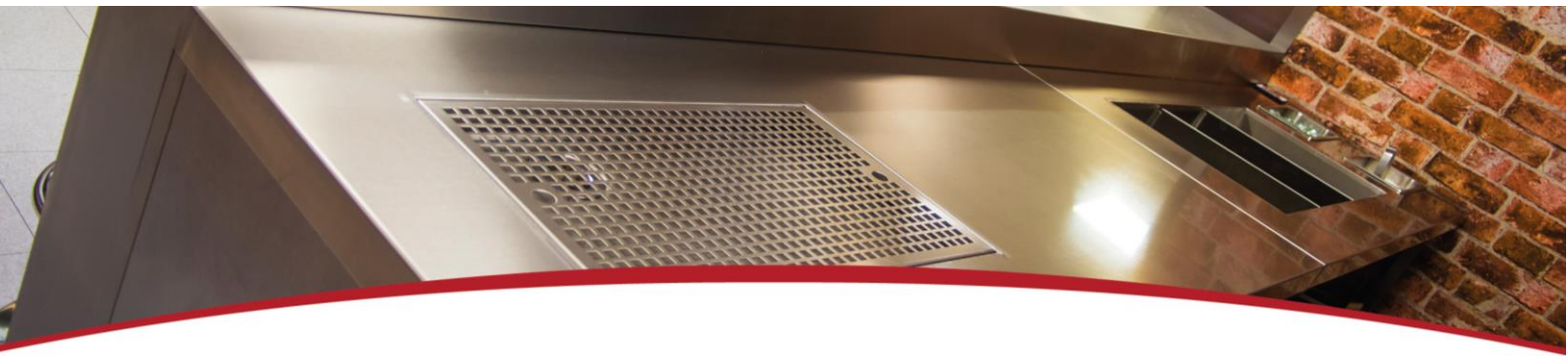





All warranty requests must be submitted to warranty@parry.co.uk.

Failure to pay any warranty charges will result in your warranty being put on hold until the bill has been settled. Any issues regarding the raised charges should be put in writing to our warranty department for further investigation.

Register your product by visiting our website www.parry.co.uk



Not covered under warranty

-  Fault due to incorrect installation, poor maintenance or equipment abuse.
-  Resetting of equipment or circuit breakers.
-  Faulty electrics – e.g. customer's plug socket, plug, wiring, junction box fault, wrong fuse.
-  Products must be serviced within the first 12 months to be eligible for the 2 year warranty
-  Product not covered by warranty if combustible materials have been used, e.g. plastic trays.
-  Foil used on racks, blockages and lime scale issues.
-  Failure to grant access for pre-arranged service call.
-  Equipment that has been set up or used incorrectly e.g. dishwasher detergents, levelling and setting up of doors on a six burner cooker.
-  Excessive carbon build-up on griddle plates or overuse of lava rock on chargrills. (Recommended use by Parry no more than 2kg.)
-  Appliances that have been installed in mobile trailers are covered by parts only warranty for 24 months.
-  Extraction canopies are sold with parts only warranty on the fans and speed controllers for 24 months. If parts are found to be faulty through lack of cleaning of the extraction canopy the part will be chargeable. The equipment should be installed by a competent person. The equipment installer needs to know the design, performance and the capacity of the ventilation system, so they can ensure adequate ventilation.
-  All of the above points are not covered by warranty and any costs incurred, because of the above, will be forwarded to the parties responsible for placing the call.



Disposal and Recycling

This appliance is marked according to the European Directive 2002/96/EC on Waste Electrical and Electronic Equipment (WEEE).

By ensuring this product is disposed of correctly, you will help prevent potential negative consequences for the environment and human health which could otherwise be caused by inappropriate waste handling of this product.

A symbol on the product, or on the documents accompanying the product, indicates that this appliance may not be treated as household waste. Instead it should be handed over to the applicable collection point for the recycling of electrical and electronic equipment.



Disposal must be carried out in accordance with local environmental regulations for waste disposal.

For more detailed information about treatment, recovery and recycling of this product, please contact your local city office, your household waste disposal service or the shop where you purchased the product.

Parry Catering recognises our obligations to the EU DIRECTIVE covering the waste disposal of electrical and electronic equipment (WEEE) Parry Catering are committed to this policy in order to help conserve the environment.

At the end of this units life you **MUST** dispose of it in an approved manner. You **MUST** not discard the unit or place it in the refuse bin.

You have several options:



Take the unit to an approved WEEE scheme company, there will be one in your area.



Take the unit to an approved waste disposal site; many sites are managed by your local authority.



Contact the units manufacturer, importer or their agent; the contact details will be on the unit.

There will probably be a charge for this service which will depend on the physical size and location of the unit. You will be given a collection price for a curb side collection based on commercial rates prevailing at the time.

It should be noted that the unit to be collected should be suitably packed and sealed to prevent dangerous gases and fluids from escaping. The condition of the unit must also be clean to comply with health and safety regulations.