

Stainless Steel Lid Chest Freezers

SZ362STS

**STAINLESS
STEEL LID**

SZ464STS

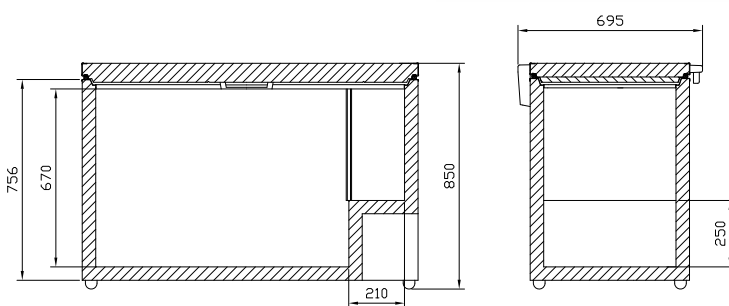

FEATURES

- Anti-corrosion painted plate exterior in grey
- Aluminium interior
- Stainless steel lid with plastic capped ends
- Lock as standard
- Internal illumination
- Depth - including handle 695mm
- Drain and drip tray supplied
- Skin condenser
- Fast freeze function

TECHNICAL SPECIFICATIONS

Controller:	Manual thermostat with digital temperature display
Cooling:	Static
Defrost:	Manual
Refrigerant:	R600a
Climate Class:	SN-T
Temperature Range:	-18°C ~ -22°C
Power Supply:	13amp

MODEL	GROSS CAPACITY	BASKETS SUPPLIED	MAX. BASKETS	EXT. DIMENSIONS (H x W x D mm)	POWER CONSUMPTION	DECIBELS	WEIGHT (kg)	RRP
SZ362STS	370L	2	12	850 x 1260 x 695	145W	36dBA	65	
SZ464STS	475L	2	15	850 x 1560 x 695	190W	37dBA	75	

