



WATER



GAS



ENVIRONMENT



PEST CONTROL

INTRODUCING...

HYGENIKX+

The ultimate air and surface hygiene amplifier

PROVEN TO REDUCE FOOD SPOilage

REDUCE FOOD WASTE & COST

IMPROVE HOSPITALITY HYGIENE AND SAFETY

KILLS SALMONELLA, E.COLI, NOROVIRUS and other primary sources of infections

TARGET & ELIMINATE HARMFUL BACTERIA

HyGenikx is an advanced and compact, wall mounted hygiene amplification system, proven to eradicate bacteria and viruses throughout the food service & hospitality environment, washrooms, changing rooms and beyond, in terms of applications.

Utilising a combination of the most effective air and surface sterilisation technologies available, HyGenikx provides round-the-clock hygiene and safety protection, controls odours and has also significantly been proven to prolong the life of fresh perishable foods.



WATER



GAS



ENVIRONMENT



PEST CONTROL

THE ULTIMATE AIR & SURFACE HYGIENE AMPLIFIER

HYGENIKX+

The HyGenikx range features and benefits:

- **Kills Escherichia coli (E. coli), Staphylococcus aureus (S. aureus), Clostridium difficile (C. difficile), Aspergillus fumigatus,** and other primary sources of infections
- **Significantly improves hygiene standards** to levels impossible to maintain with traditional cleaning methods alone
- **Eliminates bacteria, viruses, moulds, fungi and volatile organic compounds (VOCs),** both in the air and on exposed surfaces, even in the hardest to reach places
- **Safe to use and for the environment**
- **Eradicates unpleasant odours** by tackling them at source
- Proven to **deplete harmful Listeria monocytogenes and Listeria innocua** from surfaces to undetectable levels
- **Improves infection control for staff and customers**
- Proven to **reduce spoilage** by **extending the shelf-life of perishable food** on average by 58%, and up to 150% for certain produce**
- **Low energy consumption,** only 85 watt
- Easy to change lamp and backup battery, **requires no onsite engineer**
- Power via a plug that allows flexible installation and **easy connection to existing sockets or to switched spurs**
- Available in **white or titanium** finish
- **Models to suit various applications,** including front of house, washrooms, food prep areas, cold rooms, refuse areas and beyond (see model reference chart)

**Validation of a HyGenikx air purification unit as an aid to prolong the shelf-life of refrigerated fresh foodstuff and to improve environmental conditions. ALS Life Sciences Europe



MODEL REFERENCE CHART

	GENERAL*		FOOD*†		REFUSE*	
	WHITE finish	TITANIUM finish	WHITE finish	TITANIUM finish	WHITE finish	TITANIUM finish
10m ²	HGX-W-10-S	HGX-T-10-S	HGX-W-10-F	HGX-T-10-F	×	×
20m ²	HGX-W-20-S	HGX-T-20-S	HGX-W-20-F	HGX-T-20-F	×	×
30m ²	HGX-W-30-S	HGX-T-30-S	HGX-W-30-F	HGX-T-30-F	×	×
NON-OCCUPIED	×	×	×	×	HGX-W-15-R	HGX-T-15-R

* GENERAL: for use in areas such as washrooms, front of house and changing areas / FOOD: for use in areas such as cold rooms and food prep areas / REFUSE: NOT for use in areas of continuous occupation.

† FOOD area models are supplied with food safe shatter-proof lamps.

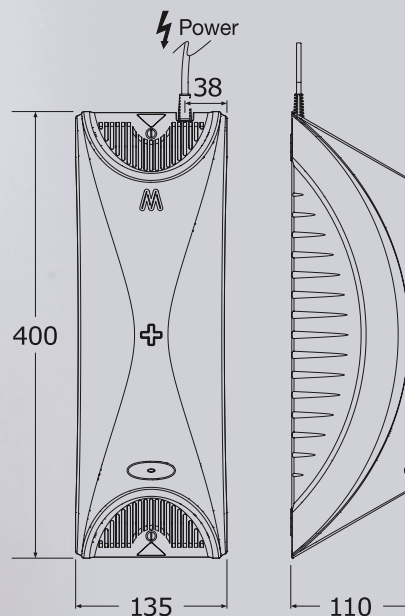

SPECIFICATION

- Combines technologies: Germicidal Oxidation, Germicidal Irradiation, Dual waveband Plasma Quattro.
- Services: 240/50/1. Uninterrupted supply – 24 hour operation required. High level.
- Dimensions: 400 x 135 x 110mm
- EC declaration of conformity
- CE mark
- Low voltage directive 2014/35/EU
- EN 60335-1:2012 +A13:2017
- EN 60335-2-59:2003 +A1:2006 +A2:2009
- EN 62233:2008
- Class 1 certified for electrical insulation
- Designed and manufactured to EUOTA (European Ozone Trade Association) requirements