

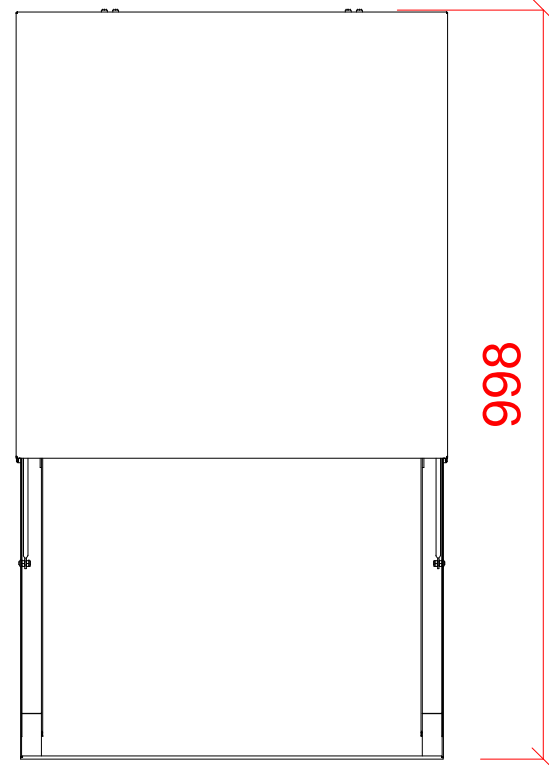

Undercounter Dishwasher

F504-20B

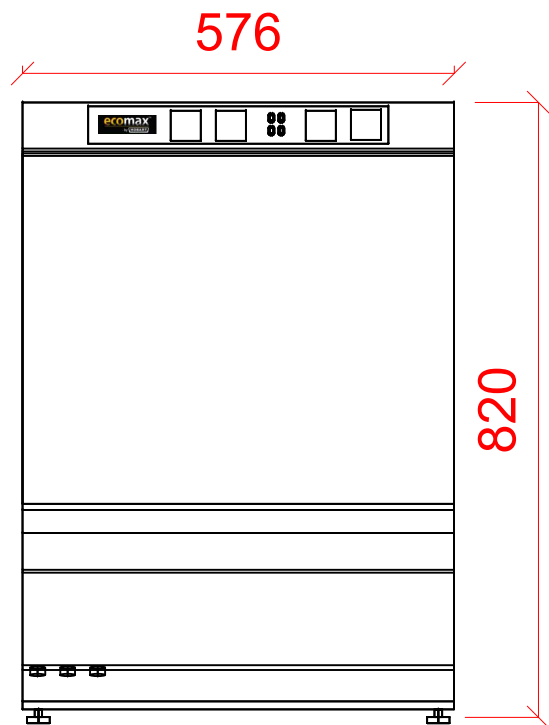
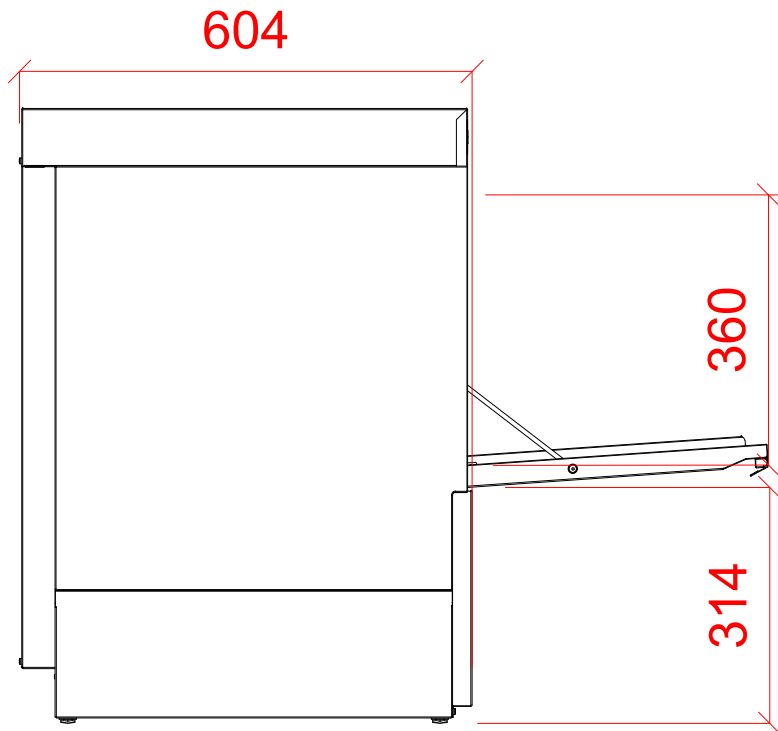

|   |   |  |
|---|---|--|
| <p><b>1</b> Water</p> <p>22mm CONNECTION VIA 2 METRE FLEXIBLE HOSE, FEMALE TERMINATION.</p> <p>WATER SUPPLY 15°C TO 65°C @ 0.8 TO 6.0 BAR MAX.<br/>INITIAL TANK FILL 25 LITRES.<br/>RINSE WATER USAGE 2.3 LITRES PER CYCLE. MAX USAGE 138 LITRES PER HOUR.<br/>OUR MACHINES ARE SUPPLIED WITH CLASS 'AA' AIR GAP AS STANDARD.</p> | <p><b>2</b> Drain</p> <p>DRAIN: 2.0 METRE FLEXIBLE HOSE TO A 40mm TRAPPED STANDPIPE<br/>650mm MAX A.F.F.L.</p> <p>FLOW RATE 30 LITRES PER MINUTE.</p> | <p><b>3</b> Electric</p> <p>4.1kW 230/50/1 FUSED AT: 1 x 25amps.<br/>CONFIGURABLE TO:<br/>5.9kW 400/50/3 FUSED AT: 3 x 16amps<br/>2.2kW 230/50/1 FUSED AT: 1 x 13 amps<br/>MACHINE SUPPLIED WITH 2.0 METRES OF CABLE</p> |
| <p><b>Other Services</b></p> <p>RINSE AGENT HOSE - 2.5 METRE FLEXIBLE.<br/>DETERGENT HOSE - 2.5 METRE FLEXIBLE.</p>   |   | <p><b>Notes</b></p> <p><b>+40mm</b> ADJUSTMENT FOR FEET<br/>NET WEIGHT 46kg.</p>   |

PLOT SCALE: 1:10

RIGHT TO MAKE NECESSARY CHANGES IS RESERVED